



GSZ-4/6 - SERIES
 [4Pole]HIGH VOLUME - DEWATERING PUMP
 [6Pole]HIGH VOLUME - SAND PUMP & AGITATOR PUMP

SPECIFICATIONS

FEATURES

1. Enclosed, high chrome cast iron or Stainless Steel impeller with field adjustable/replaceable wear plate provides for high wear resistance when the pumpage contains abrasive particles.
2. Highly efficient, continuous duty air filled, copper wound motor with class F, E, insulation minimizes the cost of operation.
3. Built in thermal protection prevents motor failure due to overloading, accidental run-dry and single phasing in three phase units.
4. Double inside mechanical seals with silicon carbide faces, running in an oil filled chamber, further protected by a labyrinth seal, running against a replaceable, 430 stainless steel shaft sleeve and seal pressure relief ports,-

Providing for the most durable seal design available.

5. Double shielded, permanently lubricated, high temperature C3 ball bearings rated for a B-10 life of 60,000 hours provide for extended operational life.
6. The agitator installed on the motor shaft extension forcibly agitates the fluid for easy and efficient transmission of sludge and slime. (GSZ5-37-6SK)

APPLICATIONS

1. Commercial, industrial wastewater and construction site drainage.
2. Sand & Gravel pit drainage.
3. Sediment removal from sumps or basins.



SPECIFICATIONS

- Discharge Size
- Horsepower Range
- Performance Range Capacity Head
- Maximum water temperature
- Materials of Construction
 - Casing
 - Impeller
 - Shaft
 - Motor Frame
 - Fasteners
- Seal Pressure Relief ports
- Mechanical Seal
 - Elastomers
- Impeller Type
- Solids Handling Capability
- Bearings
- Motor Nomenclature
 - Type, Speed, Hz.
 - Voltage, Phase
 - Insulation
- Accessories
- Operational Mode

STANDARD

- 6"~10" NPT (150mm ~ 250 mm)
- 30 HP.~ 100 HP. (22 kW ~ 75 kW)
- 528 ~ 4621 GPM (2.0 ~17.5 m³/min)
- 24.6 Ft. ~ 197.0 Ft. (7.5 m ~ 60.0 m)
- 104°F. (40°C.)
- Cast Iron
- High Chrome Iron/Stainless Steel
- 420 Stainless Steel
- Cast Iron/Steel Jacket
- 304 Stainless Steel
- 4P-1800RPM Motor Model
- Silicon Carbide
- NBR (Nitrile Butadiene Rubber)
- Enclosed, Open, solids handling
- 0.394 ~ 1.97" (10 - 50mm)
- Prelubricated, Double Shielded
- Air Filled, 1200 & 1800 Rpm, 60 Hz.
- 460 or 575 V., 3 Phase
- Class F or E
- Submersible Power Cable 50' (15 m)
- Manual

OPTIONS

Length as Required.



TSURUMI PUMP

GSZ - SERIES

[4 Pole] High Volume - Dewatering Pumps
[6 Pole] High Volume - Sand Pumps & Agitator Pump

PERFORMANCE RANGE

GROUP PERFORMANCE RANGE

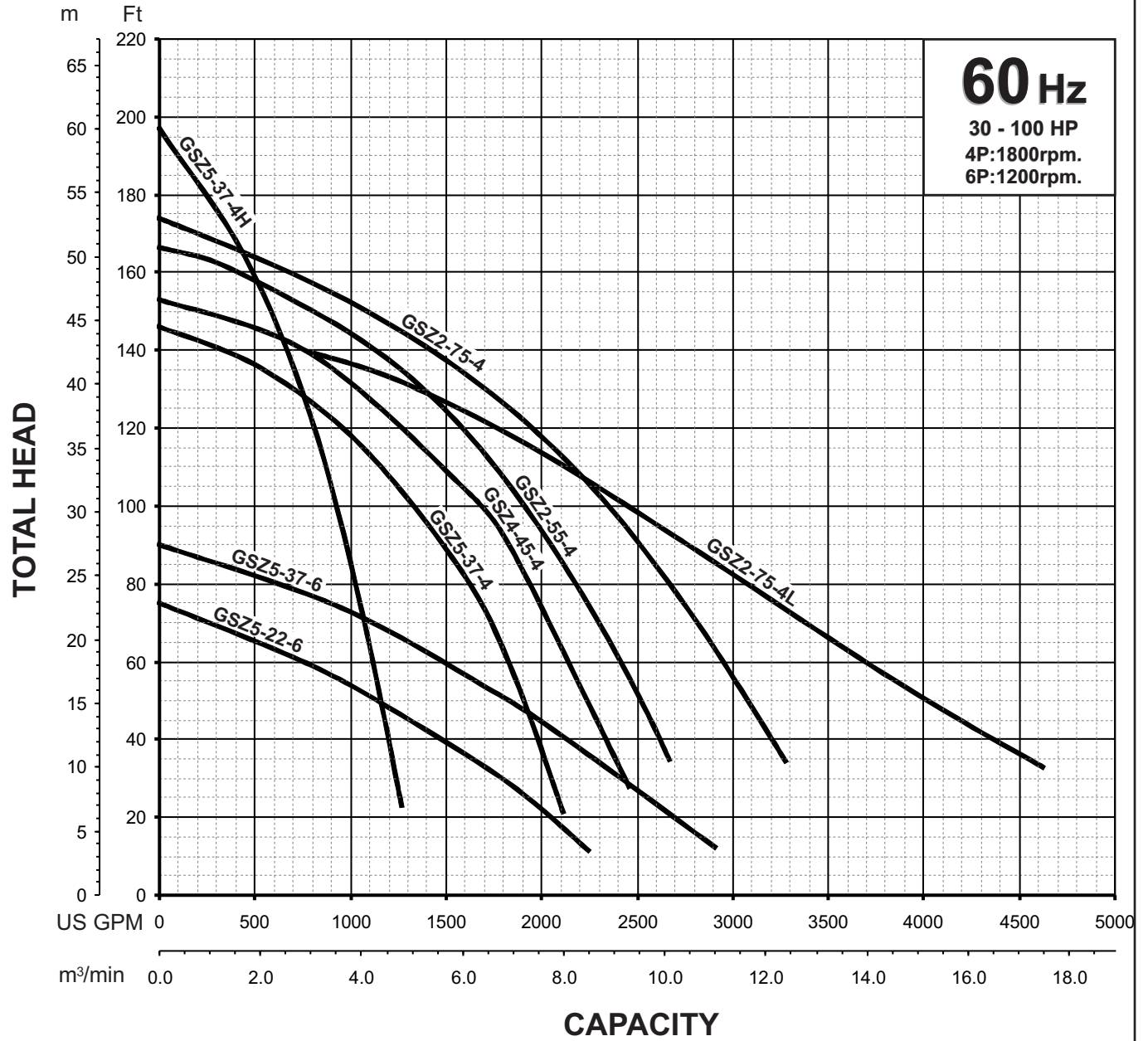



GSZ-4 SERIES HIGH VOLUME - DEWATERING PUMPS

PERFORMANCE CURVE

MODEL		BORE	HP	KW	RPM	SOLIDS DIA	LIQUID	SG.	VISCOSITY	TEMP.
GSZ2-55-4		10"/250mm	75	55	1775	0.984"/25mm	Water	1.0	1.123 cSt.	60°F
PUMP TYPE		PHASE	VOLTAGE		AMPERAGE		HZ	STARTING METHOD		INS. CLASS
High Volume - Dewatering Pump		3	460 / 575		97 / 76		60	Star-Delta		E
CURVE No.	DATE	PHASE	VOLTAGE	AMPERAGE	HZ	STARTING METHOD	INS. CLASS			
-	-	-	-	-	-	-	-			

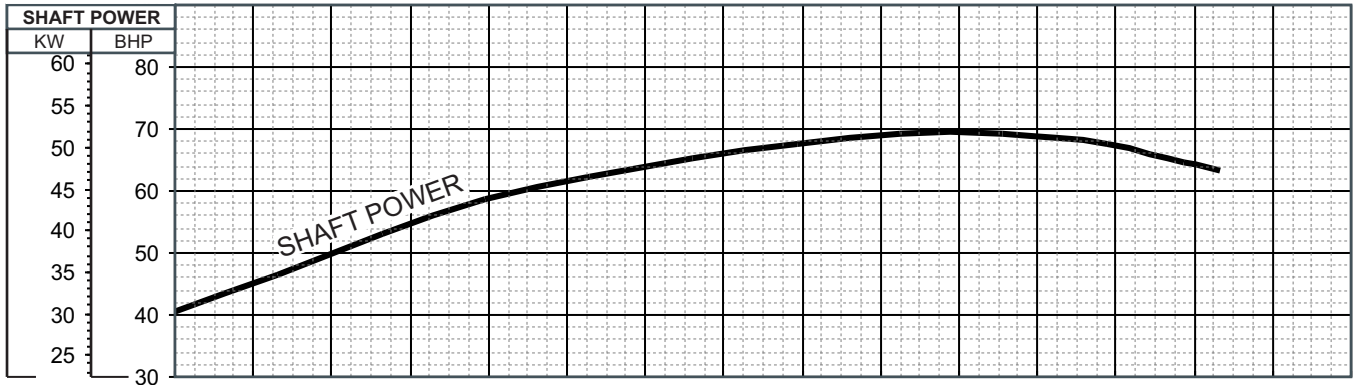
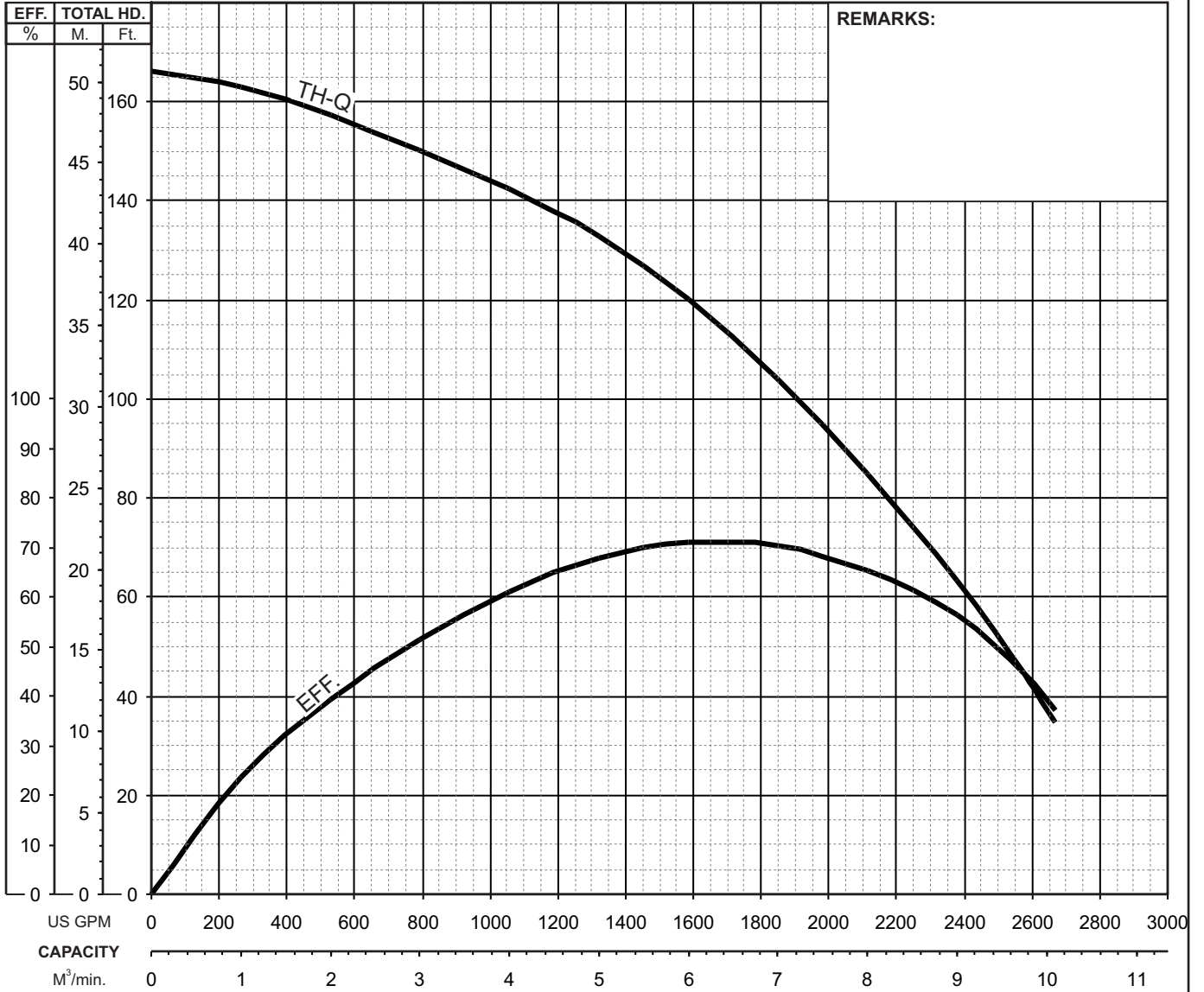



GSZ-4 SERIES
HIGH VOLUME - DEWATERING PUMPS

DIMENSIONS

GSZ2-55-4
GSZ2-75-4

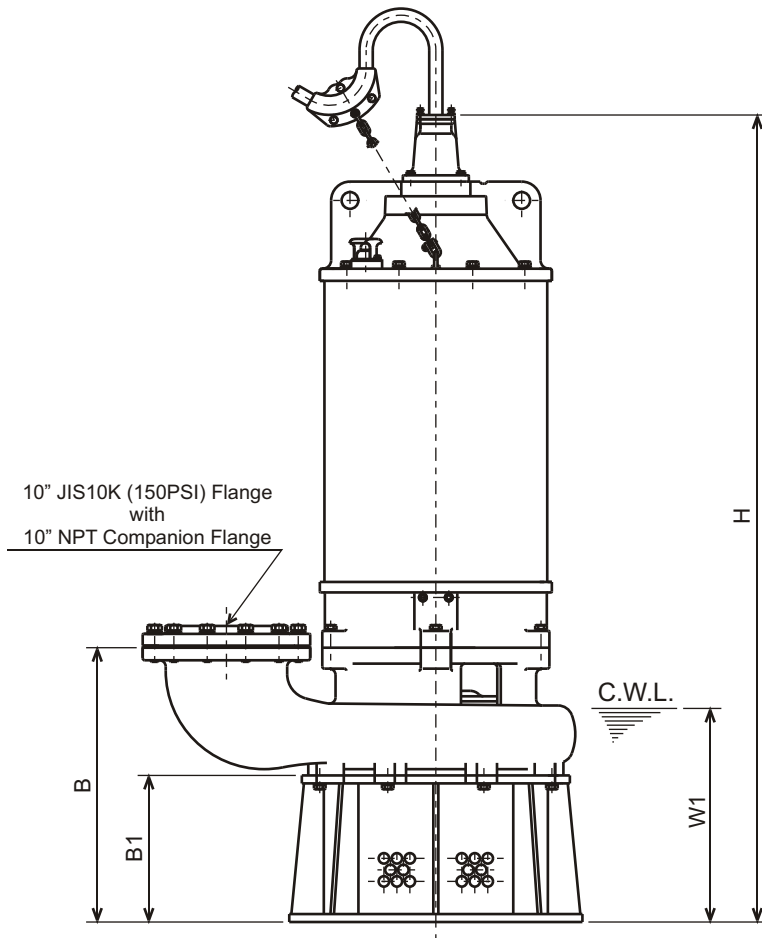
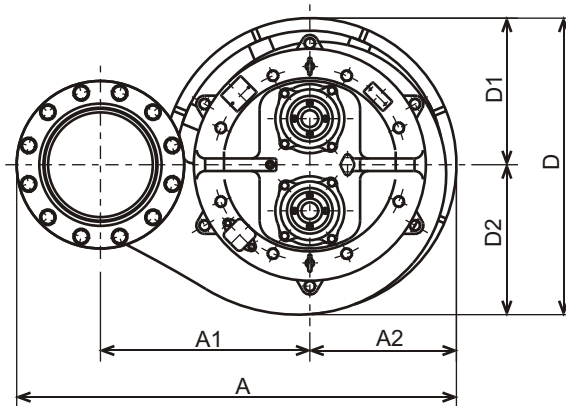

C.W.L. : Continuous running Water Level

DIMENSIONS:USCS (In ch)

Model	HP	NOM. SIZE	Pump & Motor									C.W.L. W1	*Wt. (lbs.)
			A	A1	A2	B	B1	D	D1	D2	H		
GSZ2-55-4	75	10"	41 5/16	19 11/16	13 3/4	25 13/16	13 3/4	27 7/8	13 3/4	14 1/8	75 7/8	20 1/8	2430
GSZ2-75-4	100	10"	41 5/16	19 11/16	13 3/4	25 13/16	13 3/4	27 7/8	13 3/4	14 1/8	75 7/8	20 1/8	2680

DIMENSIONS:METRIC (mm)

Model	kW	NOM. SIZE	Pump & Motor									C.W.L. W1	*Wt. (kg)
			A	A1	A2	B	B1	D	D1	D2	H		
GSZ2-55-4	55	250	1050	500	350	655	350	708	350	358	1927	510	1105
GSZ2-75-4	75	250	1050	500	350	655	350	708	350	358	1927	510	1215

*Excluding Cable



GSZ-4 SERIES
HIGH VOLUME - DEWATERING PUMP

SECTIONAL VIEW

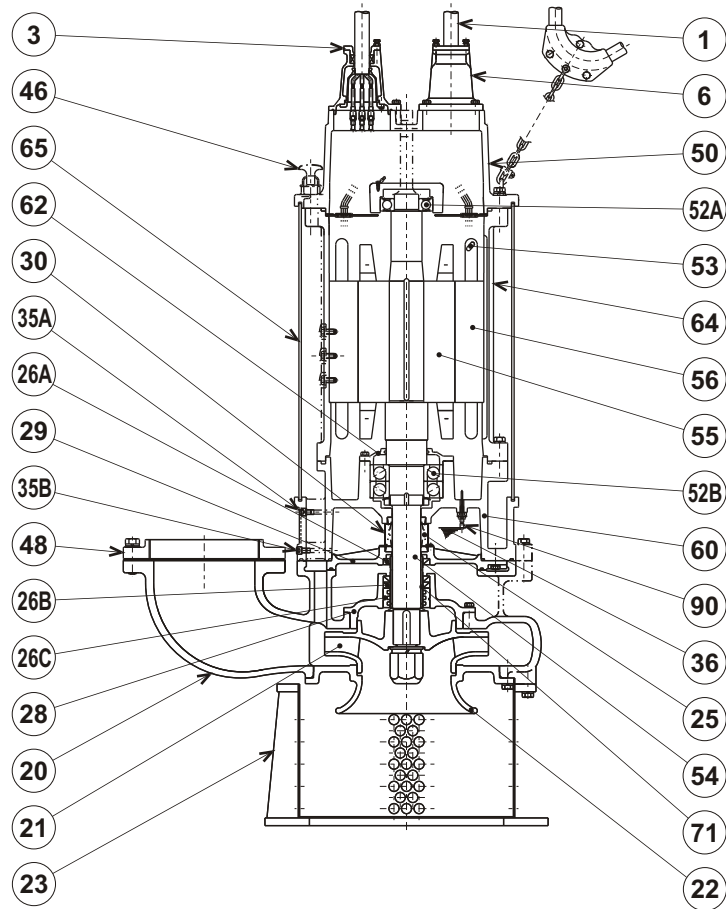

GSZ2-55-4
GSZ2-75-4

ITEM#	DESCRIPTION	MAIN MATERIAL / NOTE	ASTM, AISI CODE	RELATED EN CODE	Q'TY
1	Power Cable	Chloroprene Sheath AWG 2/3 , 6/1 , 14/3 -50ft			1
	Power Cable	Chloroprene Sheath AWG 2/3 -50ft			1
3	Gland	Cast Iron	A48M Class30B	EN 1561 GJL-200	2
6	Stuffing Box	Cast Iron	A48M Class30B	EN 1561 GJL-200	2
20	Pump Casing	Cast Iron	A48M Class30B	EN 1561 GJL-200	1
21	Impeller (GSZ2-55-4)	High Chrome Cast Iron	A532 Class TypeA	DIN 1695 G-X260Cr27	1
	Impeller (GSZ2-75-4)	Stainless Steel Casting	A743 CF-8	GX5CrNi19-10	1
22	Suction Cover	Cast Iron	A48M Class30B	EN 1561 GJL-200	1
23	Suction Strainer	Steel	A283 Grade D	EN 10025 S275	1
25	Mechanical Seal	Silicon Carbide / H-70			1
26A	Oil Seal	NBR / TC-8011515			2
26B	Oil Seal	NBR / TC-8011515			1
26C	Labyrinth Ring	Stainless Steel	S 40300	1.4000	1
28	Seal Housing	Cast Iron	A48M Class30B	EN 1561 GJL-200	1
29	Oil Casing	Cast Iron	A48M Class30B	EN 1561 GJL-200	1
30	Oil Lifter	Steel (Cold Rolled)	A109/A1008	EN 10130	1
35A	Oil Plug	Stainless Steel	S 30400	1.4301	2
35B	Oil Plug	Stainless Steel	S 30401	2.4301	1
36	Lubricant	Turbine Oil ISO VG32 or SAE 10W-20			
46	Air Release Valve	Steel (Cold Rolled)	A109/A1008	EN 10130	1
48	Companion Flange	Cast Iron / NPT 10" JIS10K	A48M Class30B	EN 1561 GJL-200	1
50	Motor Bracket	Cast Iron	A48M Class30B	EN 1561 GJL-200	1
52A	Upper Bearing	#6312ZZC3			1
52B	Lower Bearing	#7317BDB			1
53	Motor Protector				3
54	Shaft	Stainless Steel	S 42000	1.4028	1
55	Rotor				1
56	Stator				1
60	Bearing Housing	Cast Iron	A48M Class30B	EN 1561 GJL-200	1
62	Bearing Cover	Cast Iron	A48M Class30B	EN 1561 GJL-200	1
64	Motor Housing	Cast Iron	A48M Class30B	EN 1561 GJL-200	1
65	Outer Cover	Steel	A283 Grade D	EN 10025 S275	1
71	Shaft Sleeve	Stainless Steel	S 40300	1.4000	1
90	Leak Sensor (Electrode)	Stainless Steel	S 30300	1.4305	1

TSURUMI PUMP
GSZ-4 SERIES
HIGH VOLUME - DEWATERING PUMPS
SAMPLE
SPECIFICATIONS
1. SCOPE OF SUPPLY -

Furnish and install TSURUMI Model _____ Submersible Pump(s).
 Each unit shall be capable of delivering _____ GPM (_____ m³/min) at _____ Feet (_____ m) TDH.
 The pump(s) shall be designed to pump waste water without damage during operation. The pump(s) shall be designed so that the shaft power required (BHP)/(kW) shall not exceed the motor rated output throughout the entire operating range of the pump performance curve.

2. MATERIALS OF CONSTRUCTION -

Construction of major parts of the pumping unit(s) shall be gray cast iron, ASTMA48 CLASS 35. Impellers and field adjustable/replaceable, wear plate shall be high chrome iron. Impellers shall be of the multi-vane enclosed solids handling design equipped with back pump out vanes and shall be slip fit to the shaft and key driven. Internal and external surfaces coming into contact with the pumpage shall be protected by a fused polymer coating. All exposed fasteners shall be stainless steel. All units shall be furnished with 150 lb. (10 kg/cm²) flat face flange and NPT companion flange.

3. MECHANICAL SEAL -

All units shall be furnished with a dual inside mechanical shaft seal located completely out of the pumpage, running in a separate oil filled chamber and further protected by an exclusionary oil seal located between the bottom seal faces and the fluid being pumped. The oil chamber shall be fitted with a device that shall provide positive lubrication of the top mechanical seal, (down to one third of the standard oil level). The device shall not consume any additional electrical power. Mechanical seals shall be rated to preclude the incursion of water up to 42.6 PSI. (98.4 Ft.) submergence. Units shall have silicon carbide versus silicon carbide upper and lower mechanical seal faces. Mechanical seal hardware shall be stainless steel. Unit(s) shall incorporate seal pressure relief ports. All unit(s) shall be fitted with a replaceable 403 stainless steel shaft sleeve.

4. MOTOR-

The pump motor(s) shall be _____ H p., _____ kW., _____ V., 60 Hz. 3 Phase and shall be NEMA MG-1, Design Type B equivalent. Motor(s) shall be rated at _____ full load amps. Motor(s) shall have a 1.15 service factor and shall be rated for 20 starts per hour. Motor(s) shall be air filled, copper wound, class F or E (60 Hp and above) insulated with built in thermal protection for each winding. Motor shaft shall be 420 stainless steel and shall be supported by two high temperature ball bearings, with a B-10 life rating at best efficiency point of 60,000 hours. The bottom bearing on units 50 Hp shall be two row, double shielded, C3, deep groove type ball bearing. The bottom bearing on units 60 Hp and above shall be two row, re-greasable, C3, angular contact type ball bearing. The top bearing on all units shall be single row, double shielded, C3, deep groove type ball bearing. Motors shall be star-delta start and shall be suitable for across the line start or variable speed applications, utilizing a properly sized variable frequency drive. Motor shall incorporate a steel water cooling jacket.

5. POWER CABLE AND CABLE ENTRANCE -

The pump power cable shall be suitable for submersible pump applications and shall be field replaceable utilizing standard submersible pump cable. The cable entrance shall incorporate built in strain relief and a combination three way mechanical compression sealing. The cable entrance assembly shall contain an anti-wicking block to eliminate water incursion into the motor due to capillary wicking should the power cable be accidentally damaged.