



LH - SERIES DEWATERING PUMP

SPECIFICATIONS

■ FEATURES

1. Semi-open, high chrome iron impeller with replaceable / adjustable high chrome Iron wear rings, increases wear resistance, when pumpage contains abrasive particles.
2. Double inside mechanical seals with silicon carbide faces, (both top and bottom) running in an oil filled chamber and further protected by a lip seal running against a replaceable, 430 stainless steel shaft sleeve, provides for the most durable seal design available.
3. Highly efficient, continuous duty air filled, copper wound motor with class B, F insulation minimizes the cost of operation.
4. Built in thermal & amperage sensing protector prevents motor failure due to

overloading or accidental run -dry conditions.

5. Double shielded, permanently lubricated, high temperature C3 ball bearings rated for a B-10 life of 60,000 hours, extend operational life.
6. Top discharge, flow-thru design enables operation at low water levels for extended periods.

■ APPLICATIONS

1. Commercial, industrial wastewater and construction site drainage.
2. Effluent transfer.
3. Decorative waterfalls and fountains.
4. Raw water supply from rivers or lakes.



■ SPECIFICATIONS

Discharge Size
 Horsepower Range
 Performance Range Capacity
 Head
 Maximum water temperature
 Materials of Construction
 Casing
 Impeller
 Shaft
 Motor Frame
 Fasteners
 Seal Pressure Relief Ports
 Mechanical Seal
 Elastomers
 Impeller Type
 Solids Handling Capability

 Bearings

 Motor Nomenclature
 Type, Speed, Hz.
 Voltage, Phase
 Insulation

 Accessories

 Operational Mode

■ STANDARD

3" ~ 8" NPT (80 mm ~ 200 mm)
 4 ~ 150 HP. (3 ~ 110 Kw)
 26.4 ~ 1717.0 GPM. (0.1 ~ 6.5 m³/min)
 20.5 ~ 604.0 Ft. (6.25 ~ 184.1m)
 104° F. (40° C.)

 Cast Iron , Ductile Cast Iron
 High Chrome Cast Iron
 420 Stainless Steel
 Cast Iron
 304 Stainless Steel
 50 - 150HP (37 - 110 kW)
 Silicon Carbide
 NBR (Nitrile Butadiene Rubber)
 Semi-open, solids handling.
 0.236 - 0.787" (6 - 20mm)

 Prelubricated, Double Shielded

 Air Filled, 3600 RPM, 60 Hz.
 208/230/460/575 V., 3 Phase.
 Class B , F

 Submersible Power Cable
 50 - 65' (15 - 20m)

 Manual

■ OPTIONS

Length as Required.

 TS-303 Float Switch



LH - SERIES DEWATERING PUMP

PERFORMANCE RANGE

GROUP PERFORMANCE RANGE

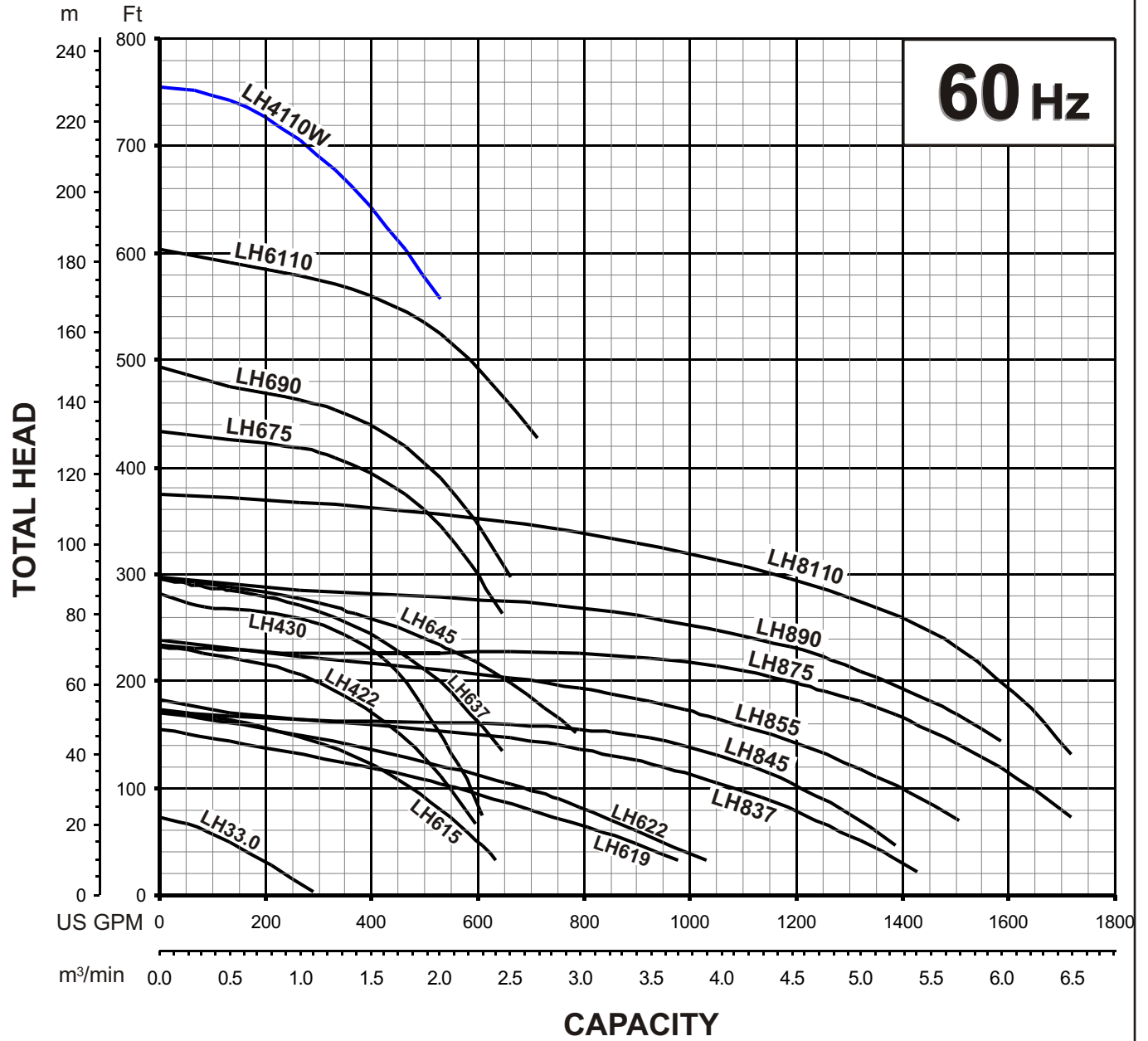



LH - SERIES DEWATERING PUMPS

PERFORMANCE CURVE

| MODEL | BORE | HP | KW | RPM | SOLIDS DIA | LIQUID | SG. | VISCOSITY | TEMP. |
|-----------------|----------|-----------|-----------|----------|-----------------|-----------------|------------|------------|-------|
| LH8110-61 | 8"/200mm | 150 | 110 | 3570 | 0.787"/20mm | Water | 1.0 | 1.123 cSt. | 60°F |
| PUMP TYPE | PHASE | VOLTAGE | AMPERAGE | HZ | STARTING METHOD | INS. CLASS | | | |
| Dewatering Pump | 3 | 460 / 575 | 181 / 145 | 60 | Star-Delta | F | | | |
| CURVE No. | DATE | PHASE | VOLTAGE | AMPERAGE | HZ | STARTING METHOD | INS. CLASS | | |
| - | - | - | - | - | - | - | - | | |

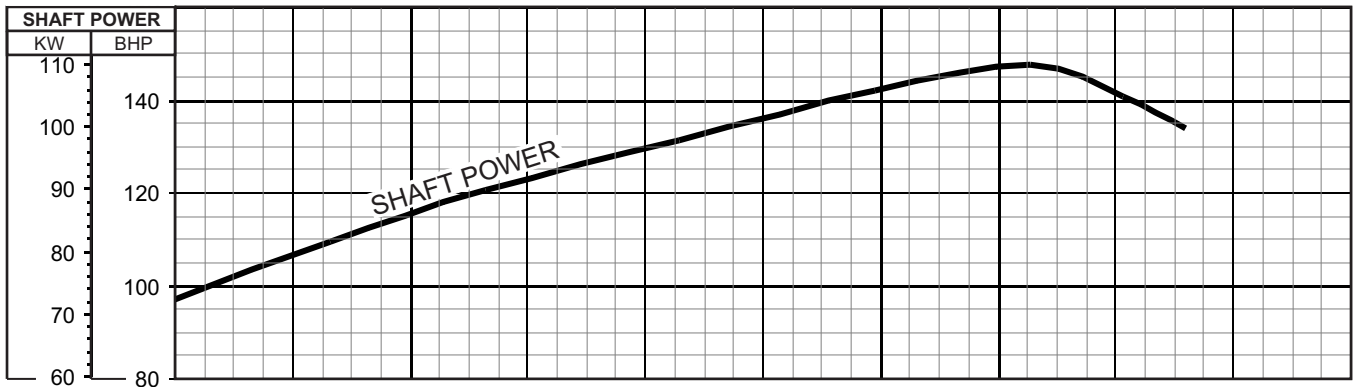
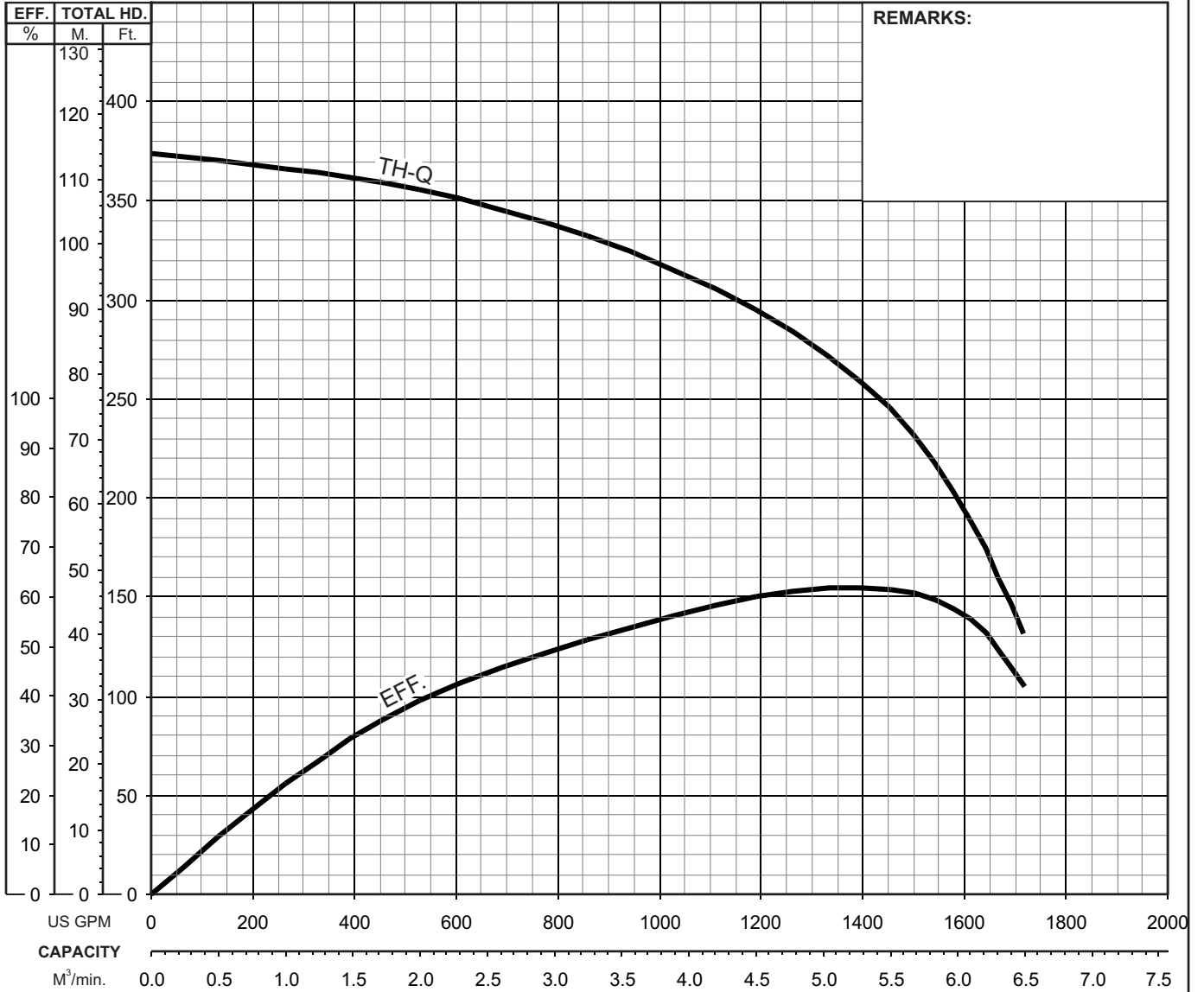



**LH - SERIES
DEWATERING PUMPS**

DIMENSIONS

**LH6110-61
LH8110-61**

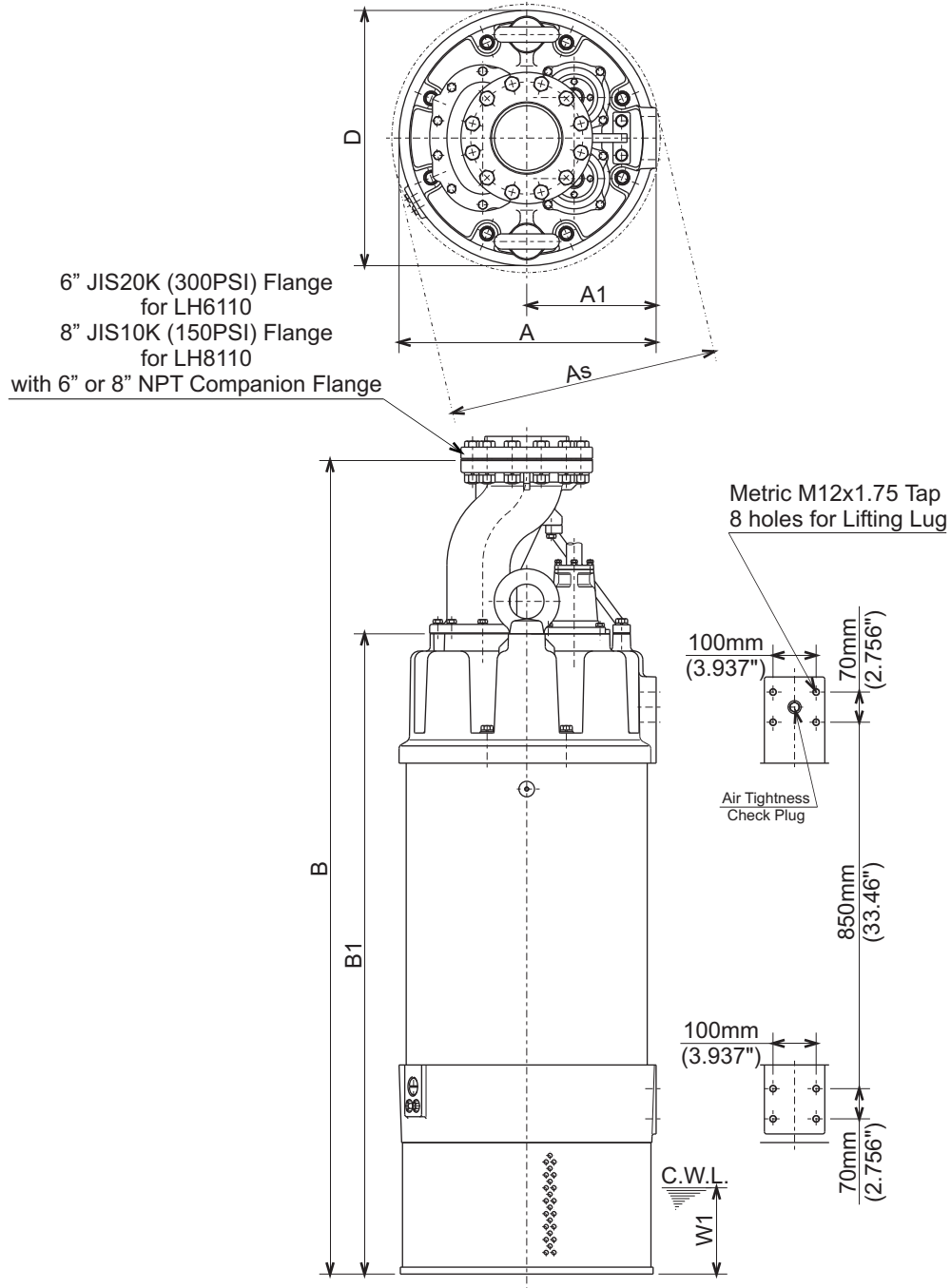

C.W.L. : Continuous running Water Level

DIMENSIONS:USCS (Inch)

| Model | HP | NOM. SIZE | Pump & Motor | | | | | | C.W.L. | | Wt. (lbs.) |
|-----------|-----|-----------|--------------|--------|----------|---------|---------|---------|--------|------|------------|
| | | | A | As | A1 | B | B1 | D | W1 | | |
| LH6110-61 | 150 | 6" | 23 7/16 | 24 1/2 | 11 13/16 | 74 5/16 | 58 7/16 | 23 5/16 | 7 7/8 | 2670 | |
| LH8110-61 | 150 | 8" | 23 7/16 | 24 1/2 | 11 13/16 | 74 5/16 | 58 7/16 | 23 5/16 | 7 7/8 | 2670 | |

DIMENSIONS:METRIC (mm)

| Model | kW | NOM. SIZE | Pump & Motor | | | | | | C.W.L. | | Wt. (kg) |
|-----------|-----|-----------|--------------|-----|-----|------|------|-----|--------|------|----------|
| | | | A | As | A1 | B | B1 | D | W1 | | |
| LH6110-61 | 110 | 150 | 596 | 622 | 300 | 1887 | 1485 | 592 | 200 | 1210 | |
| LH8110-61 | 110 | 200 | 596 | 622 | 300 | 1887 | 1485 | 592 | 200 | 1210 | |



TSURUMI PUMP

**LH - SERIES
DEWATERING PUMPS**

SECTIONAL VIEW

**LH6110-61
LH8110-61**

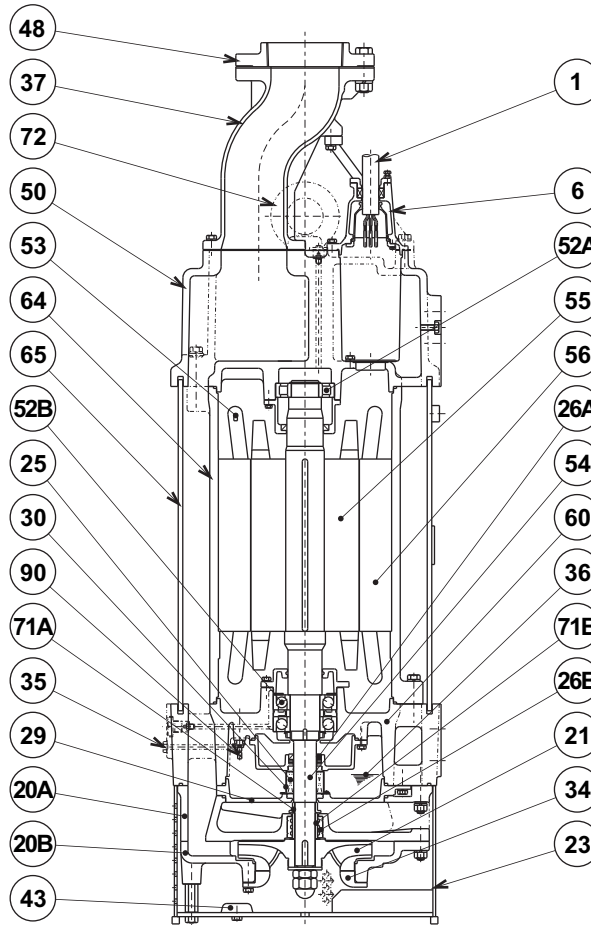

| ITEM# | DESCRIPTION | MAIN MATERIAL / NOTE | RELATED ASTM, AISI CODE | RELATED EN CODE | Q'TY |
|-------|---------------------------|---|-------------------------|---------------------|-------|
| 1 | Power Cable | Chloroprene Sheath AWG 1/3, 4/1, 14/3 -65ft | | | 1 |
| | Power Cable | Chloroprene Sheath AWG 1/3 -65ft | | | 1 |
| 6 | Stuffing Box | Cast Iron | A48M Class30B | EN 1561 GJL-200 | 2 |
| 20A | Upper Pump Casing | Cast Iron | A48M Class30B | EN 1561 GJL-200 | 1 |
| 20B | Lower Pump Casing | Ductile Cast Iron | A536 100-70-03 | EN 1563 GJS-700-2 | 1 |
| 21 | Impeller | High Chrome Cast Iron | A532 Class III Type A | DIN 1695 G-X260Cr27 | 1 |
| 23 | Suction Strainer | Steel (Cold Rolled) | A109/A1008 | EN 10130 | 1 |
| 25 | Mechanical Seal | Silicon Carbide / H-50T | | | 1 |
| 26A | Oil Seal | Nitrile Butadiene Rubber / SC-507210 | | | 1 |
| 26B | Labyrinth Ring | Stainless Steel | S 40300 | 1.4000 | 1 |
| 29 | Oil Casing | Cast Iron | A48M Class30B | EN 1561 GJL-200 | 1 |
| 30 | Oil Lifter | Steel (Cold Rolled) | A109/A1008 | EN 10130 | 1 |
| 34 | Suction Mouth | High Chrome Cast Iron | A532 Class III Type A | DIN 1695 G-X260Cr27 | 1 |
| 35 | Oil Plug | Stainless Steel | S 30400 | 1.4301 | 2 |
| 36 | Lubricant | Turbine Oil ISO VG32 or SAE10W-20 | | | |
| 37 | Flanged Discharge Pipe | Ductile Cast Iron / 6" JIS20K or 8" JIS 10K | A536 100-70-03 | EN 1563 GJS-700-2 | 1 |
| 43 | Cathodic Protection Plate | Aluminium Alloy | | | 3 |
| 48 | Companion Flange | Cast Iron / NPT 6"or 8" | A48M Class30B | EN 1561 GJL-200 | 1 |
| 50 | Motor Head Cover | Cast Iron | A48M Class30B | EN 1561 GJL-200 | 1 |
| 52A | Upper Bearing | #NU312ECM | | | 1 |
| 52B | Lower Bearing | #7313BECBMDB w/ Spacer | | | 1 set |
| 53 | Motor Protector | | | | 3 |
| 54 | Shaft | Stainless Steel | S 42000 | 1.4028 | 1 |
| 55 | Rotor | | | | 1 |
| 56 | Stator | | | | 1 |
| 60 | Bearing Housing | Cast Iron | A48M Class30B | EN 1561 GJL-200 | 1 |
| 64 | Motor Housing | Cast Iron | A48M Class30B | EN 1561 GJL-200 | 1 |
| 65 | Outer Cover | Steel | A283 Grade D | EN 10025 S275 | 1 |
| 71A | Shaft Sleeve (Upper) | Stainless Steel | S 40300 | 1.4000 | 1 |
| 71B | Shaft Sleeve (Lower) | Stainless Steel | S 40300 | 1.4000 | 1 |
| 72 | Lifting Lug Bolt | Steel | A283 Grade D | EN 10025 S275 | 2 |
| 90 | Leakage Sensor Electrode | Stainless Steel | S 30300 | 1.4305 | 1 |

TSURUMI PUMP
**LH - SERIES
DEWATERING PUMPS**
**SAMPLE
SPECIFICATIONS**

1. SCOPE OF SUPPLY -

Furnish and install TSURUMI Model _____ Submersible Pump(s).
Each unit shall be capable of delivering _____ GPM (_____ m³/min) at _____ Feet (_____ m) TDH. The pump(s) shall be designed to pump waste water or effluent without damage during operation. The pump(s) shall be designed so that the shaft power required (BHP)/(kW) shall not exceed the motor rated output throughout the entire operating range of the pump performance curve. Pump(s) shall be of the top discharge, flow through design.

2. MATERIALS OF CONSTRUCTION -

Construction of major parts of the pumping unit(s) shall be gray cast iron, ASTMA48 CLASS 35. Impellers and field adjustable/replaceable wear plates shall be high chrome iron. Internal and external surfaces coming into contact with the pumpage shall be protected by a fused polymer coating. All exposed fasteners shall be stainless steel. All units up to 75 HP and LH875/890/8110 shall be furnished with 150 lb. (10 kg/cm²) flat face flange and NPT companion flange. LH675/690/6110 shall be furnished with 300 lb. (20 kg/cm²) flat face flange and NPT companion flange. Impellers shall be of the multi-vane enclosed solids handling design equipped with back pump out vanes and shall be slip fit to the shaft and key driven. The unit(s) shall include built in cathodic protection.

3. MECHANICAL SEAL -

All units shall be furnished with a dual inside mechanical shaft seal located completely out of the pumpage, running in a separate oil filled chamber and further protected by an exclusionary oil seal located between the bottom seal faces and the fluid being pumped. The oil chamber shall be fitted with a device that shall provide positive lubrication of the top mechanical seal, (down to one third of the standard oil level). The device shall not consume any additional electrical power. Mechanical seals shall be rated to preclude the incursion of water up to 42.6 PSI (98.4 Ft.) submergence. Units shall have silicon carbide mechanical seal faces. Mechanical seal hardware shall be stainless steel. Unit(s) shall incorporate seal pressure relief ports. Units 75 Hp and above shall be supplied with electrode type seal sensor. All unit(s) shall be fitted with a replaceable shaft sleeve.

4. MOTOR-

The pump motor(s) shall be _____ H P., _____ kW., _____ V., 60 Hz. 3 Phase and shall be NEMA MG-1, Design Type B equivalent. Motor(s) shall be rated at full load amps. Motor(s) shall have a 1.15 service factor and shall be rated for 20 starts per hour. Motor(s) shall be air filled, copper wound, class F or B (up to 30 HP) insulated with built in thermal protection for each winding. Motor shaft shall be 420 stainless steel and shall be supported by two high temperature bearings, with a B-10 life rating at best efficiency point of 60,000 hours. On units up to 60 HP, the bottom bearing shall be two row, double shielded, C3, deep groove type ball bearing, and the top bearing shall be single row, double shielded, C3, deep groove type ball bearing. On units 75 HP and above, the bottom bearing shall be re-greasable, two row, C3, angular contact type ball bearing, and the top bearing shall be re-greasable, single row, C3, cylindrical roller bearing. Motors shall be D.O.L. or star-delta start (40 HP and above), and shall be suitable for across the line start or variable speed applications, utilizing a properly sized variable frequency drive.

5. POWER CABLE AND CABLE ENTRANCE -

The pump power cable shall be suitable for submersible pump applications and shall be field replaceable utilizing standard submersible pump cable. The cable entrance shall incorporate built in strain relief and a combination three way mechanical compression sealing. The cable entrance assembly shall contain a anti-wicking block to eliminate water incursion into the motor due to capillary wicking should the power cable be accidentally damaged.