



**C - SERIES**  
**SEWAGE & WASTE WATER CUTTER PUMPS**

**SPECIFICATIONS**

**FEATURES**

1. Single & Multi-Vane, Cast Iron, impellers with Tungsten Carbide tip., and serrated, High Chrome Cast Iron, field replaceable/ adjustable cutter plate, reduces solids to impeller thrulett size, providing for highly efficient, and trouble free pumping of raw sewage and waste water.
2. Double inside mechanical seals with silicon carbide faces, running in an oil filled chamber and further protected by a lip seal, equipped with an oil lifter, (2Hp. and above.), provides for the most durable seal design Available.
3. Highly efficient, continuous duty, air filled, copper wound motor with class F, B, E insulation minimizes the cost of operation.

4. Built in thermal, protector prevents motor failure due to overloading, single phasing (in three phase units), or accidental run -dry conditions.
5. Double shielded, permanently lubricated, high temperature C3 ball bearings rated for a B-10 life of 60,000 hours, extend operational life.



**APPLICATIONS**

1. Residential, commercial, industrial sewage, effluent, wastewater and site drainage.
2. Food and poultry, waste processing.
3. Dairy and Hog waste handling.
4. Problem sump applications with unpredictable solids incursion.

**IMPELLER**

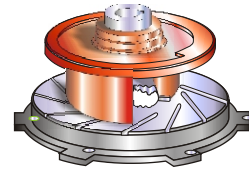

**CUTTER PLATE**



**SPECIFICATIONS**

- Discharge Size
- Horsepower Range
- Performance Range Capacity Head
- Maximum water temperature
- Materials of Construction
  - Casing
  - Impeller
  - Cutter Plate
  - Shaft
  - Motor Frame
  - Fasteners
- Mechanical Seal
  - Elastomers
- Impeller Type
- Solids Handling Capability
- Bearings
- Motor Nomenclature
  - Type, Speed, Hz.
  - Voltage, Phase
- Insulation
- Accessories

**STANDARD**

- 2 ~ 8" N.P.T. (50 ~ 200 mm)
- 1 ~ 30 Hp. (.75 ~ 22 KW)
- 39.6 ~ 1585.0 G.P.M. (.15 ~ 6.0 m<sup>3</sup>/min)
- 4.9 Ft. ~ 230.0 Ft. (1.5 ~ 70.1 m)
- 104° F. (40° C.)
- ASTM 48 Class 35 Cast Iron
- ASTM 48 Class 35 Cast Iron/TC
- High Chrome Cast Iron, (HCR)
- 420,403 Stainless Steel
- ASTM 48 Class 30 Cast Iron
- 304 Stainless Steel
- Silicon Carbide
- NBR (Nitril Buna Rubber)
- Semi-Open, Cutter Type
- 0.79 ~ 3.62 (20 ~ 92 mm)
- Pre-lubricated, Double Shielded
- Air Filled, 3600/1800/1200 Rpm, 60 Hz.
- 115V. or 230V. (1 Phase)
- 208-230 or 440, 460 or 575V. (3 Phase)
- Class E, B, F
- Submersible Power Cable 32' (10 m)

**OPTIONS**

- Dry-Pit
- Nema 3R inverter available for 230 V., 1 Ph. operation (1~5 Hp.)
- Length as Required
- TOS Slide rail system

**GROUP PERFORMANCE RANGE**

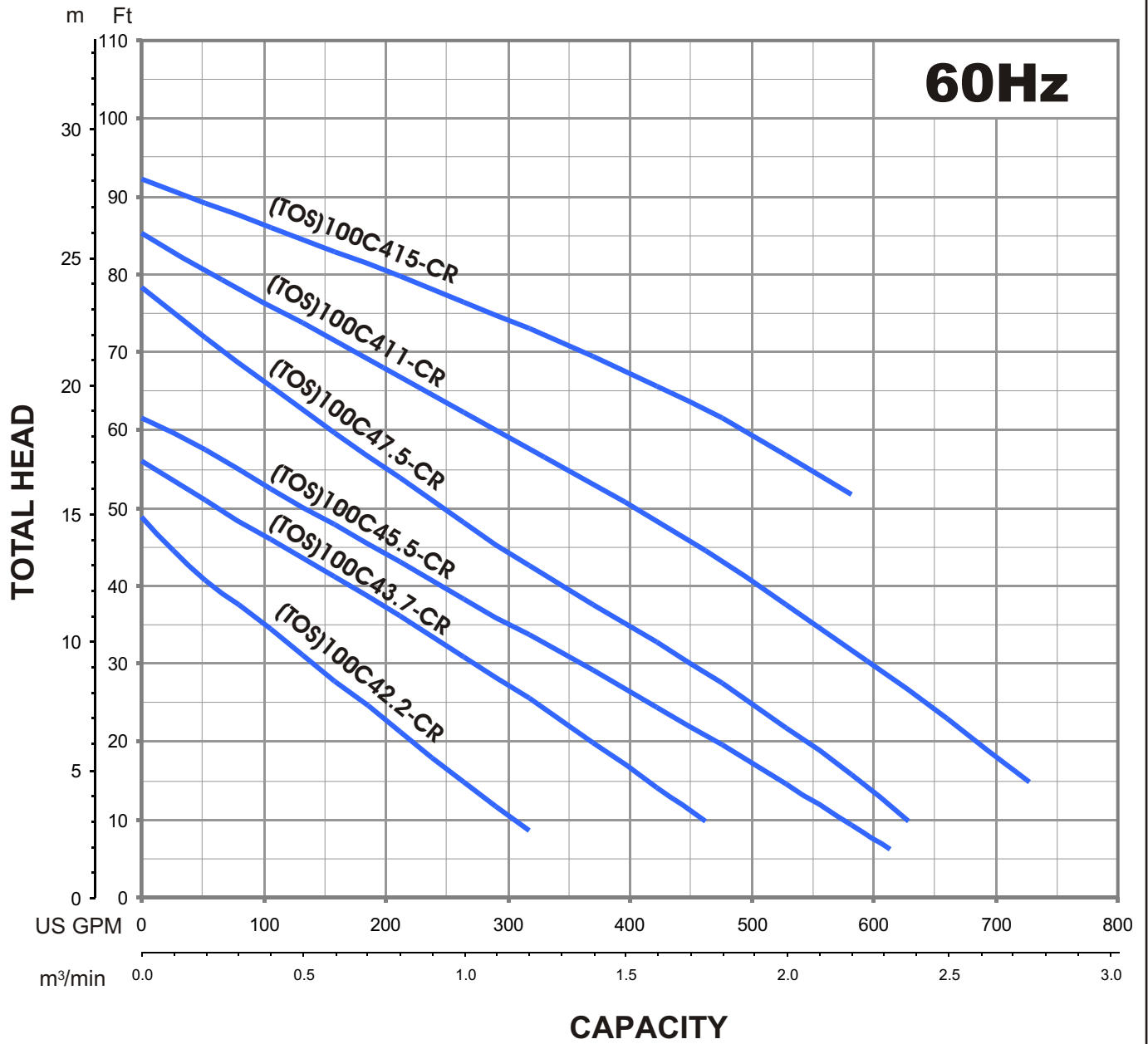



**TSURUMI PUMP**

**C-SERIES  
CUTTER - TYPE - SEWAGE & WASTEWATER PUMPS**

**PERFORMANCE  
CURVE**

MODEL	BORE	HP	KW	RPM	SOLIDS DIA.	LIQUID	SG.	VISCOSITY	TEMP.
(TOS)100C43.7-CR -62	4"/100mm	5	3.7	1690	2.17"/55mm	Water	1.0	1.123cSt.	60°F
PUMP TYPE	PHASE	VOLTAGE	AMPERAGE	HZ	STARTING METHOD	INS.CLASS			
Cutter-Type-Sewage&Wastewater	3	208-230 / 460 /575	15.0-13.8 / 6.9 / 5.4	60	Direct On Line	E			
CURVE No.	DATE	PHASE	VOLTAGE	AMPERAGE	HZ	STARTING METHOD	INS.CLASS		
-	-	-	-	-	-	-	-		

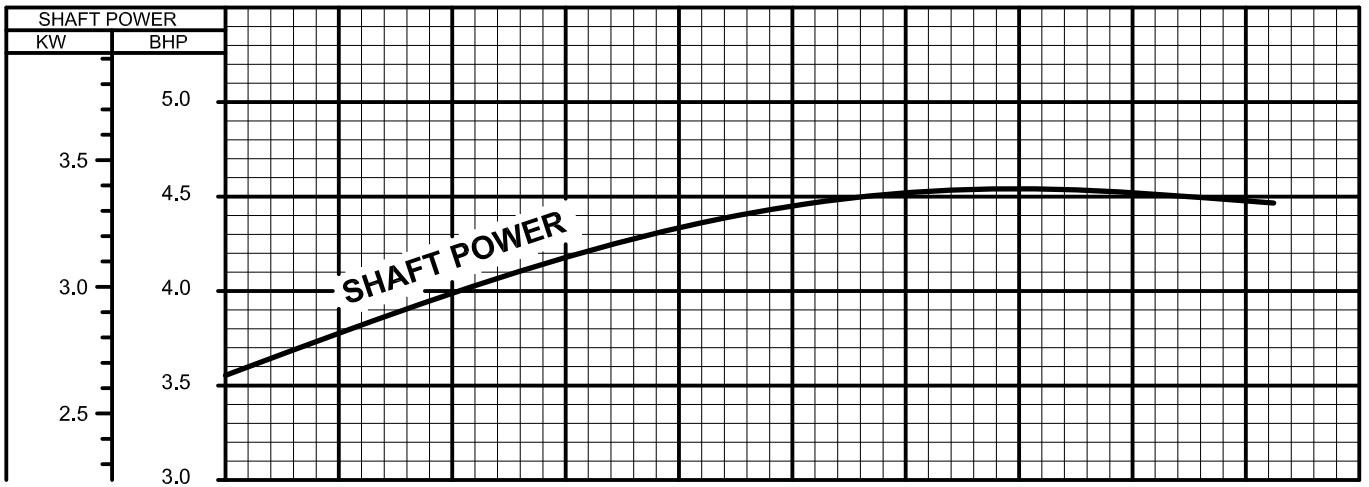
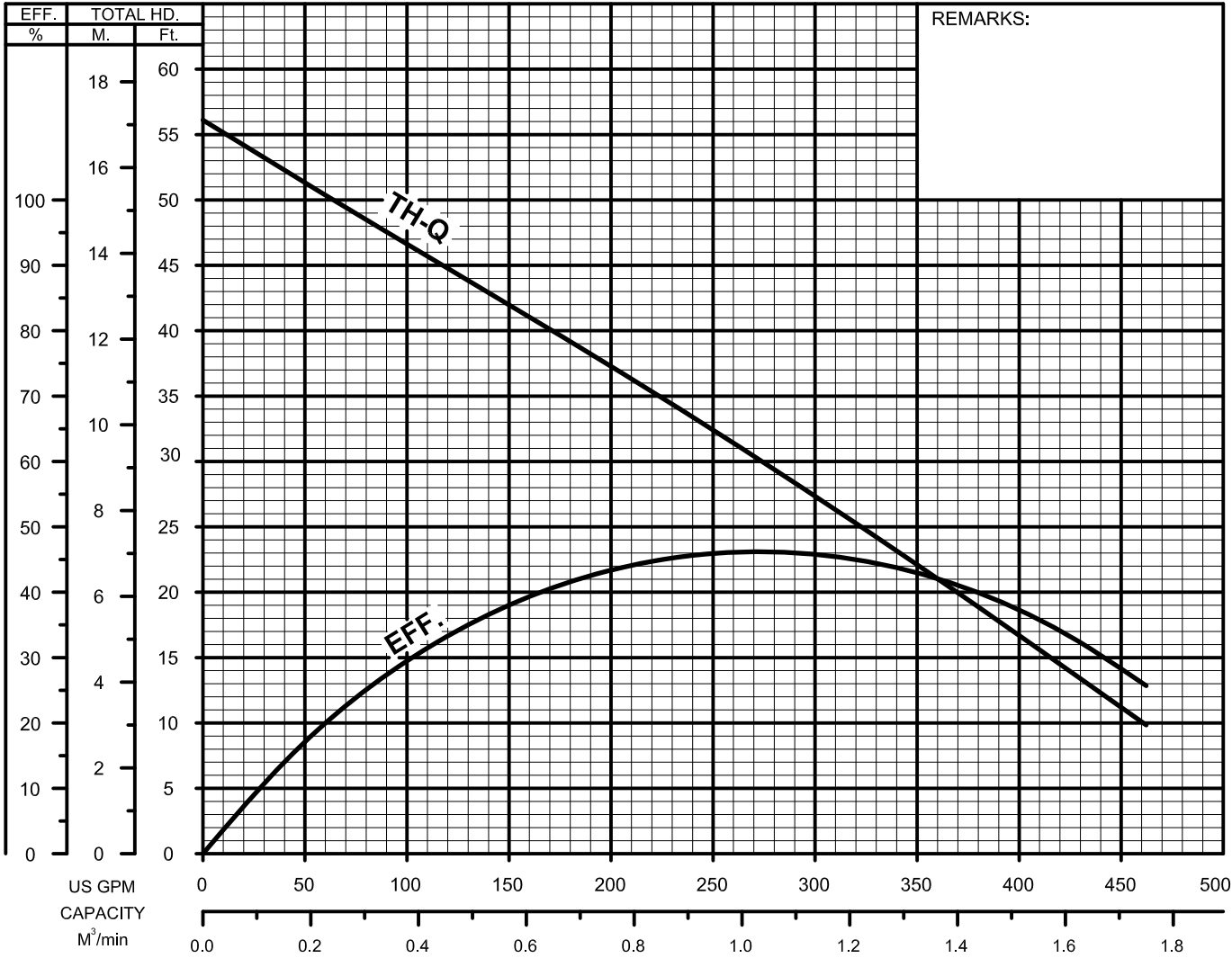

<b>TSURUMI PUMP</b>	<b>C-SERIES</b> <b>CUTTER - TYPE - SEWAGE &amp; WASTEWATER PUMPS</b>	<b>DIMENSIONS</b>
---------------------	---	-------------------

**100C43.7-CR -63 (3"Dis.)**

Bend model:  
BEND80-80 ANSI

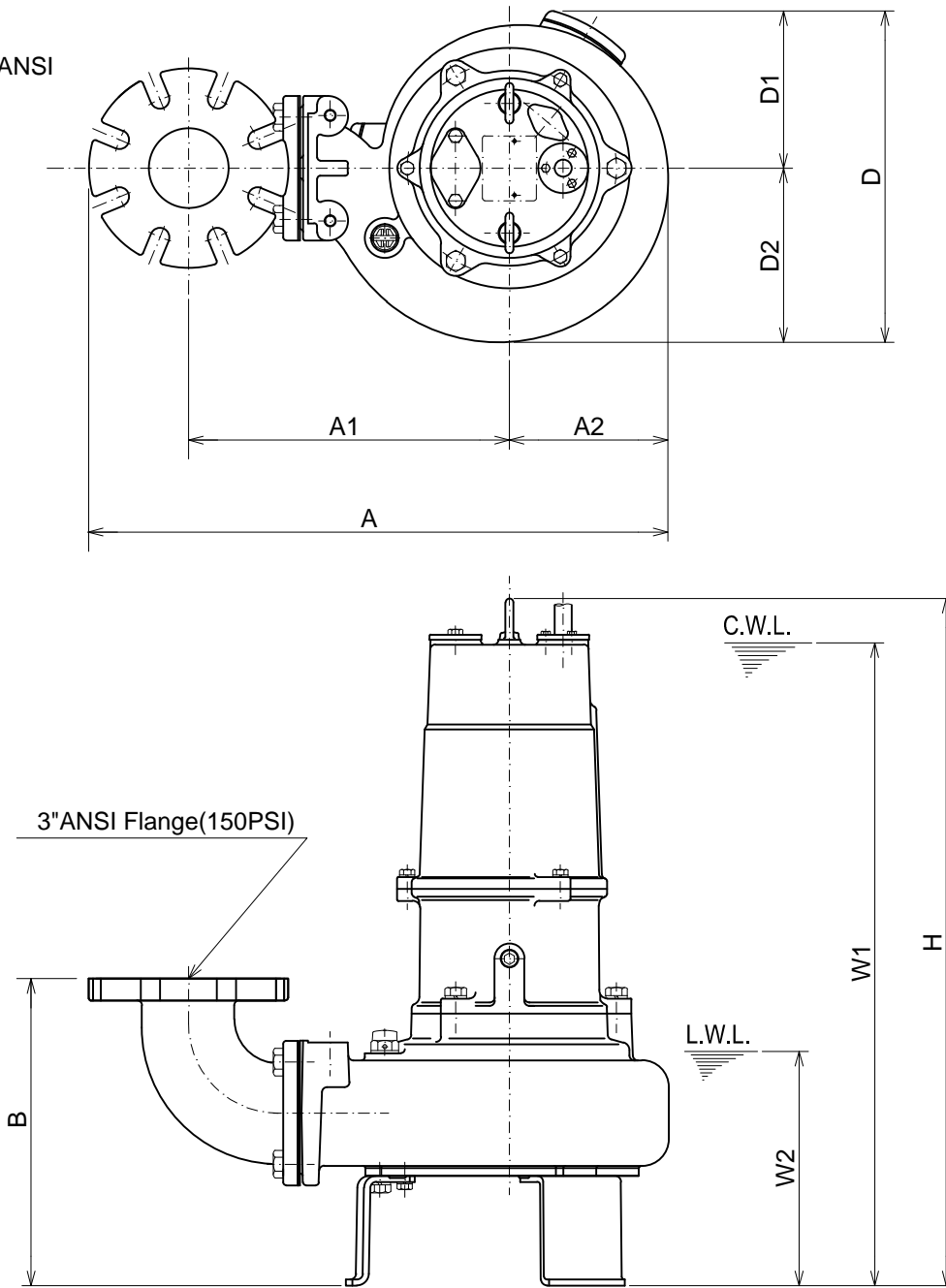

C.W.L. :Continuous running Water Level  
L.W.L. :Lowest running Water Level

**DIMENSIONS:USCS(Inch)**

Model	HP	NOM. SIZE	Pump & Motor								C.W.L. W1	L.W.L. W2	*Wt. (lbs.)
			A	A1	A2	B	D	D1	D2	H			
100C43.7-CR -63	5	3"	23 3/16	13	6 1/4	12 1/8	13 1/8	6 1/4	6 7/8	27 3/16	25 3/8	9 1/4	175

**DIMENSIONS:METRIC(mm)**

Model	kW	NOM. SIZE	Pump & Motor								C.W.L. W1	L.W.L. W2	*Wt. (kg)
			A	A1	A2	B	D	D1	D2	H			
100C43.7-CR -63	3.7	80	589	330	159	308	333	158	175	690	645	235	79

\*Excluding Cable.



**C-SERIES**  
**CUTTER - TYPE - SEWAGE & WASTEWATER PUMPS**

**DIMENSIONS**

**TOS100C43.7-CR -62 (3"Dis.)**

Guide Rail System  
Model : TOS3-80-80 ANSI  
Wt. : 64lb.(29kg)

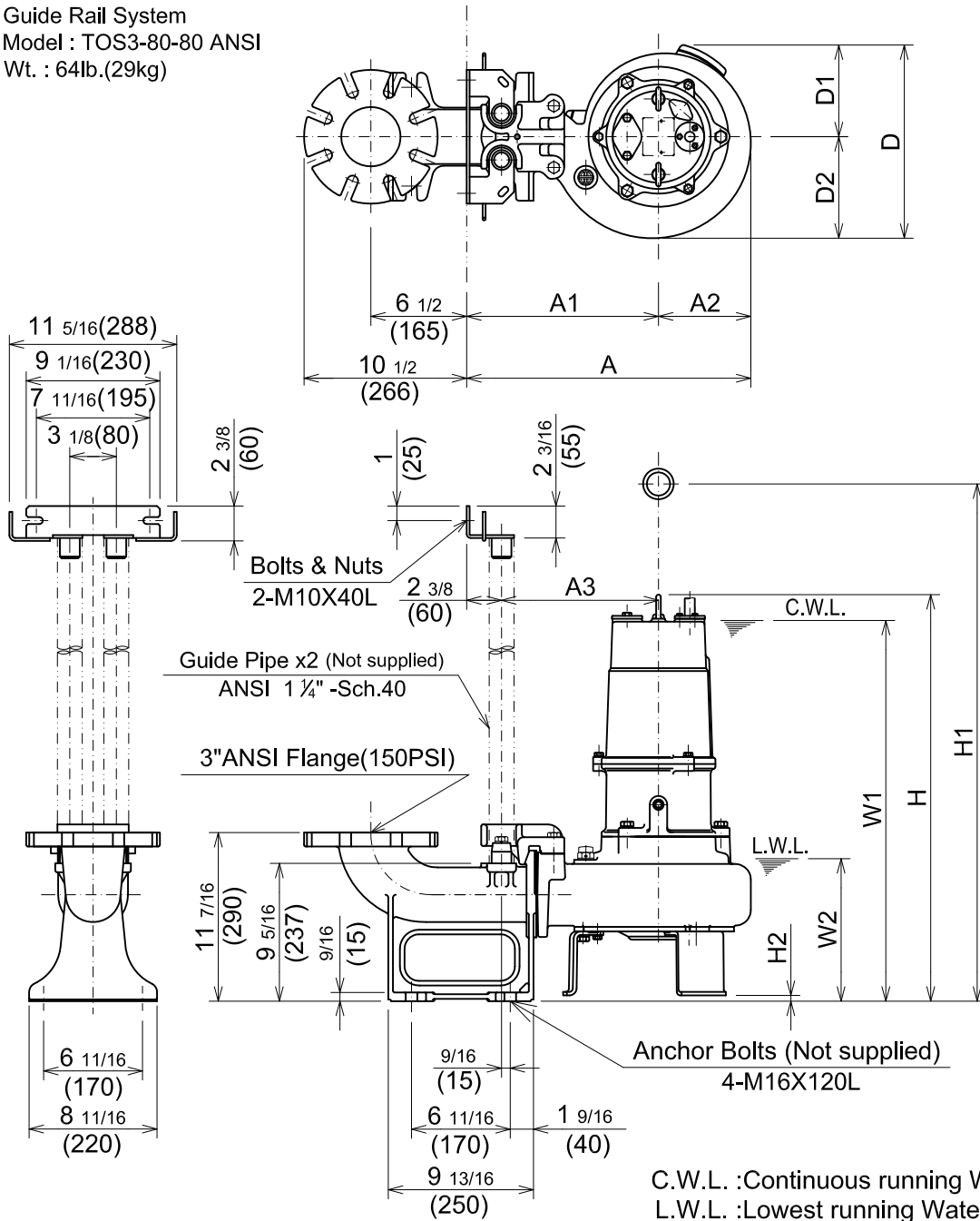

C.W.L. :Continuous running Water Level  
L.W.L. :Lowest running Water Level

**DIMENSIONS:USCS(Inch)**

Model	HP	NOM. SIZE	Pump & Motor									C.W.L. W1	L.W.L. W2	*Wt. (lbs.)	
			A	A1	A2	A3	D	D1	D2	H	H1				H2
TOS100C43.7-CR -62	5	3"	19 1/4	13	6 1/4	10 5/8	13 1/8	6 7/16	6 1/4	27 9/16	33 7/8	3/8	25 3/4	9 5/8	176

**DIMENSIONS:METRIC(mm)**

Model	kW	NOM. SIZE	Pump & Motor									C.W.L. W1	L.W.L. W2	*Wt. (kg)	
			A	A1	A2	A3	D	D1	D2	H	H1				H2
TOS100C43.7-CR -62	3.7	80	489	330	159	270	333	158	175	700	860	10	655	245	80

\*Excluding TOS & Cable.



**TSURUMI PUMP**

**C-SERIES  
CUTTER - TYPE - SEWAGE & WASTEWATER PUMPS**

**DIMENSIONS**

**100C43.7-CR -63**

Bend model:  
BEND80-100 ANSI

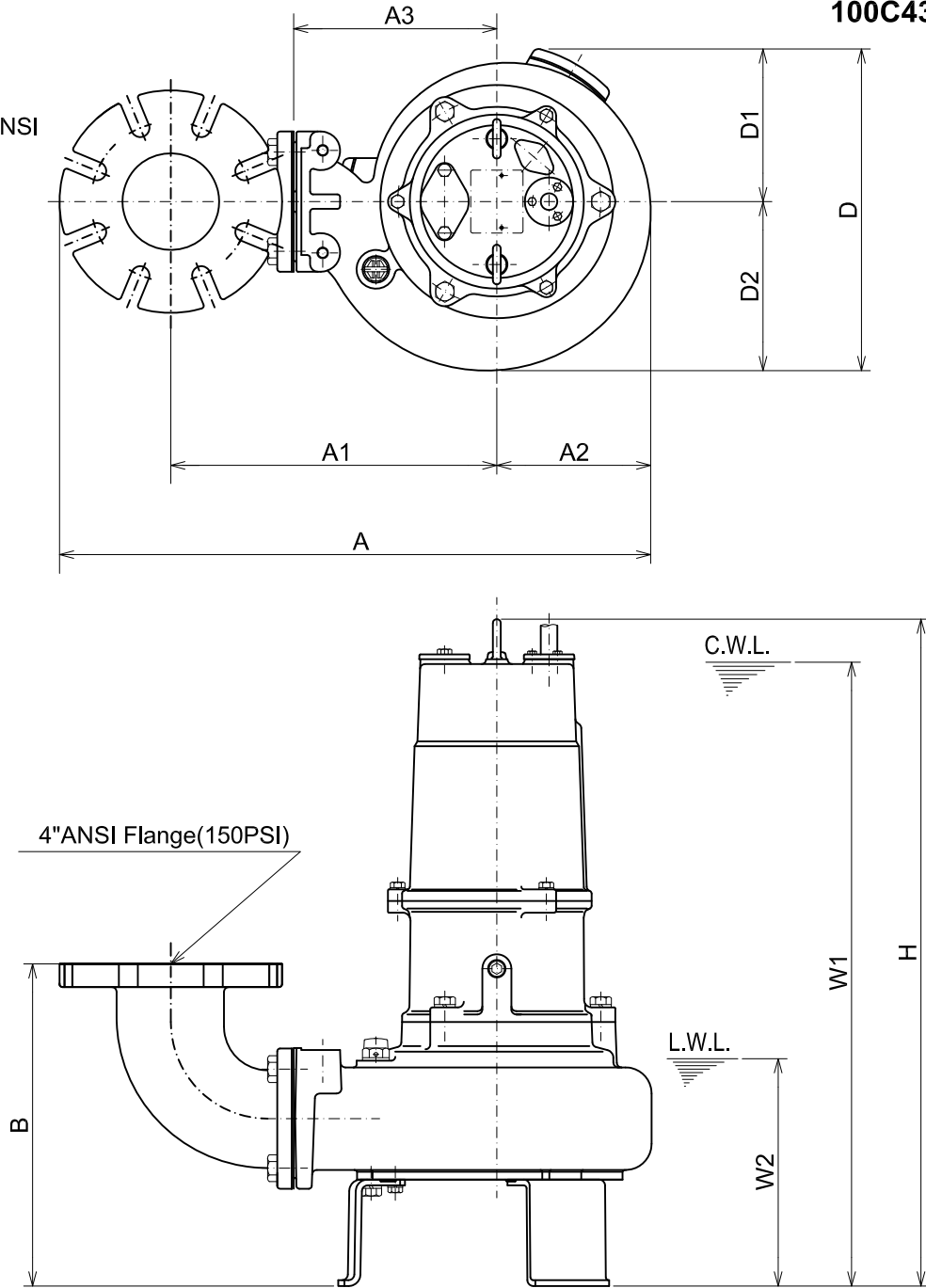

C.W.L. : Continuous running Water Level  
L.W.L. : Lowest running Water Level

**DIMENSIONS:USCS(Inch)**

Model	HP	NOM. SIZE	Pump & Motor									C.W.L. W1	L.W.L. W2	*Wt. (lbs.)
			A	A1	A2	A3	B	D	D1	D2	H			
100C43.7-CR -63	5	4"	24 3/8	13 9/16	6 1/4	8 1/4	13 1/8	13 1/8	6 1/4	6 7/8	27 3/16	25 3/8	9 1/4	183

**DIMENSIONS:METRIC(mm)**

Model	kW	NOM. SIZE	Pump & Motor									C.W.L. W1	L.W.L. W2	*Wt. (kg)
			A	A1	A2	A3	B	D	D1	D2	H			
100C43.7-CR -63	3.7	100	619	345	159	210	333	333	158	175	690	645	235	83

\*Excluding Cable.

**TOS100C43.7-CR -63**

Guide Rail System  
Model : TOS3-80-100 ANSI  
Wt. : 68lb.(31kg)

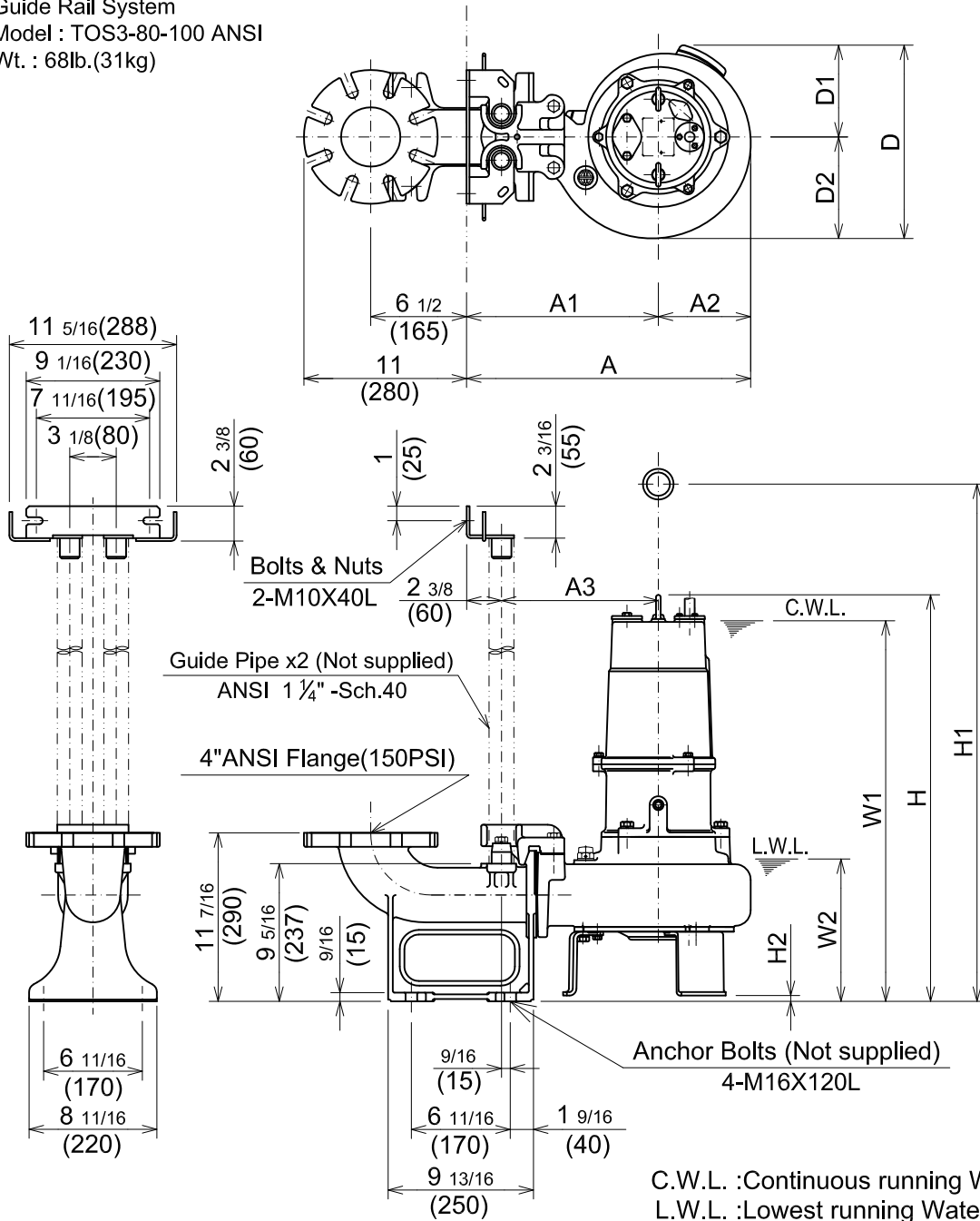

C.W.L. :Continuous running Water Level  
L.W.L. :Lowest running Water Level

**DIMENSIONS:USCS(Inch)**

Model	HP	NOM. SIZE	Pump & Motor									C.W.L. W1	L.W.L. W2	*Wt. (lbs.)	
			A	A1	A2	A3	D	D1	D2	H	H1				H2
TOS100C43.7-CR -63	5	4"	19 1/4	13	6 1/4	10 5/8	13 1/8	6 7/16	6 1/4	27 9/16	33 7/8	3/8	25 3/4	9 5/8	176

**DIMENSIONS:METRIC(mm)**

Model	kW	NOM. SIZE	Pump & Motor									C.W.L. W1	L.W.L. W2	*Wt. (kg)	
			A	A1	A2	A3	D	D1	D2	H	H1				H2
TOS100C43.7-CR -63	3.7	100	489	330	159	270	333	158	175	700	860	10	655	245	80

\*Excluding TOS & Cable.



**TSURUMI PUMP**

**C-SERIES  
CUTTER - TYPE - SEWAGE & WASTEWATER PUMPS**

**SECTIONAL VIEW**

**100C43.7-CR -63 (3"Dis.)**

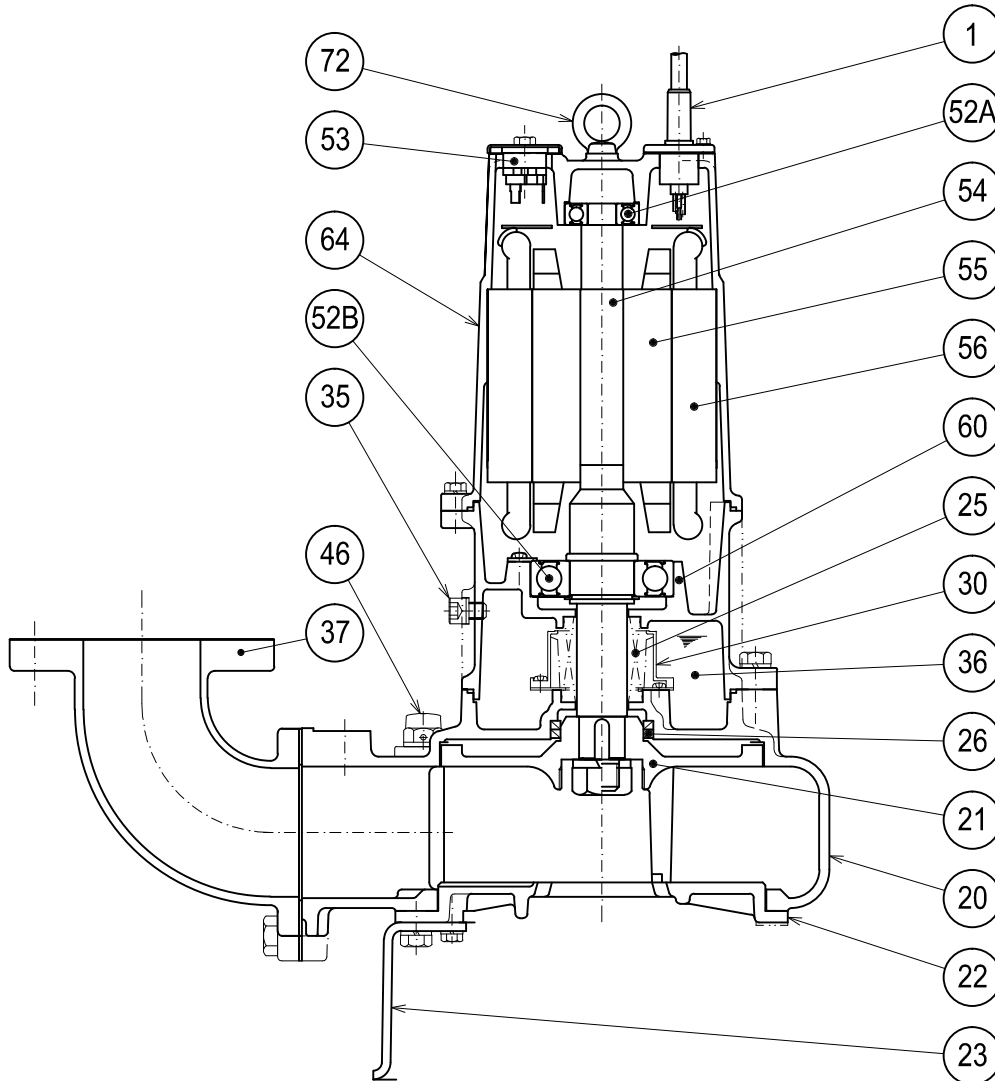

PART#	DESCRIPTION	MAIN MATERIAL / NOTE	RELATED ASTM,AISI CODE	RELATED EN CODE	QTY
1	Power Cable	PVC Sheath AWG 12/4-32ft			1
20	Pump Casing	Cast Iron	A48M Class30B	EN 1561 GJL-200	1
21	Impeller	Cast Iron W/Tungsten Carbide	A48M Class30B	EN 1561 GJL-200	1
22	Suction Cover	High Chrome Cast Iron	A532 Class III TypeA	DIN 1695 G-X260Cr27	1
23	Pump Stand	Steel	A283 Grade D	EN 10025 S275	3
25	Mechanical Seal	Silicon Carbide / H-35			1
26	Oil Seal	NBR / TC58726			2
30	Oil Lifter	PBT Resin W/GF40			1
35	Oil Plug	Stainless Steel	S 30400	1.4301	1
36	Lubricant	Turbine Oil ISO VG32 or SAE 10W-20			
37	Discharge Bend	Cast Iron / 3"ANSI Flange(150PSI)	A48M Class30B	EN 1561 GJL-200	1
46	Air Release Valve	Nylon			1
52A	Upper Bearing	AC-#6304ZZC3			1
52B	Lower Bearing	#6309ZZC3			1
53	Motor Protector				1
54	Shaft	Stainless Steel	S 42000	1.4028	1
55	Rotor				1
56	Stator				1
60	Bearing Housing	Cast Iron	A48M Class25B	EN 1561 GJL-150	1
64	Motor Housing	Cast Iron	A48M Class25B	EN 1561 GJL-150	1
72	Lifting Lug Bolt	Stainless Steel	S 30400	1.4301	2





**TSURUMI PUMP**

**C-SERIES  
CUTTER - TYPE - SEWAGE & WASTEWATER PUMPS**

**SECTIONAL VIEW**

**100C43.7-CR -63**

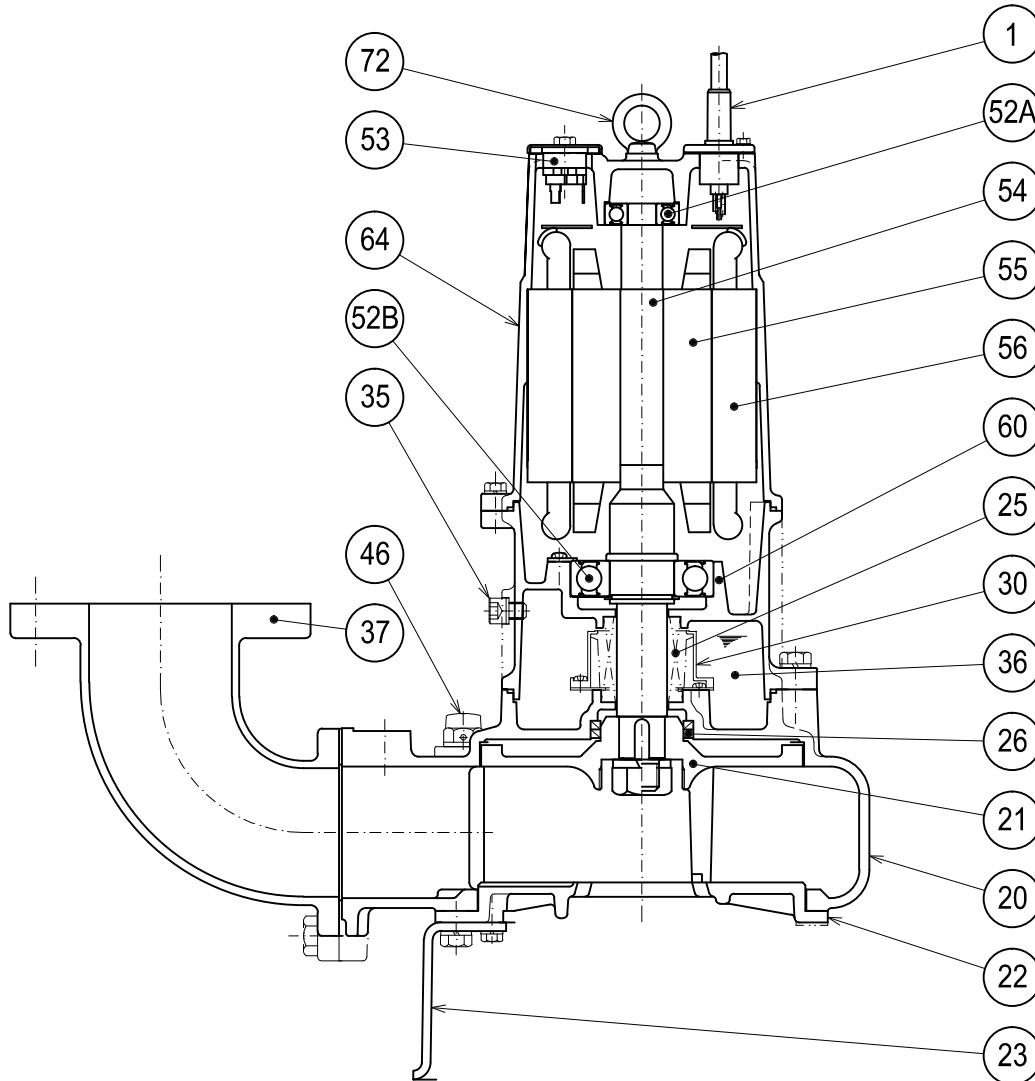

PART#	DESCRIPTION	MAIN MATERIAL / NOTE	RELATED ASTM,AISI CODE	RELATED EN CODE	QTY
1	Power Cable	PVC Sheath AWG 12/4-32ft			1
20	Pump Casing	Cast Iron	A48M Class30B	EN 1561 GJL-200	1
21	Impeller	Cast Iron W/Tungsten Carbide	A48M Class30B	EN 1561 GJL-200	1
22	Suction Cover	High Chrome Cast Iron	A532 Class III TypeA	DIN 1695 G-X260Cr27	1
23	Pump Stand	Steel	A283 Grade D	EN 10025 S275	3
25	Mechanical Seal	Silicon Carbide / H-35			1
26	Oil Seal	NBR / TC58726			2
30	Oil Lifter	PBT Resin W/GF40			1
35	Oil Plug	Stainless Steel	S 30400	1.4301	1
36	Lubricant	Turbine Oil ISO VG32 or SAE 10W-20			
37	Discharge Bend	Cast Iron / 4"ANSI Flange(150PSI)	A48M Class30B	EN 1561 GJL-200	1
46	Air Release Valve	Nylon			1
52A	Upper Bearing	AC-#6304ZZC3			1
52B	Lower Bearing	#6309ZZC3			1
53	Motor Protector				1
54	Shaft	Stainless Steel	S 42000	1.4028	1
55	Rotor				1
56	Stator				1
60	Bearing Housing	Cast Iron	A48M Class25B	EN 1561 GJL-150	1
64	Motor Housing	Cast Iron	A48M Class25B	EN 1561 GJL-150	1
72	Lifting Lug Bolt	Stainless Steel	S 30400	1.4301	2



## C - SERIES SEWAGE & WASTEWATER PUMPS

## SAMPLE SPECIFICATIONS

### 1. SCOPE OF SUPPLY -

Furnish and install TSURUMI Model \_\_\_\_\_ Submersible Pump(s). Each unit shall be capable of delivering \_\_\_\_\_ GPM (\_\_\_\_\_ m<sup>3</sup>/min) at \_\_\_\_\_ Feet (\_\_\_\_\_ m) TDH. The pump(s) shall be designed to pump waste water, sewage or effluent containing solids without damage during operation. The pump(s) shall be designed so that the shaft power required (BHP)/(kW) shall not exceed the motor rated output throughout the entire operating range of the pump performance curve. Pump unit(s) shall be designed so that cavitation will not occur at open discharge. The pump discharge size shall be \_\_\_\_\_ inch, (\_\_\_\_\_ mm).

### 2. MATERIALS OF CONSTRUCTION -

Construction of major parts of the pumping unit(s) including pump casing, impeller, and discharge elbow shall be manufactured from gray cast iron, ASTM A48 CLASS 35. Unit(s) shall have a field adjustable and or replaceable, high chrome cast iron cutter plate. Internal and external surfaces coming into contact with the pumpage shall be protected by a fused polymer coating. All exposed fasteners shall be stainless steel. All units shall be furnished with a discharge elbow with 150 lb. (10 kg/cm<sup>2</sup>) flat face flange and NPT companion flange. Impellers shall be of the single or two-vane, semi-open, solids handling design equipped with tungsten carbide vane tip and shall be slip fit to the shaft and key driven. The pump casing shall incorporate an air relief valve.

### 3. MECHANICAL SEAL -

All units shall be furnished with a dual inside mechanical shaft seal located completely out of the pumpage, running in a separate oil filled chamber and further protected by an exclusionary oil seal located between the bottom seal faces and the fluid being pumped. Unit 2 Hp. and above shall be fitted with a device that shall provide positive lubrication of top mechanical seal, (down to one third of the standard oil level). The device shall not consume any additional electrical power. Mechanical seals shall rated to preclude the incursion of water up to 42.6 PSI. (98.4 Ft.). Units shall have silicon carbide mechanical seal faces. Mechanical seal hardware shall be stainless steel. Units designed to exceed 42.6 PSI. at shut off head shall incorporate seal pressure relief ports.

### 4. MOTOR -

The pump motor(s) shall be \_\_\_\_\_ Hp., \_\_\_\_\_ kW., \_\_\_\_\_ V., 60 Hz., \_\_\_\_\_ Phase and shall be NEMA MG-1, Design Type B equivalent. Motor(s) shall be rated at \_\_\_\_\_ full load amps. Motor(s) shall have a 1.15 service factor and shall be rated for 20 starts per hour. Motor(s) shall be air filled, copper wound, class E, B, or F insulated with built in thermal protection for each winding. Motor shaft shall be 420 or 403 stainless steel and shall be supported by two permanently lubricated, high temperature ball bearings, with a B-10 life rating at best efficiency point of 60,000 hours. On units up to 10 Hp. (7.5 kW), the bottom bearing shall be single row, double shielded, C3, deep groove type ball bearings. On units 15 Hp. (11 kW) and above, the bottom bearing shall be two row, double shielded, C3, deep groove type ball bearings. The top bearing on all units shall be single row, double shielded, C3, deep groove type ball bearings. Motor housing and bearing housing shall be gray cast iron, ASTM A48 CLASS 30. Motors shall be D.O.L. or Star-delta start (15 Hp. and above), and shall be suitable for across the line start or variable speed applications, utilizing a properly sized variable frequency drive.

### 5. POWER CABLE AND CABLE ENTRANCE -

The pump power cable shall be suitable for submersible pump applications. Units up to 5 Hp. shall be supplied with a cable entrance that incorporates built in strain relief, a one piece, three way mechanical compression seal with a fatigue reducing cable boot. On units 7.5 Hp. and above, the cable entrance shall incorporate built in strain relief, and combination three way mechanical compression sealing with a fatigue reducing/thermal expansion rubber boot. The power cable shall be field replaceable utilizing standard submersible pump cable. The cable entrance assembly on all units shall contain an anti-wicking block to eliminate water incursion into the motor due To capillary wicking should the power cable be accidentally damaged.