



**B - SERIES
SEWAGE & WASTEWATER PUMPS**

SPECIFICATIONS

■ FEATURES

1. Semi-open, Single vane, impellers with field adjustable /replaceable shear plate and, Enclosed Multi-vane, impellers, with field adjustable / replaceable wear plate provides for high wear resistance and enhanced solids handling capability.
2. Highly efficient, continuous duty air filled, copper wound motor with class E, B, F insulation minimizes the cost of operation.
3. Built in thermal protection prevents motor failure due to overloading, accidental run-dry and single phasing in three phase units.
4. Double inside mechanical seals with silicon carbide faces, running in an oil filled chamber, equipped with an oil lifter,, and further protected by an exclusionary oil Seal(s), provides for the most -

- durable seal design available.

5. Double shielded, permanently lubricated, high temperature C3 ball bearings rated for a B-10 life of 60,000 hours provide for extended operational life.

■ APPLICATIONS

1. Commercial, Industrial sewage, wastewater, or effluent transfer.
2. Decorative fountains and aquiculture .
3. Raw water supply from rivers or lakes.

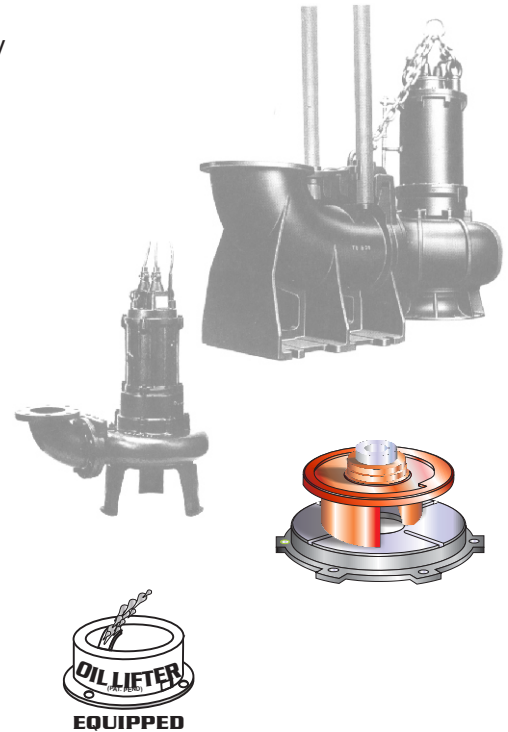

■ SPECIFICATIONS

- Discharge Size
- Horsepower Range
- Performance Range, Capacity Head
- Maximum water temperature
- Materials of Construction
 - Casing
 - Impeller
 - Shaft
 - Motor Frame
 - Fasteners
- Mechanical Seal
 - Elastomers
- Impeller Type
- Solids Handling Capability
- Bearings
- Motor Nomenclature
 - Type, Speed, Hz.
- Voltage, Phase
- Insulation
- Accessories
- Operational Mode

■ STANDARD

- 2" ~ 8" (50 ~ 200 mm)
- 1 Hp. ~ 20 Hp. (.75 kW ~ 20 kW)
- 20 ~ 1850 G.P.M. (.08 ~ 7.00 m³/min)
- 8.2 Ft.~105.0 Ft. (2.5 ~ 32.0m)
- 104° F. (40° C.)
- Cast Iron, ASTM 48 Class 35
- Cast Iron, ASTM 48 Class 35
- 403,420 Stainless Steel
- Cast Iron, ASTM 48 Class 30
- 304 Stainless Steel
- Silicon Carbide
- NBR (Nitril Buna Rubber)
- Semi-open, Enclosed, solids handling.
- .79" ~ 2.95" (20 ~ 75 mm)
- Pre-lubricated, Double Shielded
- Air Filled,
- 3600, 1800 & 1200 Rpm, 60 Hz.
- 115 or 230 (1Phase)
- 208-230, 460 or 575 V., (3 Phase)
- Class E, B, F
- Submersible Power Cable 32' (10 m)
- Manual

■ OPTIONS

- Dry-Pit
- Nema 3R inverter available for 230 V., 1 Ph. operation from 2~5 Hp.
- Length as required.
- TO/TOS Slide Rail System



B - SERIES 8"

SEWAGE & WASTEWATER PUMPS

PERFORMANCE
CURVE

GROUP PERFORMANCE RANGE

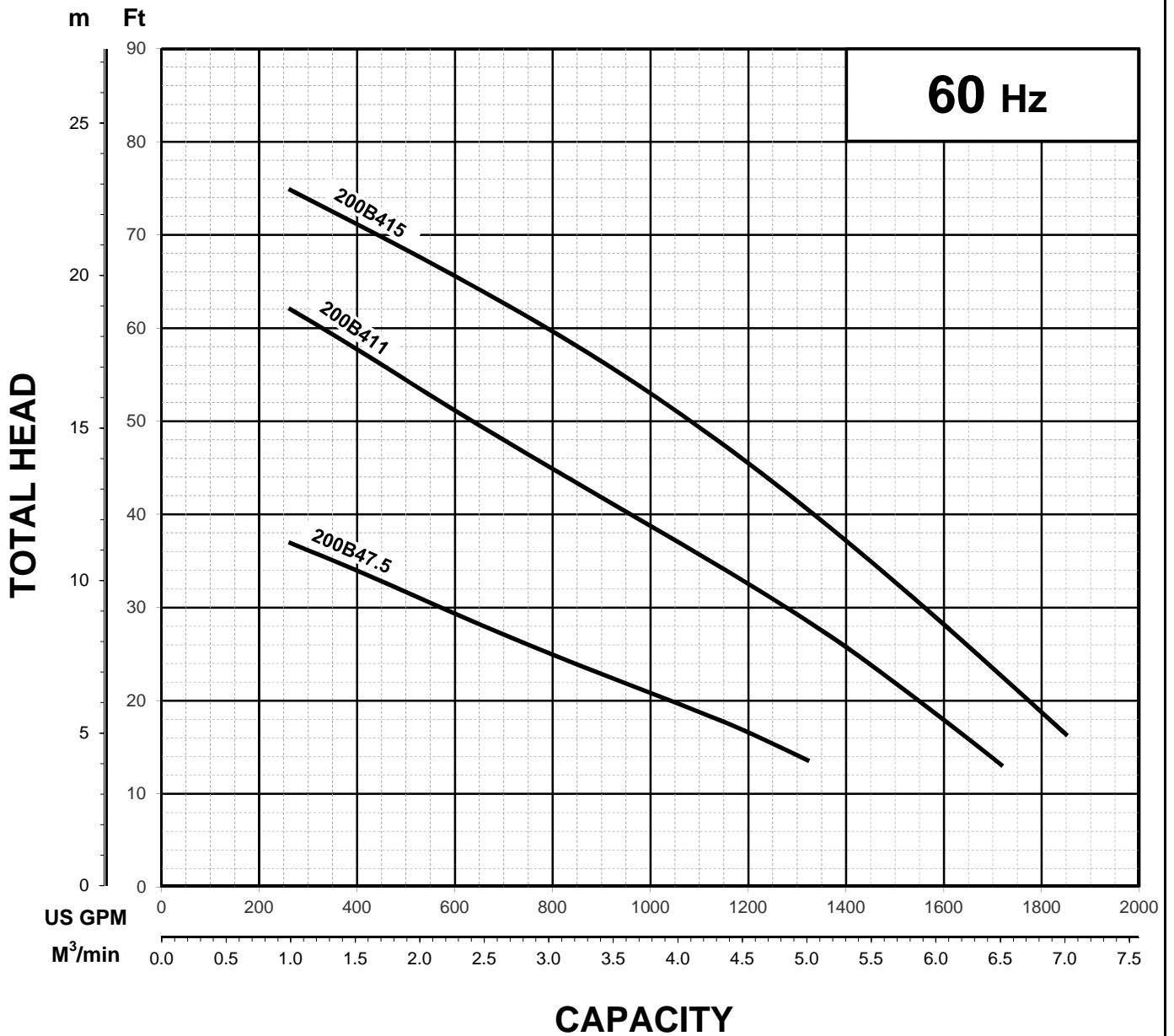

Note



B - SERIES

SEWAGE & WASTEWATER PUMPS

PERFORMANCE
CURVE

MODEL		BORE	HP	KW	RPM	SOLIDS DIA.	LIQUID	SG.	VISCOSITY	TEMP.
(TOS)200B47.5 -66		8"/200mm	10.0	7.5	1735	1.97"/50mm	Water	1.0	1.123cSt.	60°F
PUMP TYPE		PHASE	VOLTAGE		AMPERAGE		HZ	STARTING METHOD		INS. CLASS
Sewage & Wastewater		3	208-230/460/575		29.8-28.0 / 14.0 / ***		60	Direct On Line		F
CURVE No.	DATE	PHASE	VOLTAGE		AMPERAGE		HZ	STARTING METHOD		INS. CLASS
-	-	-	-		-		-	-		-

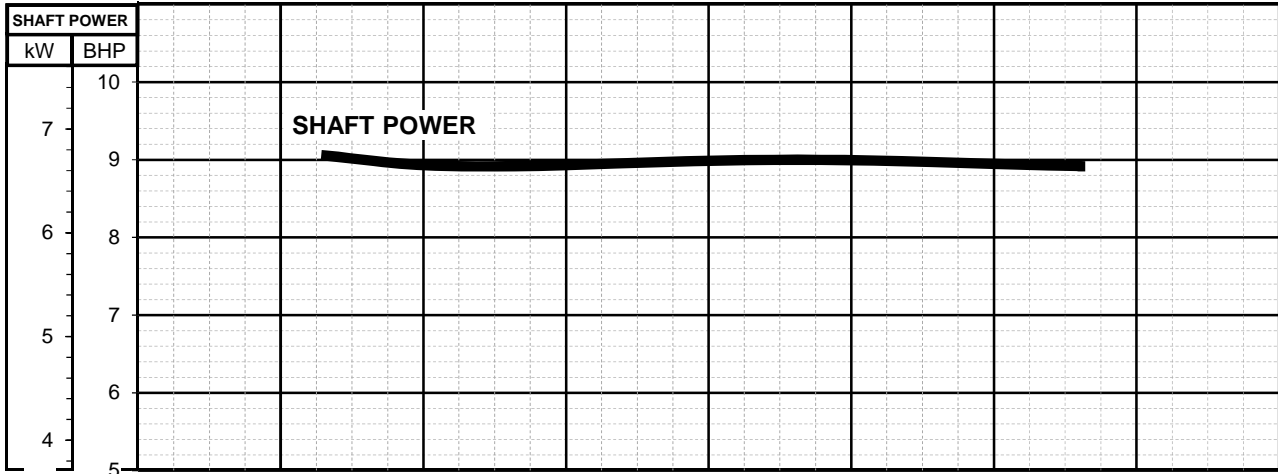
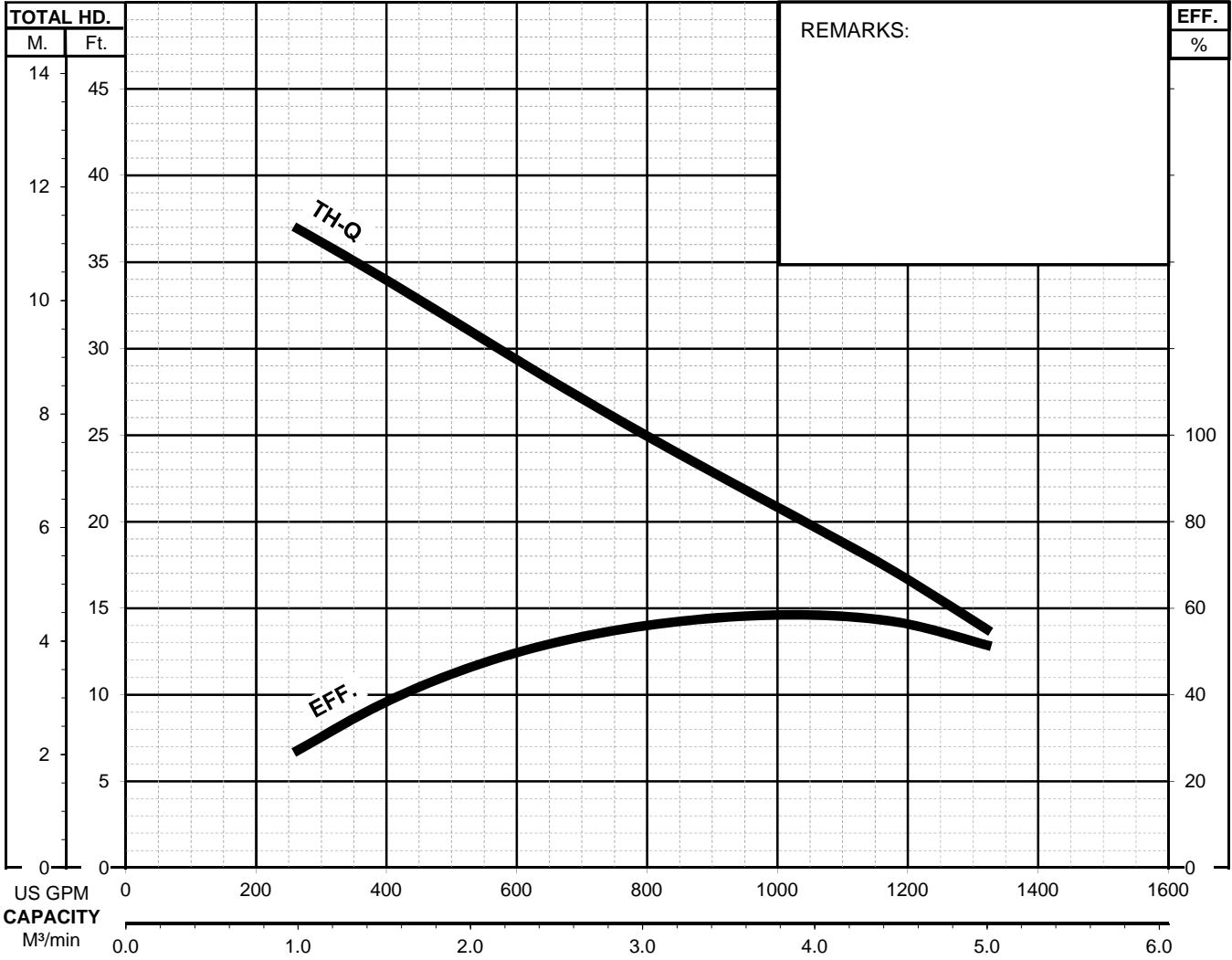



B-SERIES
SEWAGE & WASTEWATER PUMPS

DIMENSIONS

150B47.5L -66
200B47.5 -66

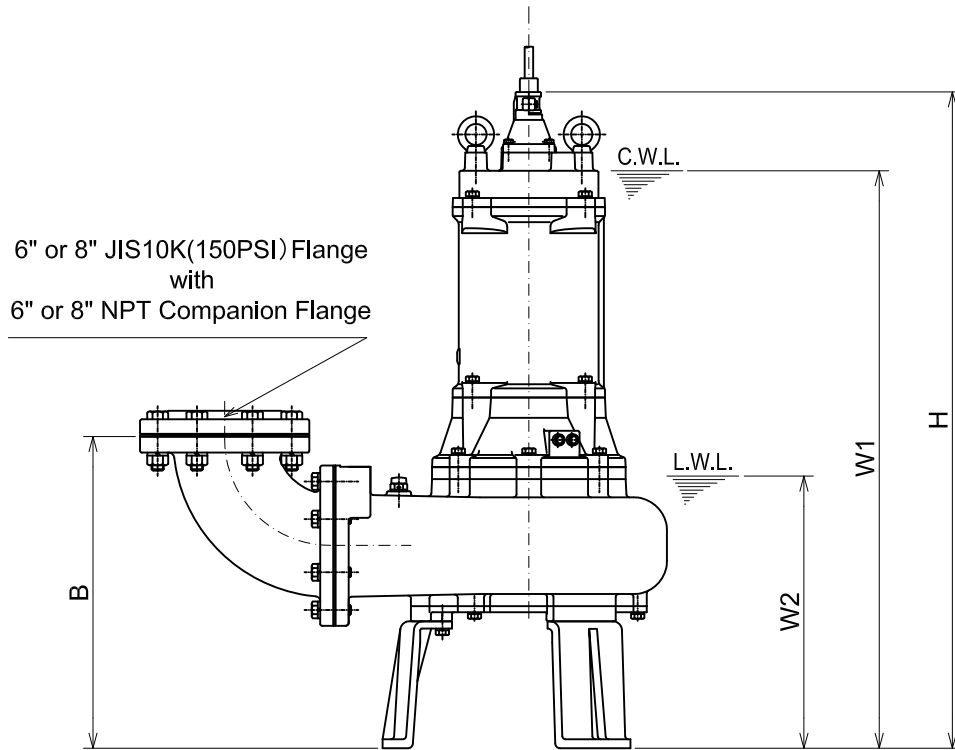
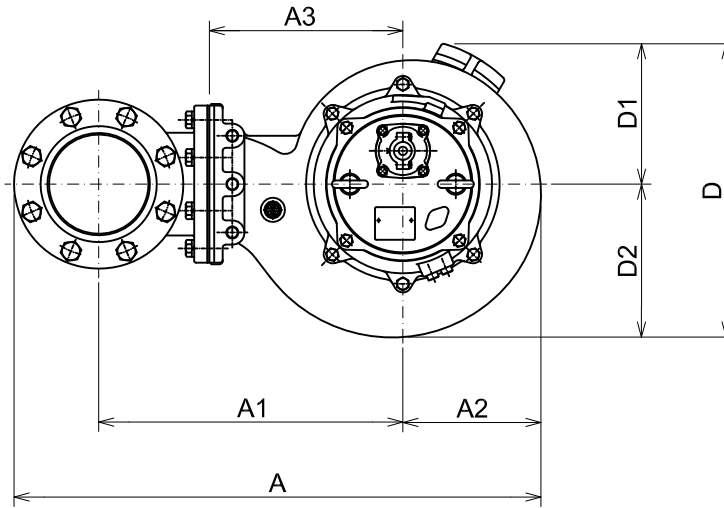

6" or 8" JIS10K(150PSI) Flange with
6" or 8" NPT Companion Flange

C.W.L. :Continuous running Water Level
L.W.L. :Lowest running Water Level

DIMENSIONS:USCS(Inch)

Model	HP	NOM. SIZE	Pump & Motor									C.W.L. W1	L.W.L. W2	Wt. (lbs.)
			A	A1	A2	A3	B	D	D1	D2	H			
150B47.5L -66	10	6"	34 5/16	19 13/16	9	12 5/8	20 1/4	19 1/8	9 1/8	10	42 11/16	37 3/4	17 3/4	408
200B47.5 -66	10	8"	36 7/16	21	9	12 5/8	21 7/16	19 1/8	9 1/8	10	42 11/16	37 3/4	17 3/4	423

*Excluding Cable.

DIMENSIONS:METRIC(mm)

Model	kW	NOM. SIZE	Pump & Motor									C.W.L. W1	L.W.L. W2	Wt. (kg)
			A	A1	A2	A3	B	D	D1	D2	H			
150B47.5L -66	7.5	150	871	503	228	320	515	486	232	254	1085	960	450	185
200B47.5 -66	7.5	200	926	533	228	320	545	486	232	254	1085	960	450	192



**B-SERIES
SEWAGE & WASTEWATER PUMPS**

SECTIONAL VIEW

**150B47.5L -66
200B47.5 -66**

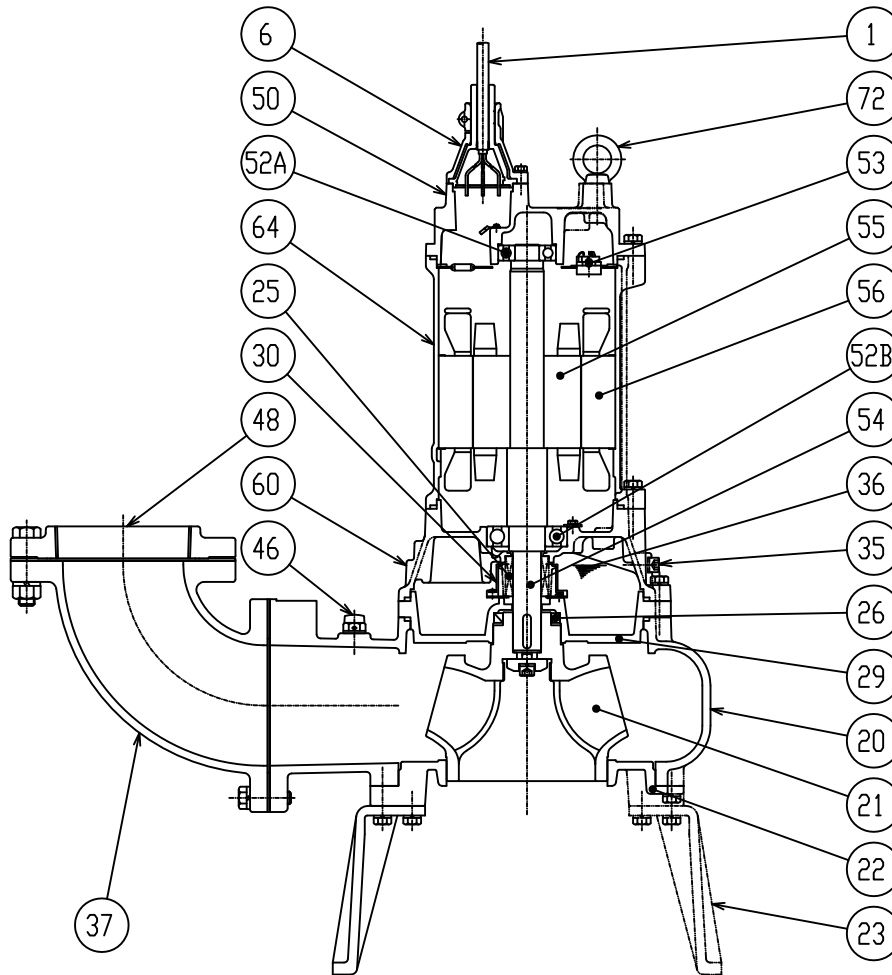

PART#	DESCRIPTION	MAIN MATERIAL / NOTE	RELATED ASTM,AISI CODE	RELATED EN CODE	QTY
1	Power Cable	Chloroprene Sheath AWG 10/4-32ft			1
6	Stuffing Box	Cast Iron	A48M Class30B	EN 1561 GJL-200	1
20	Pump Casing	Cast Iron	A48M Class30B	EN 1561 GJL-200	1
21	Impeller	Cast Iron	A48M Class30B	EN 1561 GJL-200	1
22	Suction Cover	Cast Iron	A48M Class30B	EN 1561 GJL-200	1
23	Pump Stand	Ductile Cast Iron	A536 65-45-12	EN 1563 GJS-450-10	3
25	Mechanical Seal	Silicon Carbide / H-35			1
26	Oil Seal	NBR / TC608212			1
29	Oil Casing	Cast Iron	A48M Class30B	EN 1561 GJL-200	1
30	Oil Lifter	PBT Resin W/GF40			1
35	Oil Plug	Stainless Steel	S 30400	1.4301	2
36	Lubricant	Turbine Oil ISO VG32 or SAE 10W-20			
37	Discharge Bend	Cast Iron	A48M Class30B	EN 1561 GJL-200	1
46	Air Release Valve	Nylon			1
48	Companion Flange	Cast Iron / NPT 6" or 8"	A48M Class30B	EN 1561 GJL-200	1
50	Motor Bracket	Cast Iron	A48M Class30B	EN 1561 GJL-200	1
52A	Upper Bearing	AC-#6306ZZC3			1
52B	Lower Bearing	#6309ZZC3			1
53	Motor Protector				1
54	Shaft	Stainless Steel	S 42000	1.4028	1
55	Rotor				1
56	Stator				1
60	Bearing Housing	Cast Iron	A48M Class30B	EN 1561 GJL-200	1
64	Motor Housing	Cast Iron	A48M Class30B	EN 1561 GJL-200	1
72	Lifting Lug Bolt	Steel	A283 Grade D	EN 10025 S275	2

TSURUMI PUMP
**B - SERIES
SEWAGE & WASTEWATER PUMPS**
**SAMPLE
SPECIFICATIONS**
1. SCOPE OF SUPPLY -

Furnish and install TSURUMI Model _____ Submersible Pump(s). Each unit shall be capable of delivering _____ GPM (_____ m³/min) at _____ Feet (_____ m) TDH. The pump(s) shall be designed to pump waste water, sewage or effluent containing _____ inch (_____ mm) diameter solids without damage during operation. The pump(s) shall be designed so that the shaft power required (BHP)/(kW) shall not exceed the motor rated output throughout the entire operating range of the pump performance curve. The pump discharge size shall Be _____ inch, (_____ mm).

2. MATERIALS OF CONSTRUCTION -

Construction of major parts of the pumping unit(s) including pump casing, impeller, and discharge elbow shall be manufactured from gray cast iron, ASTM A48 CLASS 30B. Unit(s) shall have a field adjustable and or replaceable, cast iron shear type wear plate or wear rings. Internal and external surfaces coming into contact with the pumpage shall be protected by a fused polymer coating. All exposed fasteners shall be stainless steel. All units shall be furnished with a discharge elbow with 150 lb. (10 kg/cm²) ANSI flange or flat face flange and NPT companion flange. Impellers shall be of the solids handling design and shall be slip fit to the shaft and key driven. The pump casing shall incorporate an air relief valve.

3. MECHANICAL SEAL -

All units shall be furnished with a dual inside mechanical shaft seal located completely out of the pumpage, running in a separate oil filled chamber and further protected by an exclusionary oil seal located between the bottom seal faces and the fluid being pumped. All units shall be fitted with a device that shall provide positive lubrication of top mechanical seal, (down to one third of the standard oil level). The device shall not consume any additional electrical power. Mechanical seals shall rated to preclude the incursion of water up to 42.6 PSI. (98.4 Ft.), 56.8 PSI.(131.2 Ft.), 71.1 PSI.(164.0 Ft.). Units shall have silicon carbide mechanical seal faces. Mechanical seal hardware shall be stainless steel.

4. MOTOR -

The pump motor(s) shall be _____ Hp., _____ kW., _____ V., 60 Hz., _____ Phase and shall be NEMA MG-1, Design Type B equivalent. Motor(s) shall be rated at _____ full load amps. Motor(s) shall have a 1.15 service factor and shall be rated for 10(1 Hp.), 5-6(2 to 5 Hp.), 3-4(7.5 to 20 Hp.), and 2-3(30 Hp. and above) starts per hour. Motor(s) shall be air filled, copper wound, class E, B, or F insulated with built in thermal protection for each winding. Motor shaft shall be 420 or 403 stainless steel and shall be supported by two permanently lubricated, high temperature ball bearings, with a B-10 life rating at best efficiency point of 60,000 hours. On units up to 10 Hp. (7.5 kW), the bottom bearing shall be single row, double shielded, C3, deep groove type ball bearings. On units 15 Hp. (11 kW) and above, the bottom bearing shall be two row, double shielded, C3, deep groove type ball bearings. The top bearing on all units shall be single row, double shielded, C3, deep groove type ball bearings. Motor housing and bearing housing shall be gray cast iron, ASTM A48 CLASS 25B or 30B(150B63.7, 7.5 Hp. and above). Motors shall be D.O.L. or Star-delta start (15 Hp. and above), and shall be suitable for across the line start or variable speed applications, utilizing a properly sized variable frequency drive.

5. POWER CABLE AND CABLE ENTRANCE -

The pump power cable shall be suitable for submersible pump applications. Units up to 5 Hp., (except 150B63.7) shall be supplied with a cable entrance that incorporates built in strain relief, a one piece, three way mechanical compression seal with a fatigue reducing cable boot. On units 7.5 Hp. and above, and 150B63.7, the cable entrance shall incorporate built in strain relief, and combination three way mechanical compression sealing with a fatigue reducing/thermal expansion rubber boot. The power cable shall be field replaceable utilizing standard submersible pump cable. The cable entrance assembly on all units shall contain an anti-wicking block to eliminate water incursion into the motor due to capillary wicking should the power cable be accidentally Damaged.