



**KTZ- SERIES
DEWATERING PUMP**

SPECIFICATIONS

■ FEATURES

1. Semi-open, high chrome iron impeller with ductile iron wear plate increases wear resistance when pumpage contains abrasive particles.
2. Double inside mechanical seals with silicon carbide faces, running in an oil filled chamber and further protected by a lip seal running against a replaceable, 430 stainless steel shaft sleeve, provides for the most durable seal design available.
3. Highly efficient, continuous duty air filled, copper wound motor with class F insulation minimizes the cost of operation.
4. Built in thermal & amperage sensing protector prevents motor failure due to single Phasing,

overloading or accidental run -dry conditions.

5. Double shielded, permanently lubricated, high temperature C3 ball bearings, rated for a B-10 life of 60,000 hours, extend operational life.
6. Top discharge, flow-thru design enables operation at low water levels for extended periods.

■ APPLICATIONS

1. Commercial, industrial wastewater and construction site drainage.
2. Effluent transfer.
3. Decorative waterfalls and fountains.
4. Raw water supply from rivers or lakes..



■ SPECIFICATIONS

- Discharge Size
- Horsepower Range
- Performance Range Capacity Head
- Maximum water temperature
- Materials of Construction
 - Casing
 - Impeller
 - Shaft
 - Motor Frame
 - Fasteners
- Seal Pressure Relief Ports
- Mechanical Seal
 - Elastomers
- Impeller Type
- Solids Handling Capability
- Motor Nomenclature
 - Type, Speed, Hz.
 - Voltage, Phase
 - Insulation
 - Bearings
- Accessories
- Operational Mode

■ STANDARD

- 2 ~ 4" NPT (50 - 100 mm)
- 6" is Optional (KTZ67.5 / KTZ611)
- 2 ~ 15 HP. (1.5 ~ 11 kW)
- 33.0 ~ 645.0 GPM. (0.13 ~ 2.44 m³/min)
- 13.1 ~ 167.0 Ft. (4.0 ~ 50.9 m)
- 104° F. (40° C.)
- Cast Iron
- High Chrome Iron
- 420 Stainless Steel
- Cast Iron
- 304 Stainless Steel
- 10 - 15HP (7.5 - 11kW)
- Silicon Carbide
- NBR (Nitrile Butadiene Rubber)
- Semi-open, solids handling.
- 0.334 - 0.787" (8.5 - 20.0mm)
- Air Filled, 3600 RPM, 60 Hz.
- 208/230/460/575 V., 3 Phase
- Class F
- Pre-lubricated, Double Shielded
- Submersible Power Cable 50' (15.0m)
- Manual

■ OPTIONS

Length as Required



TSURUMI PUMP

**KTZ - SERIES
DEWATERING PUMPS**

**PERFORMANCE
RANGE**

GROUP PERFORMANCE RANGE

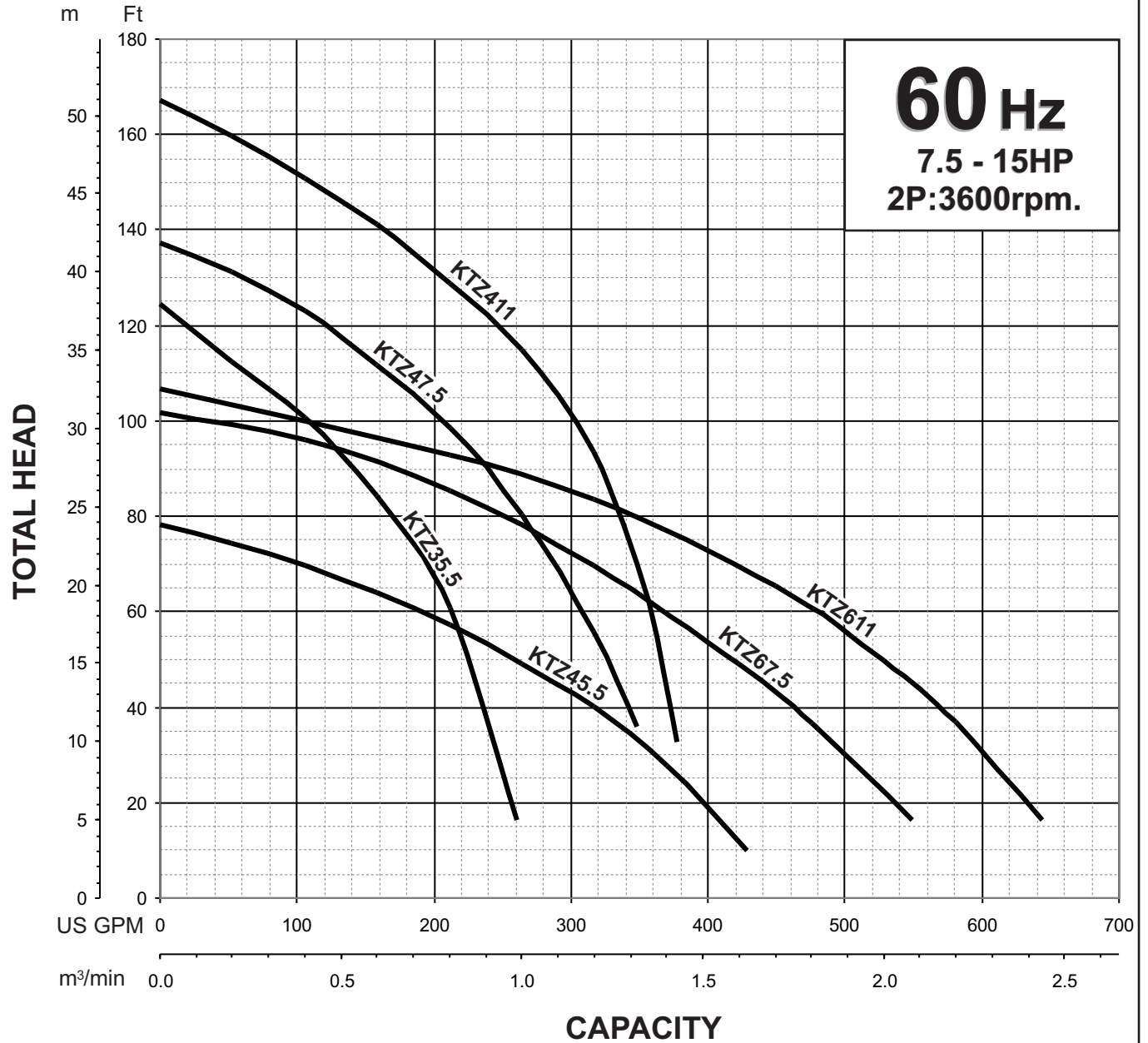



KTZ - SERIES DEWATERING PUMPS

PERFORMANCE CURVE

MODEL	BORE	HP	KW	RPM	SOLIDS DIA	LIQUID	SG.	VISCOSITY	TEMP.
KTZ611-63	4"/100mm	15	11	3520	0.787"/20mm	Water	1.0	1.123 cSt.	60°F
PUMP TYPE	PHASE	VOLTAGE	AMPERAGE		HZ	STARTING METHOD	INS. CLASS		
Dewatering Pump	3	208-230/460/575	39.8-37.4 / 18.6 / 14.9		60	Direct On Line	F		
CURVE No.	DATE	PHASE	VOLTAGE	AMPERAGE	HZ	STARTING METHOD	INS. CLASS		
-	-	-	-	-	-	-	-		

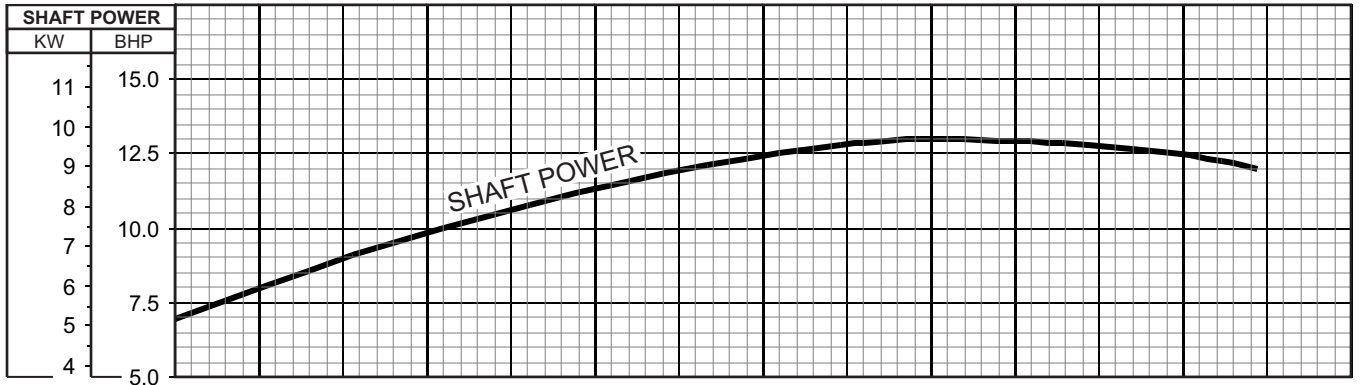
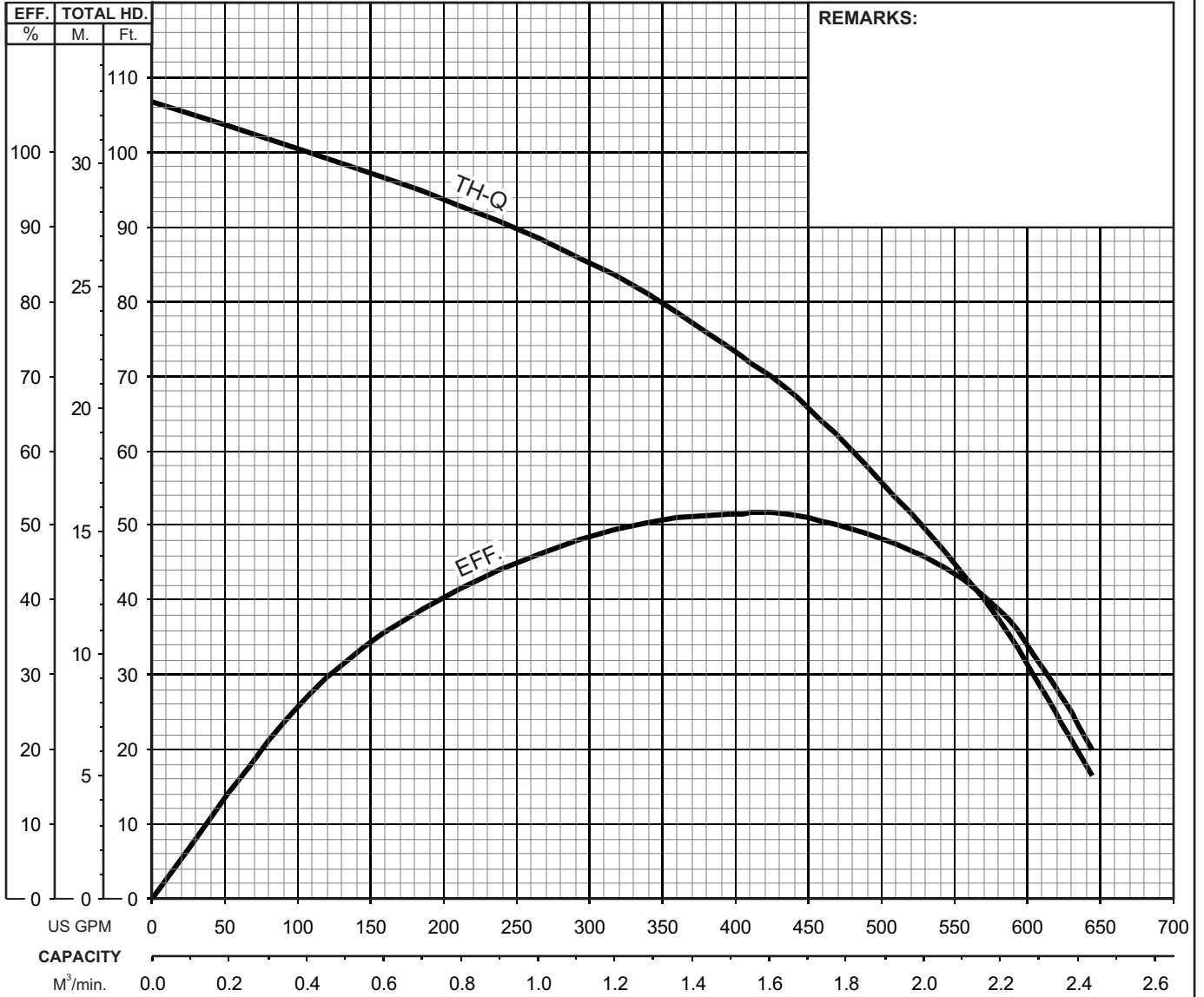



**KTZ - SERIES
DEWATERING PUMPS**

DIMENSIONS

**KTZ411-63
KTZ611-63**

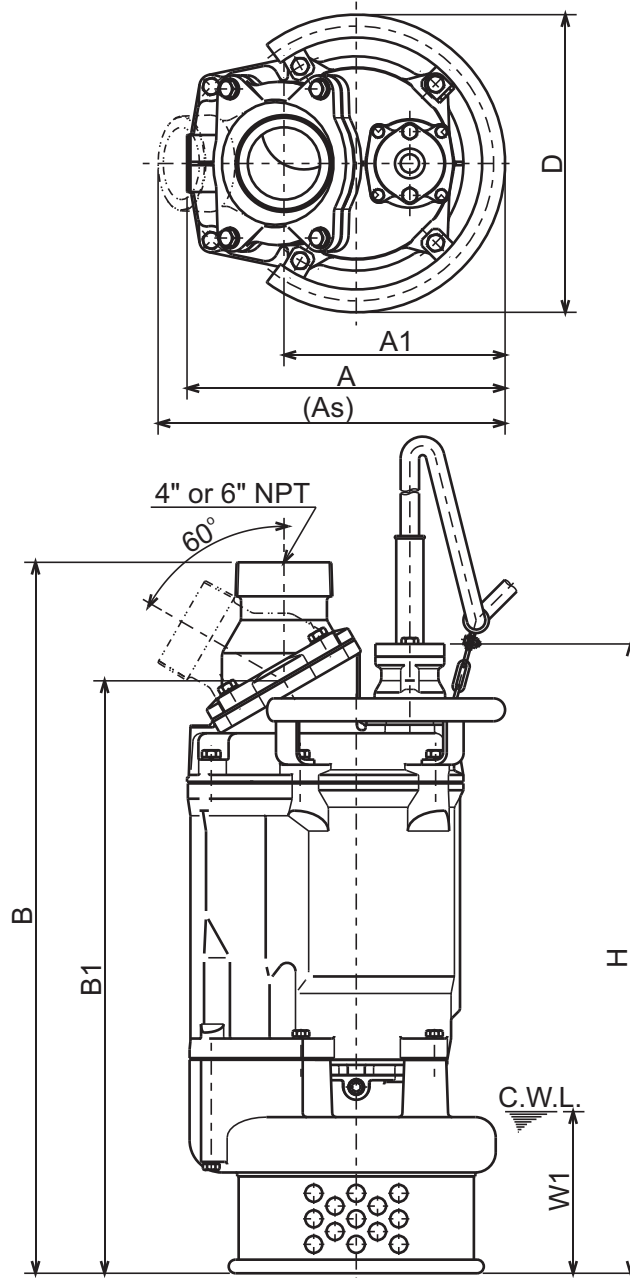

C.W.L. : Continuous running Water Level

DIMENSIONS:USCS (Inch)

Model	HP	NOM. SIZE	Pump & Motor							C.W.L. W1	Wt. (lbs.)
			A	As	A1	B	B1	D	H		
KTZ411-63	15	4"	14 3/4	16 1/16	10 1/4	32 15/16	27 7/16	13 3/4	29 1/8	7 1/2	293
KTZ611-63(4")	15	4"	14 3/4	16 1/16	10 1/4	32 15/16	27 7/16	13 3/4	29 1/8	7 1/2	295
KTZ611-63	15	6"	14 3/4	17 1/4	10 1/4	33 11/16	27 7/16	13 3/4	29 1/8	7 1/2	295

DIMENSIONS:METRIC (mm)

Model	kW	NOM. SIZE	Pump & Motor							C.W.L. W1	Wt. (kg)
			A	As	A1	B	B1	D	H		
KTZ411-63	11	100	374	408	260	836	697	350	740	190	133
KTZ611-63(4")	11	100	374	408	260	836	697	350	740	190	134
KTZ611-63	11	150	374	439	260	856	697	350	740	190	134

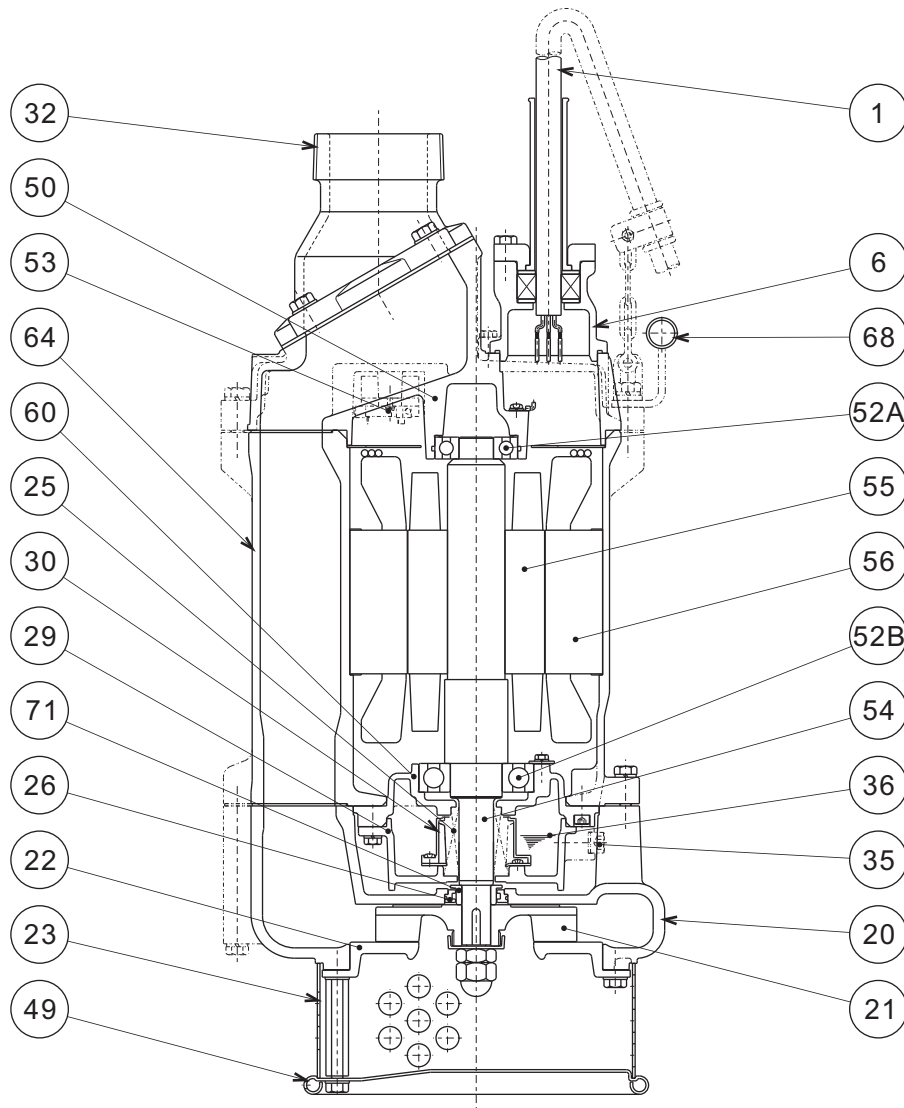
TSURUMI PUMP
**KTZ - SERIES
DEWATERING PUMPS**
SECTIONAL VIEW
**KTZ411-63
KTZ611-63**

ITEM#	DESCRIPTION	MAIN MATERIAL / NOTE	RELATED ASTM, AISI CODE	RELATED EN CODE	Q'TY
1	Power Cable	Chloroprene Sheath AWG8/4-50ft			1
6	Stuffing Box	Cast Iron	A48M Class30B	EN 1561 GJL-200	1
20	Pump Casing	Cast Iron	A48M Class30B	EN 1561 GJL-200	1
21	Impeller	High Chrome Cast Iron	A532 Class III Type A	DIN 1695 G-X260Cr27	1
22	Suction Cover	Ductile Cast Iron	A536 80-55-06	EN 1563 GJS-500-7	1
23	Suction Strainer	Steel (Cold Rolled)	A109/A1008	EN 10130	1
25	Mechanical Seal	Silicon Carbide / H-30T			1
30	Oil Lifter	PBT Resin			1
26	Labyrinth Ring	Stainless Steel	S 30400	1.4301	1
32	Discharge Connection	Cast Iron / NPT 4" (or 6")	A48M Class30B	EN 1561 GJL-200	1
35	Oil Plug	Stainless Steel	S 30400	1.4301	1
36	Lubricant	Turbine Oil ISO VG32 or SAE10W-20			
49	Bottom Plate	Steel (Cold Rolled)	A109/A1008	EN 10130	1
50	Motor Head Cover	Cast Iron	A48M Class30B	EN 1561 GJL-200	1
52A	Upper Bearing	#6306ZXC3			1
52B	Lower Bearing	#6309ZXC3			1
53	Motor Protector				1
54	Shaft	Stainless Steel	S 42000	1.4028	1
55	Rotor				1
56	Stator				1
60	Bearing Housing	Cast Iron	A48M Class25B	EN 1561 GJL-150	1
64	Motor Housing	Cast Iron	A48M Class30B or 25B	EN 1561 GJL-200 or GJL-150	1
68	Handle	Carbon Steel Pipe + Steel	A53 Type F + A283 Grade D	DIN 1615 St33 + EN 10025 S275	1
71	Shaft Sleeve	Stainless Steel	S 40300	1.4000	1

TSURUMI PUMP
**KTZ - SERIES
DEWATERING PUMPS**
**SAMPLE
SPECIFICATIONS**

1. SCOPE OF SUPPLY -

Furnish and install TSURUMI Model _____ Submersible Pump(s). Each unit shall be capable of delivering _____ GPM (_____ m³/min) at _____ Feet (_____ m) TDH. The pump(s) shall be designed to pump waste water, without damage during operation. The pump(s) shall be designed so that the shaft power required (BHP)/(kW) shall not exceed the motor rated output throughout the entire operating range of the pump performance curve. Pump(s) shall be of the top discharge, flow through design.

2. MATERIALS OF CONSTRUCTION -

Construction of major parts of the pumping unit(s) shall be as follows: Pump casing shall be gray cast iron, ASTM A48 CLASS 30B. Motor frame shall be gray cast iron, ASTM A48 CLASS 25B. Field adjustable/replaceable, wear plate shall be ductile cast iron. Impellers shall be of the multi-vane semi-open design and shall be high chrome cast iron. Impellers shall be equipped with back pump out vanes, slip fit to the shaft and key driven. Internal and external surfaces coming into contact with the pumpage shall be protected by a fused polymer coating. All exposed fasteners shall be stainless steel. All units shall be furnished with _____" NPT discharge connector.

3. MECHANICAL SEAL -

All units shall be furnished with a dual inside mechanical shaft seal located completely out of the pumpage, running in a separate oil filled chamber and further protected by an exclusionary oil seal located between the bottom seal faces and the fluid being pumped. The oil chamber shall be fitted with a device that shall provide positive lubrication of the top mechanical seal, (down to one third of the standard oil level). The device shall not consume any additional electrical power. Mechanical seals shall be rated to preclude the incursion of water up to 42.6 PSI (98.4 Ft.) submergence. Units shall have silicon carbide mechanical seal faces. Mechanical seal hardware shall be stainless steel.

4. MOTOR-

The pump motor(s) shall be _____ HP., _____ kW., _____ V., 60 Hz. 3 Phase and shall be NEMA MG-1, Design Type B equivalent. Motor(s) shall be rated at _____ full load amps. Motor(s) shall have a 1.15 service factor and shall be rated for 20 starts per hour. Motor(s) shall be air filled, copper wound, class F insulated with built in thermal and over amperage protection for each winding. Motor shaft shall be 420 stainless steel, fitted with a replaceable 304(2 and 3 Hp.) or 403(10 and 15 Hp.) stainless steel shaft sleeve and shall be supported by two permanently lubricated, high temperature ball bearings, with a B-10 life rating at best efficiency point of 60,000 hours. Bearings on all units shall be single row, double shielded, C3, deep groove type ball bearing. Motors shall be suitable for across the line start or variable speed applications, utilizing a properly sized variable frequency drive.

5. POWER CABLE AND CABLE ENTRANCE -

Units up to 3 HP shall be supplied with a cable entrance that incorporates built in strain relief, a one piece, three way mechanical compression seal and a fatigue reducing cable boot. The pump power cable shall be suitable for submersible pump applications. The power cable on units 5 Hp and above shall be field replaceable utilizing standard submersible pump cable. The cable entrance shall incorporate built in strain relief and a combination three way mechanical compression sealing with a fatigue reducing boot. The cable entrance assembly shall contain an anti-wicking block to eliminate water incursion into the motor due to capillary wicking should the power cable be accidentally damaged.