



**B - SERIES
SEWAGE & WASTEWATER PUMPS**

SPECIFICATIONS

■ FEATURES

1. Semi-open, Single vane, impellers with field adjustable /replaceable shear plate and, Enclosed Multi-vane, impellers, with field adjustable / replaceable wear plate provides for high wear resistance and enhanced solids handling capability.
2. Highly efficient, continuous duty air filled, copper wound motor with class E, B, F insulation minimizes the cost of operation.
3. Built in thermal protection prevents motor failure due to overloading, accidental run-dry and single phasing in three phase units.
4. Double inside mechanical seals with silicon carbide faces, running in an oil filled chamber, equipped with an oil lifter,, and further protected by an exclusionary oil Seal(s), provides for the most -

- durable seal design available.

5. Double shielded, permanently lubricated, high temperature C3 ball bearings rated for a B-10 life of 60,000 hours provide for extended operational life.

■ APPLICATIONS

1. Commercial, Industrial sewage, wastewater, or effluent transfer.
2. Decorative fountains and aquiculture .
3. Raw water supply from rivers or lakes.

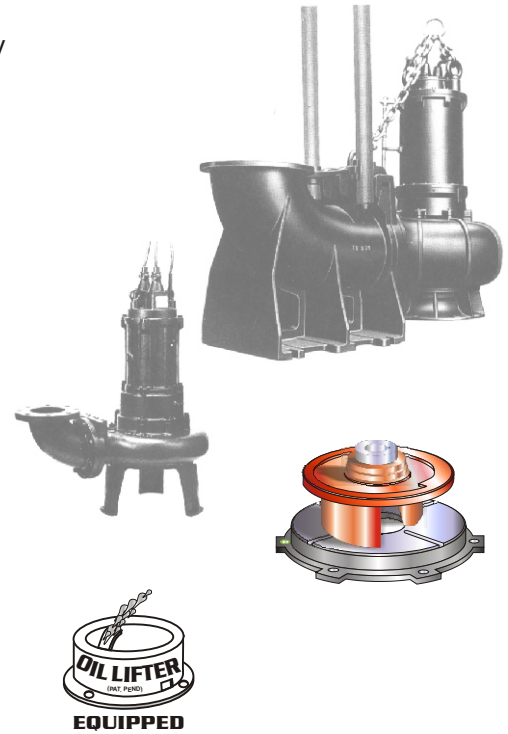

■ SPECIFICATIONS

- Discharge Size
- Horsepower Range
- Performance Range, Capacity Head
- Maximum water temperature
- Materials of Construction
 - Casing
 - Impeller
 - Shaft
 - Motor Frame
 - Fasteners
- Mechanical Seal
 - Elastomers
- Impeller Type
- Solids Handling Capability
- Bearings
- Motor Nomenclature
 - Type, Speed, Hz.
- Voltage, Phase
- Insulation
- Accessories
- Operational Mode

■ STANDARD

- 2" ~ 8" (50 ~ 200 mm)
- 1 Hp. ~ 20 Hp. (.75 kW ~ 20 kW)
- 20 ~ 1850 G.P.M. (.08 ~ 7.00 m³/min)
- 8.2 Ft.~105.0 Ft. (2.5 ~ 32.0m)
- 104° F. (40° C.)
- Cast Iron, ASTM 48 Class 35
- Cast Iron, ASTM 48 Class 35
- 403,420 Stainless Steel
- Cast Iron, ASTM 48 Class 30
- 304 Stainless Steel
- Silicon Carbide
- NBR (Nitril Buna Rubber)
- Semi-open, Enclosed, solids handling.
- .79" ~ 2.95" (20 ~ 75 mm)
- Pre-lubricated, Double Shielded
- Air Filled,
- 3600, 1800 & 1200 Rpm, 60 Hz.
- 115 or 230 (1Phase)
- 208-230, 460 or 575 V., (3 Phase)
- Class E, B, F
- Submersible Power Cable 32' (10 m)
- Manual

■ OPTIONS

- Dry-Pit
- Nema 3R inverter available for 230 V., 1 Ph. operation from 2~5 Hp.
- Length as required.
- TO/TOS Slide Rail System

GROUP PERFORMANCE RANGE

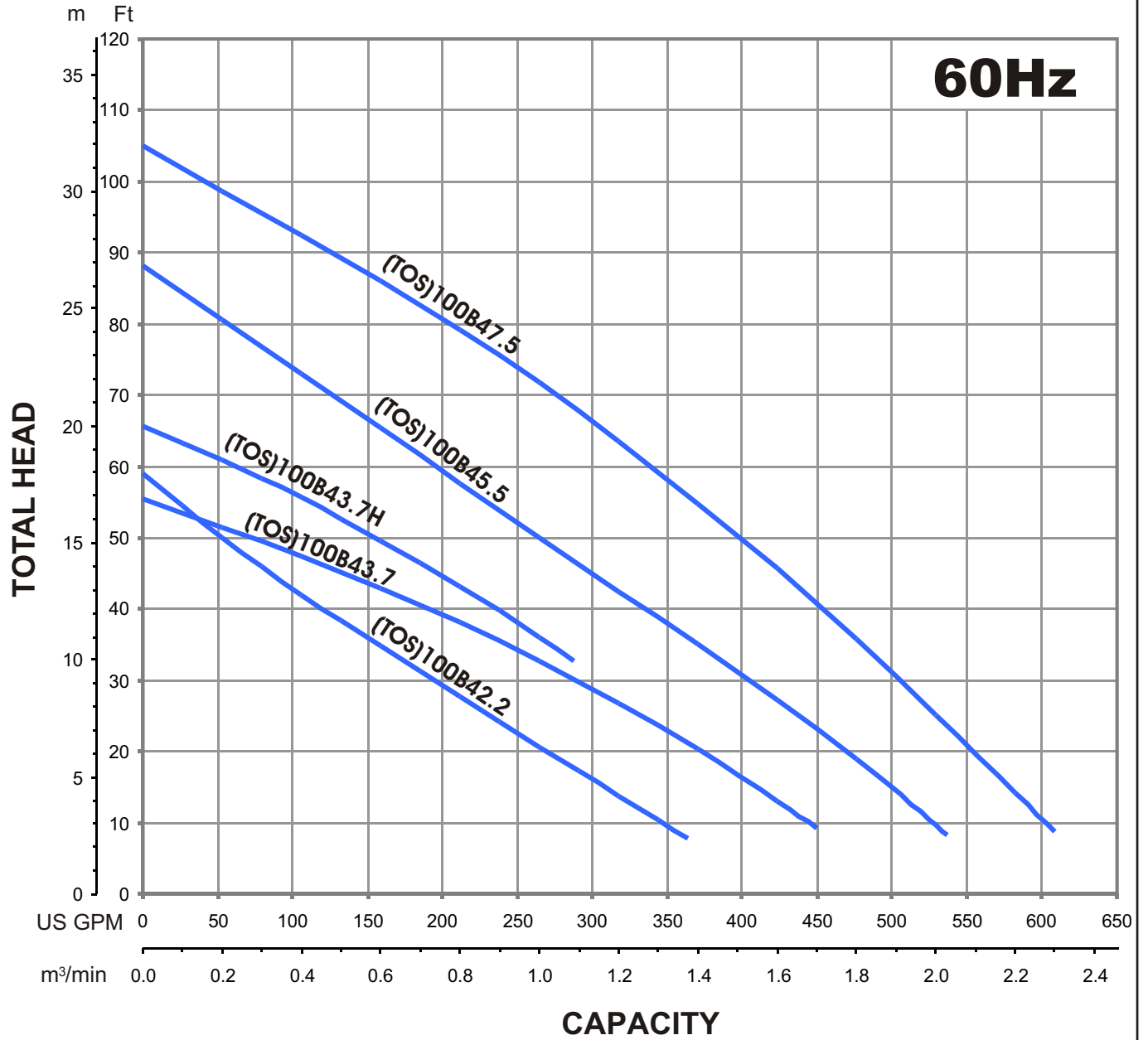



B-SERIES
SEWAGE & WASTEWATER PUMPS

PERFORMANCE
CURVE

MODEL	BORE	HP	KW	RPM	SOLIDS DIA.	LIQUID	SG.	VISCOSITY	TEMP.
(TOS)100B43.7 -62	4"/100mm	5	3.7	1690	1.77"/45mm	Water	1.0	1.123cSt.	60°F
PUMP TYPE	PHASE	VOLTAGE	AMPERAGE	HZ	STARTING METHOD	INS.CLASS			
Sewage&Wastewater	3	230/460/575	13.8/6.9/5.4	60	Direct On Line	E			
CURVE No.	DATE	PHASE	VOLTAGE	AMPERAGE	HZ	STARTING METHOD	INS.CLASS		
-	-	-	-	-	-	-	-		

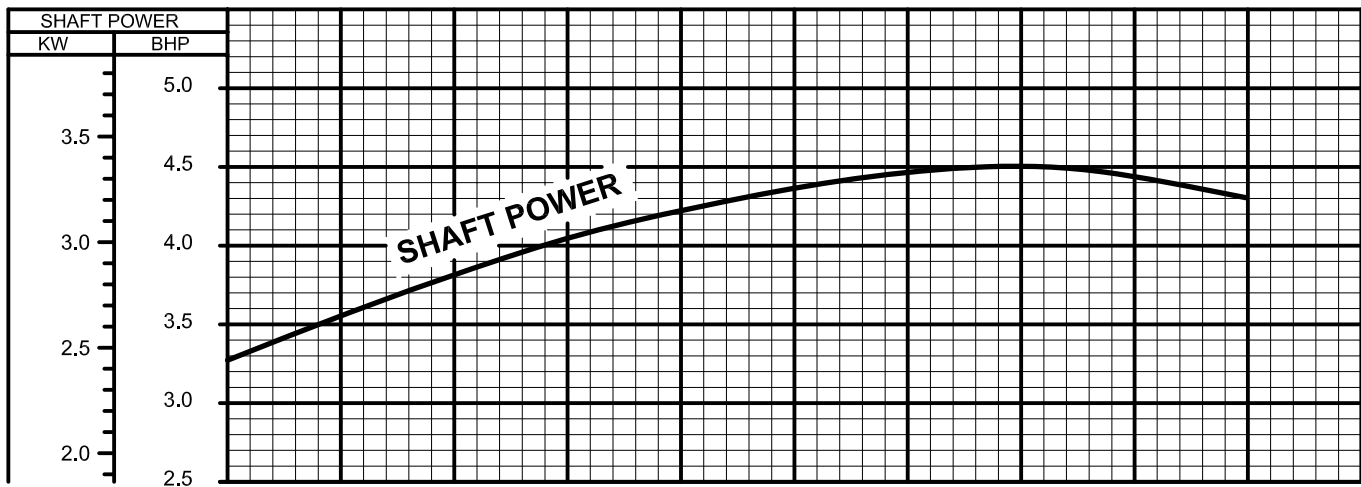
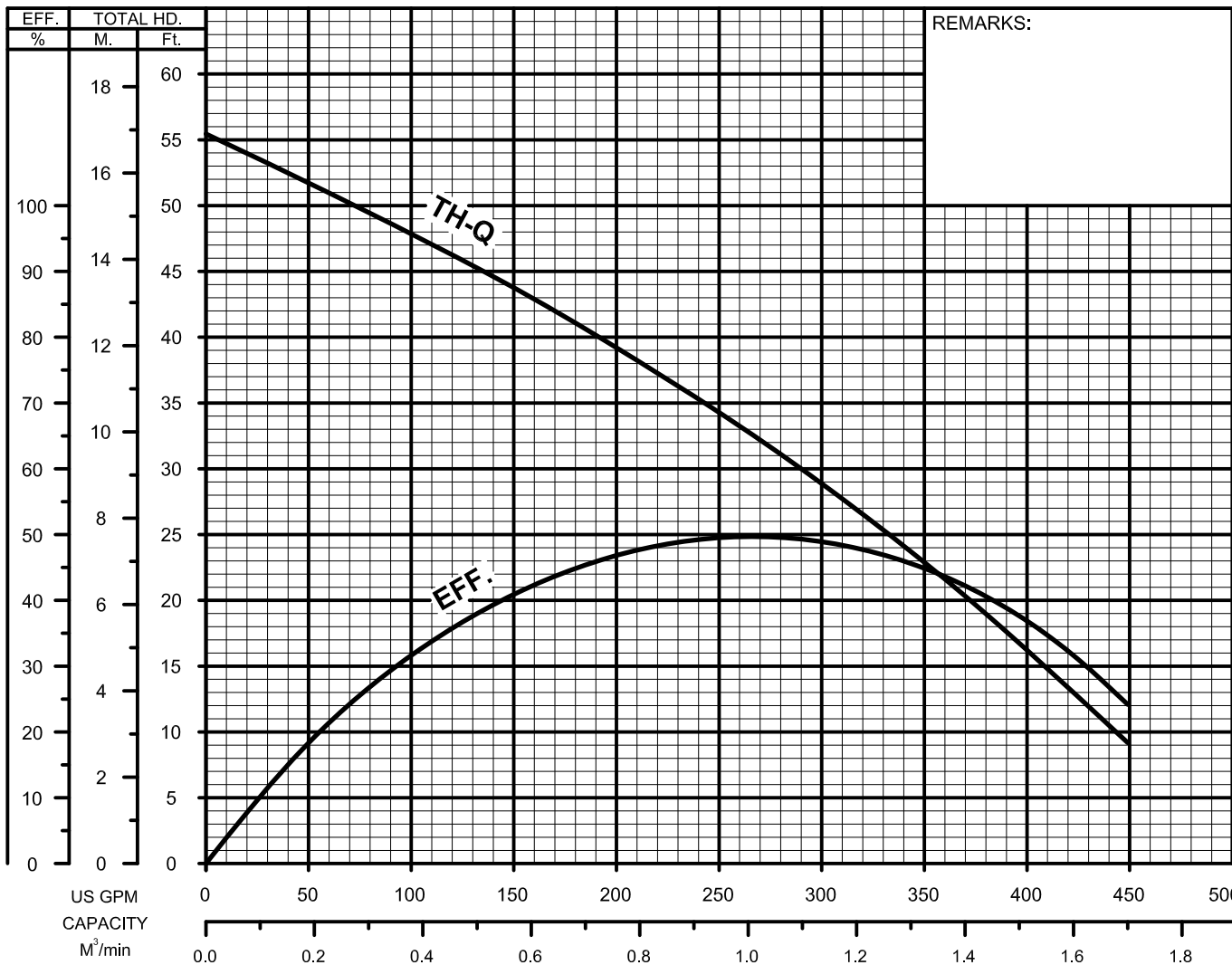



B-SERIES
SEWAGE & WASTEWATER PUMPS

DIMENSIONS

100B42.2 -62 (3"Dis.)
100B43.7 -62 (3"Dis.)
100B43.7H -63 (3"Dis.)

Bend model:
BEND80-80 ANSI

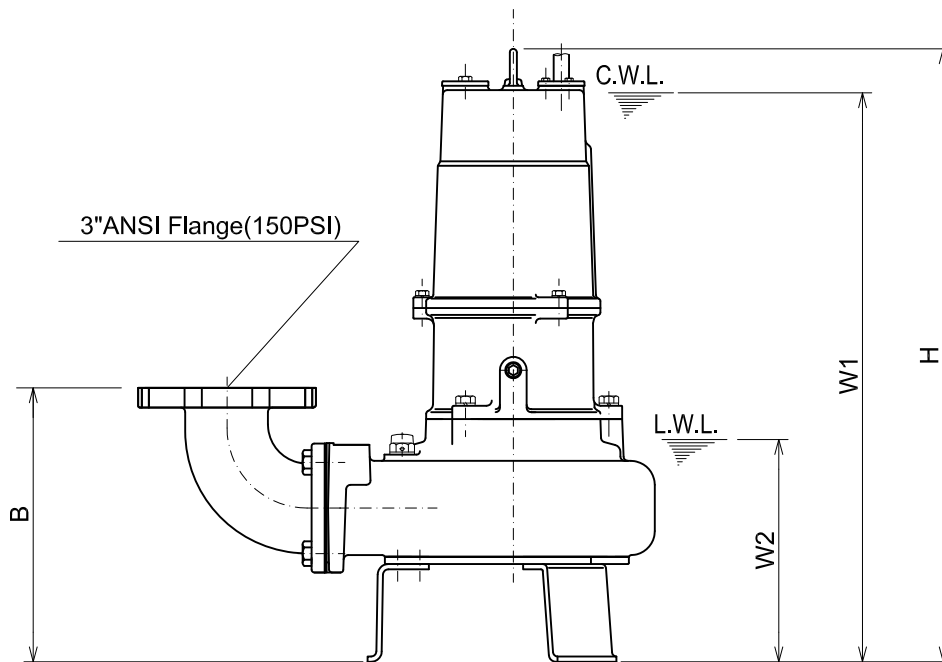
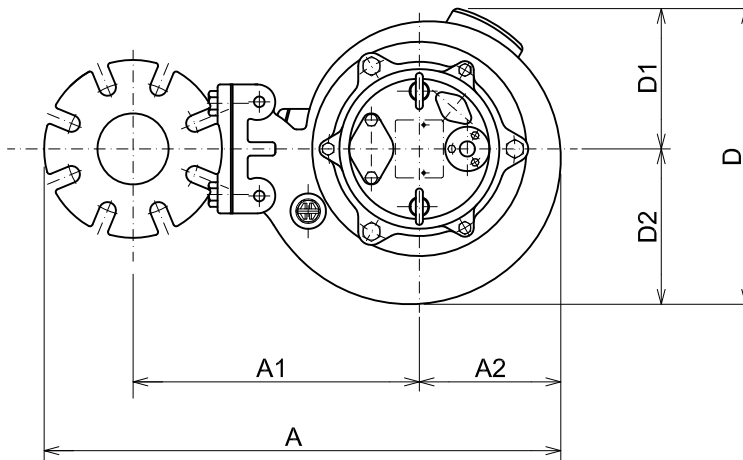

C.W.L. :Continuous running Water Level
L.W.L. :Lowest running Water Level

DIMENSIONS:USCS(Inch)

Model	HP	NOM. SIZE	Pump & Motor								C.W.L.	L.W.L.	*Wt. (lbs.)
			A	A1	A2	B	D	D1	D2	H			
100B42.2 -62	3	3"	23 1/16	13 1/16	6 1/16	11 15/16	12 3/4	6 1/4	6 9/16	24 1/4	22 1/2	8 7/8	146
100B43.7 -62	5	3"	23 5/16	13 1/16	6 1/4	12 3/16	13 1/8	6 1/4	6 7/8	27 3/16	25 3/8	9 1/4	181
100B43.7H -63	5	3"	23 3/8	13 1/16	6 5/16	11 15/16	13 9/16	6 5/8	6 7/8	26 1/4	24 3/8	8 7/8	176

DIMENSIONS:METRIC(mm)

Model	kW	NOM. SIZE	Pump & Motor								C.W.L.	L.W.L.	*Wt. (kg)
			A	A1	A2	B	D	D1	D2	H			
100B42.2 -62	2.2	80	586	332	154	304	324	158	166	616	570	225	66
100B43.7 -62	3.7	80	592	332	159	309	333	158	175	690	645	235	82
100B43.7H -63	3.7	80	593	332	161	304	344	169	175	666	620	225	80

*Excluding Cable.

<b style="font-size: 1.2em;">TSURUMI PUMP	<b style="font-size: 1.2em;">B-SERIES SEWAGE & WASTEWATER PUMPS	<b style="font-size: 1.2em;">DIMENSIONS
---	---	---

100B42.2 -62
100B43.7 -62
100B43.7H -63

Bend model:
BEND80-100 ANSI

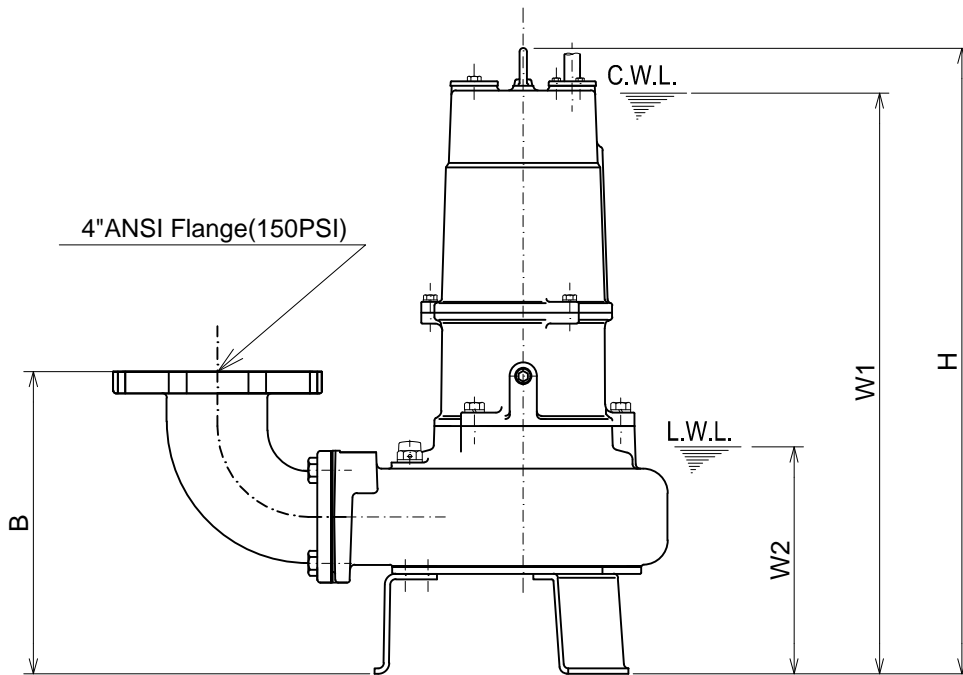
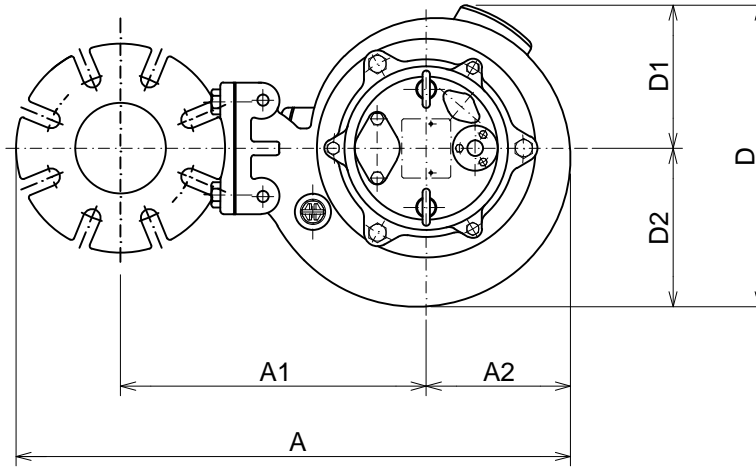

C.W.L. :Continuous running Water Level
L.W.L. :Lowest running Water Level

DIMENSIONS:USCS(Inch)

Model	HP	NOM. SIZE	Pump & Motor								C.W.L. W1	L.W.L. W2	*Wt. (lbs.)
			A	A1	A2	B	D	D1	D2	H			
100B42.2 -62	3	4"	24 7/16	13 11/16	6 1/16	12 15/16	13 1/16	6 7/16	6 9/16	24 1/4	22 1/2	8 7/8	148
100B43.7 -62	5	4"	24 11/16	13 11/16	6 5/16	13 1/8	13 3/8	6 7/16	6 7/8	27 3/16	25 3/8	9 1/4	183
100B43.7H -63	5	4"	24 11/16	13 11/16	6 5/16	12 15/16	13 9/16	6 5/8	6 7/8	26 1/4	24 3/8	8 7/8	177

DIMENSIONS:METRIC(mm)

*Excluding Cable.

Model	kW	NOM. SIZE	Pump & Motor								C.W.L. W1	L.W.L. W2	*Wt. (kg)
			A	A1	A2	B	D	D1	D2	H			
100B42.2 -62	2.2	100	616	347	154	328	331	164	167	616	570	225	67
100B43.7 -62	3.7	100	622	347	160	333	339	164	175	690	645	235	83
100B43.7H -63	3.7	100	622	347	160	328	344	169	175	666	620	225	80



B-SERIES
SEWAGE & WASTEWATER PUMPS

DIMENSIONS

Guide Rail System
Model : TOS3-80-80 ANSI
Wt. : 64lb.(29kg)

TOS100B42.2 -62 (3"Dis.)
TOS100B43.7 -62 (3"Dis.)
TOS100B43.7H -63 (3"Dis.)

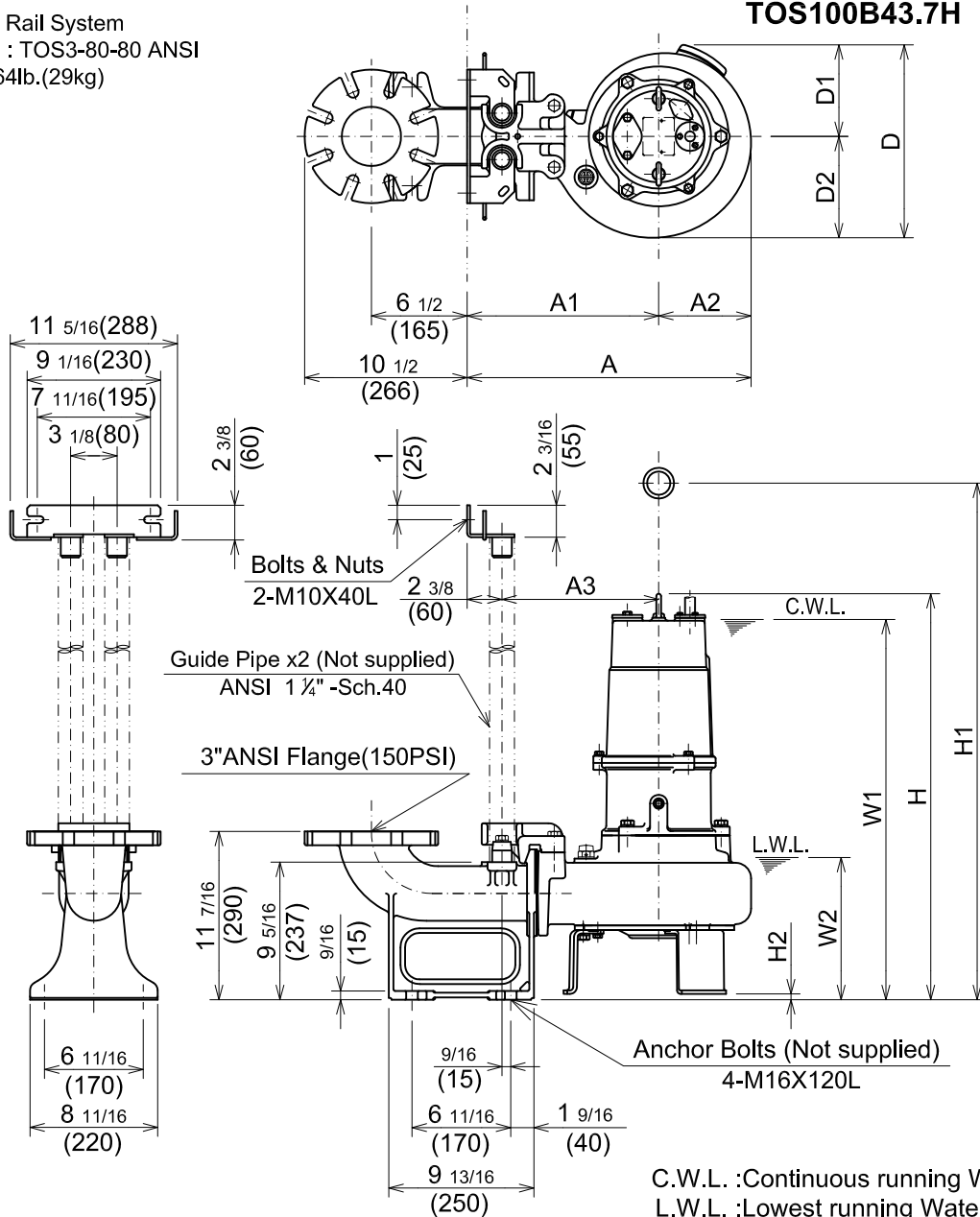

DIMENSIONS:USCS(Inch)

Model	HP	NOM. SIZE	Pump & Motor										C.W.L.	L.W.L.	*Wt. (lbs.)
			A	A1	A2	A3	D	D1	D2	H	H1	H2			
TOS100B42.2 -62	3	3"	19 1/16	13	6 1/16	10 5/8	12 3/4	6 1/4	6 9/16	24 13/16	29 5/8	9/16	23	9 1/2	141
TOS100B43.7 -62	5	3"	19 1/4	13	6 1/4	10 5/8	13 1/8	6 1/4	6 7/8	27 9/16	32 5/16	3/8	25 3/4	9 5/8	176
TOS100B43.7H -63	5	3"	19 5/16	13	6 5/16	10 5/8	13 9/16	6 5/8	6 7/8	26 13/16	31 9/16	9/16	25	9 1/2	172

DIMENSIONS:METRIC(mm)

Model	kW	NOM. SIZE	Pump & Motor										C.W.L.	L.W.L.	*Wt. (kg)
			A	A1	A2	A3	D	D1	D2	H	H1	H2			
TOS100B42.2 -62	2.2	80	484	330	154	270	324	158	166	631	752	15	585	240	64
TOS100B43.7 -62	3.7	80	489	330	159	270	333	158	175	700	821	10	655	245	80
TOS100B43.7H -63	3.7	80	491	330	161	270	344	169	175	681	802	15	635	240	78

*Excluding TOS & Cable.



B-SERIES
SEWAGE & WASTEWATER PUMPS

DIMENSIONS

Guide Rail System
Model : TOS3-80-100 ANSI
Wt. : 68lb.(31kg)

TOS100B42.2 -62
TOS100B43.7 -62
TOS100B43.7H -63

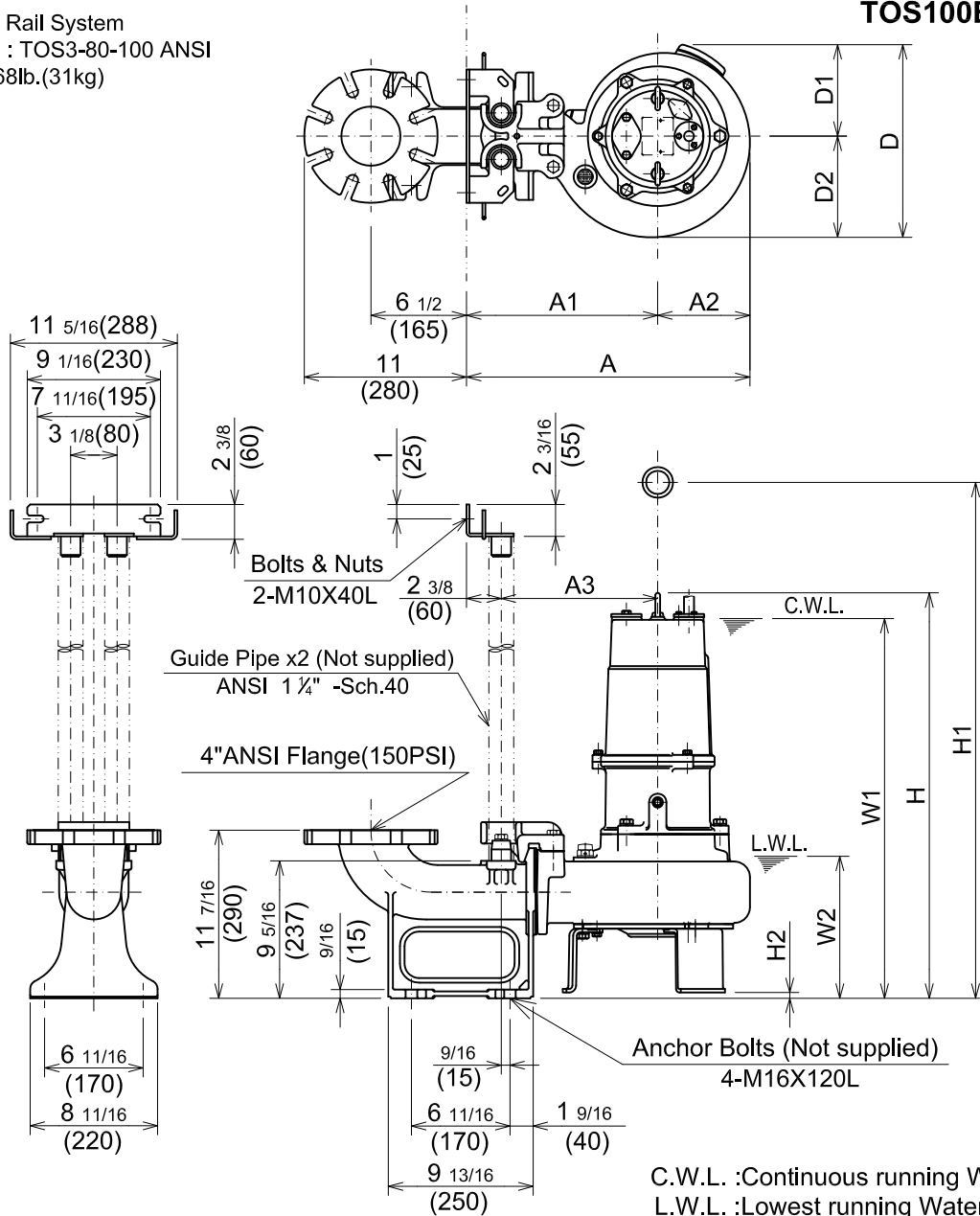

DIMENSIONS:USCS(Inch)

Model	HP	NOM. SIZE	Pump & Motor										C.W.L.	L.W.L.	*Wt. (lbs.)
			A	A1	A2	A3	D	D1	D2	H	H1	H2			
TOS100B42.2 -62	3	4"	19 1/16	13	6 1/16	10 5/8	13 1/16	6 7/16	6 9/16	24 13/16	31 1/8	9/16	23	9 1/2	141
TOS100B43.7 -62	5	4"	19 5/16	13	6 5/16	10 5/8	13 3/8	6 7/16	6 7/8	27 9/16	33 7/8	3/8	25 3/4	9 5/8	176
TOS100B43.7H -63	5	4"	19 5/16	13	6 5/16	10 5/8	13 9/16	6 5/8	6 7/8	26 13/16	33 1/8	9/16	25	9 1/2	170

DIMENSIONS:METRIC(mm)

Model	kW	NOM. SIZE	Pump & Motor										C.W.L.	L.W.L.	*Wt. (kg)
			A	A1	A2	A3	D	D1	D2	H	H1	H2			
TOS100B42.2 -62	2.2	100	484	330	154	270	331	164	167	631	790	15	585	240	64
TOS100B43.7 -62	3.7	100	490	330	160	270	339	164	175	700	860	10	655	245	80
TOS100B43.7H -63	3.7	100	490	330	160	270	344	169	175	681	840	15	635	240	77

*Excluding TOS & Cable.



**B-SERIES
SEWAGE & WASTEWATER PUMPS**

SECTIONAL VIEW

100B42.2 -62
100B43.7 -62
100B43.7H -63

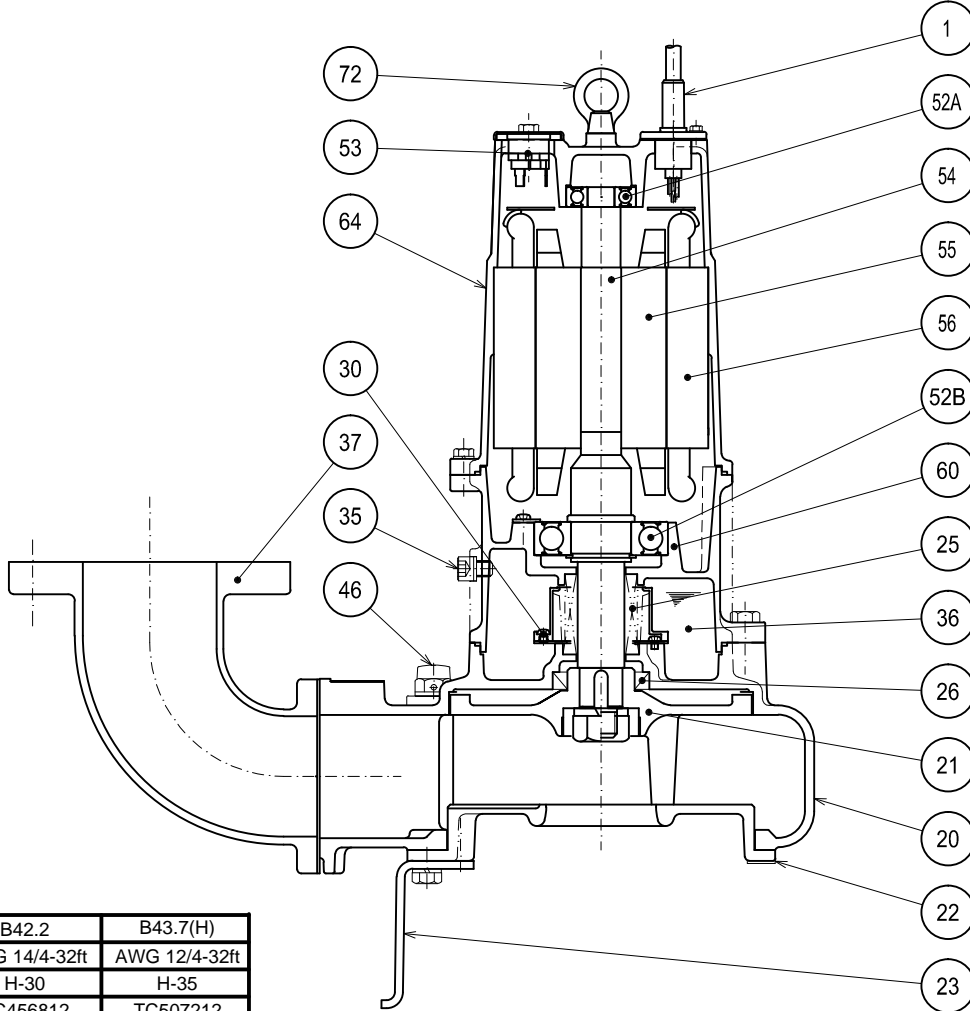

	B42.2	B43.7(H)
* 1	AWG 14/4-32ft	AWG 12/4-32ft
* 2	H-30	H-35
* 3	TC456812	TC507212
* 4	#6307ZZC3	#6309ZZC3

PART#	DESCRIPTION	MAIN MATERIAL / NOTE	RELATED ASTM,AISI CODE	RELATED EN CODE	QTY
1	Power Cable	PVC Sheath * 1			1
20	Pump Casing	Cast Iron	A48M Class30B	EN 1561 GJL-200	1
21	Impeller	Cast Iron	A48M Class30B	EN 1561 GJL-200	1
22	Suction Cover	Cast Iron	A48M Class30B	EN 1561 GJL-200	1
23	Pump Stand	Steel	A283 Grade D	EN 10025 S275	3
25	Mechanical Seal	Silicon Carbide / * 2			1
26	Oil Seal	NBR / * 3			1
30	Oil Lifter	PBT Resin W/GF40			1
35	Oil Plug	Stainless Steel	S 30400	1.4301	1
36	Lubricant	Turbine Oil ISO VG32 or SAE 10W-20			
37	Discharge Bend	Cast Iron / 3"ANSI Flange(150PSI)	A48M Class30B	EN 1561 GJL-200	1
46	Air Release Valve	Nylon			1
52A	Upper Bearing	AC-#6304ZZC3			1
52B	Lower Bearing	* 4			1
53	Motor Protector				1
54	Shaft	Stainless Steel	S 42000	1.4028	1
55	Rotor				1
56	Stator				1
60	Bearing Housing	Cast Iron	A48M Class25B	EN 1561 GJL-150	1
64	Motor Housing	Cast Iron	A48M Class25B	EN 1561 GJL-150	1
72	Lifting Lug Bolt	Stainless Steel	S 30400	1.4301	2



B - SERIES SEWAGE & WASTEWATER PUMPS

SAMPLE SPECIFICATIONS

1. SCOPE OF SUPPLY -

Furnish and install TSURUMI Model _____ Submersible Pump(s). Each unit shall be capable of delivering _____ GPM (_____ m³/min) at _____ Feet (_____ m) TDH. The pump(s) shall be designed to pump waste water, sewage or effluent containing _____ inch (_____ mm) diameter solids without damage during operation. The pump(s) shall be designed so that the shaft power required (BHP)/(kW) shall not exceed the motor rated output throughout the entire operating range of the pump performance curve. The pump discharge size shall be _____ inch, (_____ mm).

2. MATERIALS OF CONSTRUCTION -

Construction of major parts of the pumping unit(s) including pump casing, impeller, and discharge elbow shall be manufactured from gray cast iron, ASTM A48 CLASS 35. Unit(s) shall have a field adjustable and or replaceable, cast iron shear type wear plate or wear rings. Internal and external surfaces coming into contact with the pumpage shall be protected by a fused polymer coating. All exposed fasteners shall be stainless steel. All units shall be furnished with a discharge elbow with 150 lb. (10 kg/cm²) flat face flange and NPT companion flange. Impellers shall be of the solids handling design and shall be slip fit to the shaft and key driven. The pump casing shall incorporate an air relief valve.

3. MECHANICAL SEAL -

All units shall be furnished with a dual inside mechanical shaft seal located completely out of the pumpage, running in a separate oil filled chamber and further protected by an exclusionary oil seal located between the bottom seal faces and the fluid being pumped. Units 2 Hp. and above shall be fitted with a device that shall provide positive lubrication of top mechanical seal, (down to one third of the standard oil level). The device shall not consume any additional electrical power. Mechanical seals shall be rated to preclude the incursion of water up to 42.6 PSI. (98.4 Ft.). Units shall have silicon carbide mechanical seal faces. Mechanical seal hardware shall be stainless steel.

4. MOTOR -

The pump motor(s) shall be _____ Hp., _____ kW., _____ V., 60 Hz., _____ Phase and shall be NEMA MG-1, Design Type B equivalent. Motor(s) shall be rated at _____ full load amps. Motor(s) shall have a 1.15 service factor and shall be rated for 20 starts per hour. Motor(s) shall be air filled, copper wound, class E, B, or F insulated with built in thermal protection for each winding. Motor shaft shall be 420 or 403 stainless steel and shall be supported by two permanently lubricated, high temperature ball bearings, with a B-10 life rating at best efficiency point of 60,000 hours. On units up to 10 Hp. (7.5 kW), the bottom bearing shall be single row, double shielded, C3, deep groove type ball bearings. On units 15 Hp. (11 kW) and above, the bottom bearing shall be two row, double shielded, C3, deep groove type ball bearings. The top bearing on all units shall be single row, double shielded, C3, deep groove type ball bearings. Motor housing and bearing housing shall be gray cast iron, ASTM A48 CLASS 30. Motors shall be D.O.L. or Star-delta start (15 Hp. and above), and shall be suitable for across the line start or variable speed applications, utilizing a properly sized variable frequency drive.

5. POWER CABLE AND CABLE ENTRANCE -

The pump power cable shall be suitable for submersible pump applications. Units up to 5 Hp., (except 150B63.7) shall be supplied with a cable entrance that incorporates built in strain relief, a one piece, three way mechanical compression seal with a fatigue reducing cable boot. On units 7.5 Hp. and above, and 150B63.7, the cable entrance shall incorporate built in strain relief, and combination three way mechanical compression sealing with a fatigue reducing/thermal expansion rubber boot. The power cable shall be field replaceable utilizing standard submersible pump cable. The cable entrance assembly on all units shall contain an anti-wicking block to eliminate water incursion into the motor due to capillary wicking should the power cable be accidentally