



**BK - SERIES
SEWAGE & WASTEWATER PUMPS**

SPECIFICATIONS

■ FEATURES

- 1. Internal cooling jacket offers continued cooling during low sump levels or dry pit Pumping.
- 2. Enclosed Multi-vane, impellers, with field adjustable / replaceable wear plate provides for high wear resistance and enhanced solids handling capability.
- 3. Highly efficient, continuous duty air filled, copper wound motor with class F insulation minimizes the cost of operation.
- 4. Built in thermal protection prevents motor failure due to overloading, accidental run-dry and single phasing in three phase units.
- 5. Double inside mechanical seals with silicon carbide faces, running in an oil filled chamber, equipped with an oil lifter,, and further protected by an exclusionary oil -

- Seal(s), provides for the most durable seal design available.
- 6. Double shielded, permanently lubricated, high temperature C3 ball bearings rated for a B-10 life of 60,000 hours provide for extended operational life.

■ APPLICATIONS

- 1. Commercial, Industrial sewage, wastewater, or effluent transfer.
- 2. Decorative fountains and aquiculture .
- 3. Raw water supply from rivers or lakes.
- 4. Dry pit sump design available.



■ SPECIFICATIONS

Discharge Size
 Horsepower Range
 Performance Range, Capacity Head
 Maximum water temperature
 Materials of Construction
 Casing
 Impeller
 Shaft
 Motor Frame
 Fasteners

 Mechanical Seal
 Elastomers

 Impeller Type
 Solids Handling Capability

 Bearings

 Motor Nomenclature
 Type, Speed, Hz.

 Voltage, Phase

 Insulation
 Accessories

 Operational Mode

■ STANDARD

6" ~ 16" (150 ~ 400 mm)
 30 Hp. ~ 60 Hp. (22 kW ~ 45 kW)
 429 ~ 6340 G.P.M. (1.6 ~ 24.0 m³/min)
 10.7 Ft.~154.2 Ft. (3.3 ~ 47.0m)
 104° F. (40° C.)

 Cast Iron, ASTM 48 Class 35
 Cast Iron, ASTM 48 Class 35
 420 Stainless Steel
 Cast Iron, ASTM 48 Class 30
 304 Stainless Steel

 Silicon Carbide
 NBR (Nitril Buna Rubber)

 Semi-open, Enclosed, solids handling.
 1.57" ~ 4.25" (40 ~ 108 mm)

 Pre-lubricated, Double Shielded

 Air Filled,
 3600, 1800, 1200 & 900 Rpm, 60 Hz.

 460 or 575 V., (3 Phase)

 Class F
 Submersible Power Cable 32' (10 m)

 Manual

■ OPTIONS

Dry-Pit

 Length as required.
 TO/TOS Slide Rail System

GROUP PERFORMANCE RANGE

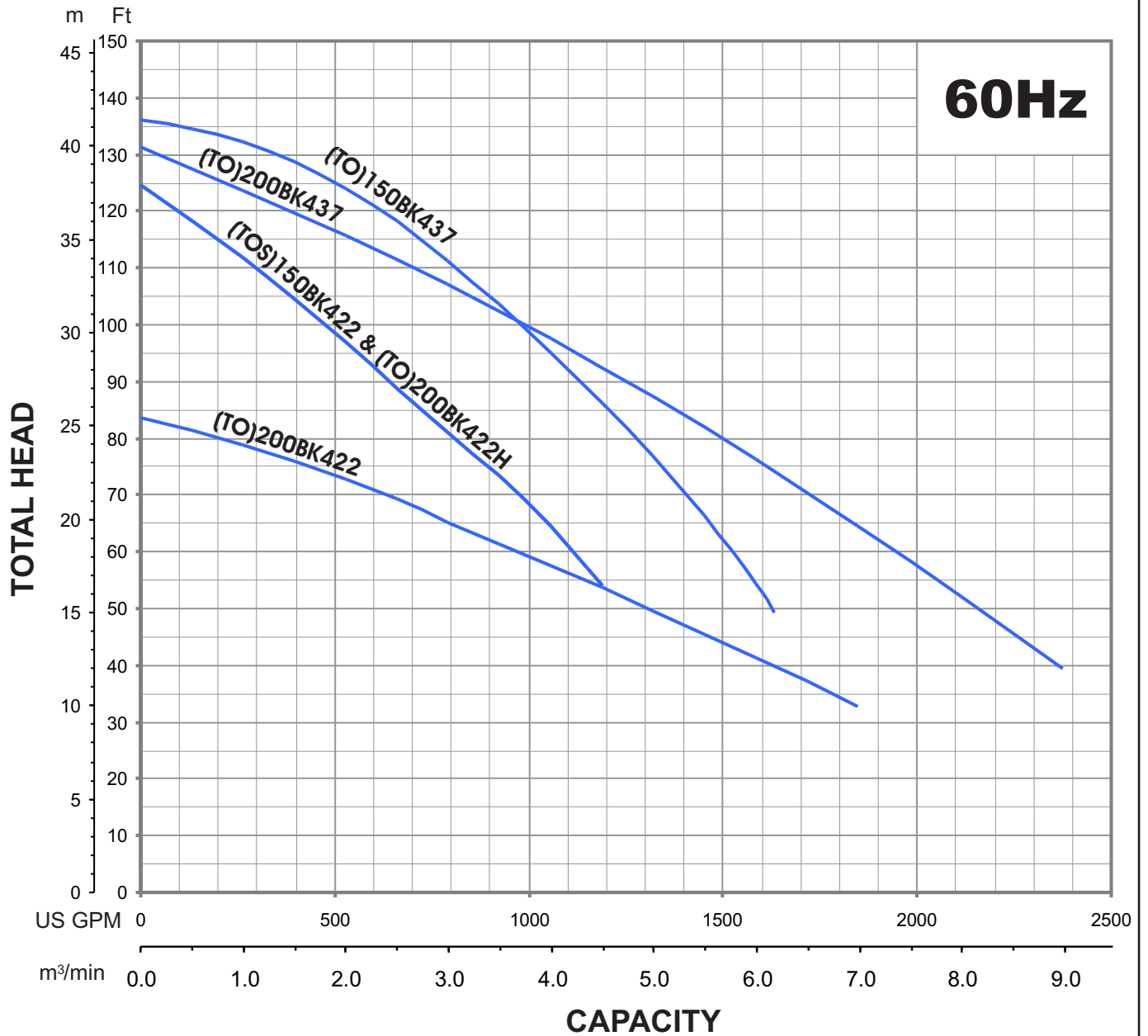



B-SERIES
SEWAGE & WASTEWATER PUMPS

PERFORMANCE
CURVE

MODEL	BORE	HP	KW	RPM	SOLIDS DIA.	LIQUID	SG.	VISCOSITY	TEMP.
(TO)200BK437 -63	8"/200mm	50	37	1770	1.57"/40mm	Water	1.0	1.123cSt.	60°F
PUMP TYPE	PHASE	VOLTAGE	AMPERAGE	HZ	STARTING METHOD	INS.CLASS			
Sewage&Wastewater	3	460 / 575	64 / 50	60	Star-Delta	F			
CURVE No.	DATE	PHASE	VOLTAGE	AMPERAGE	HZ	STARTING METHOD	INS.CLASS		
-	-	-	-	-	-	-	-		

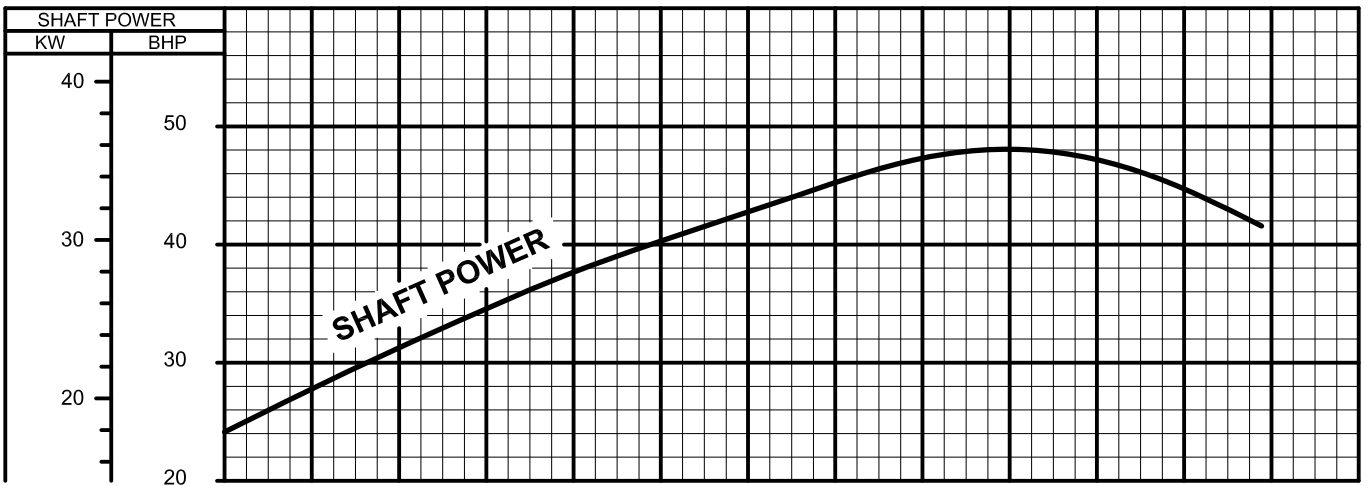
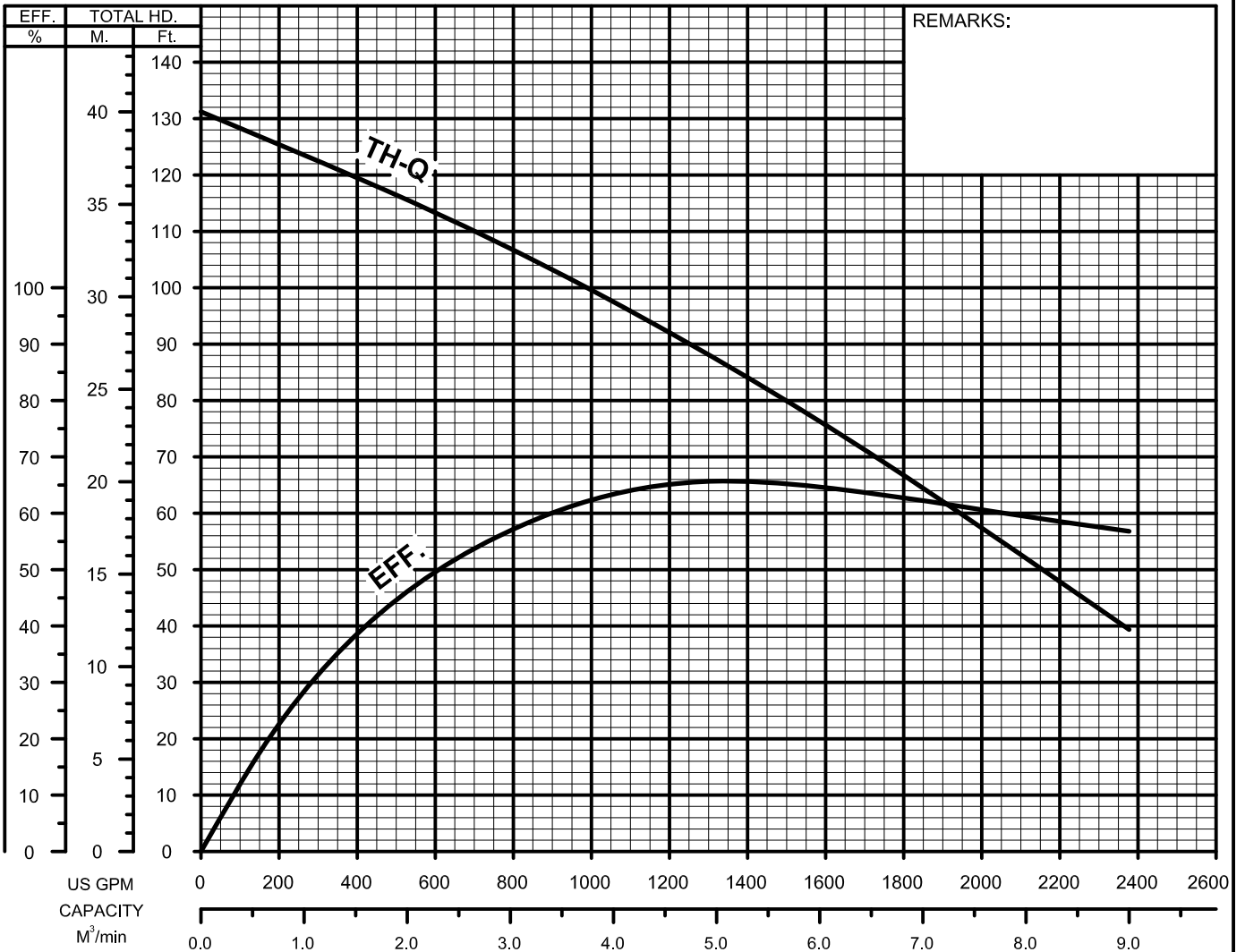

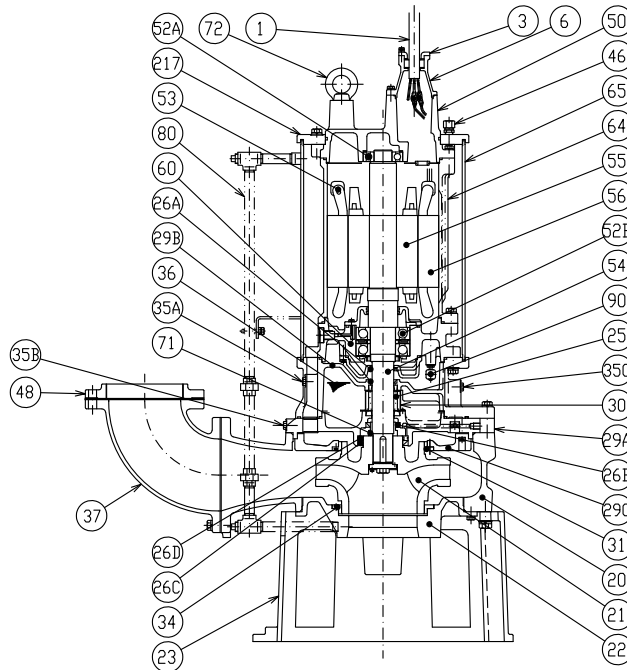

150BK437 -63
200BK437 -63

PART#	DESCRIPTION	MAIN MATERIAL / NOTE	RELATED ASTM,AISI CODE	RELATED EN CODE	QTY
1	Power Cable	Chloroprene Sheath AWG 4/4-32ft			1
	Power Cable	Chloroprene Sheath AWG 4/3-32ft			1
	Control Cable	Chloroprene Sheath AWG 14/4-32ft			1
3	Gland	Cast Iron	A48M Class30B	EN 1561 GJL-200	2
6	Stuffing Box	Cast Iron	A48M Class30B	EN 1561 GJL-200	2
20	Pump Casing	Cast Iron	A48M Class35B	EN 1561 GJL-250	1
21	Impeller	Cast Iron	A48M Class35B	EN 1561 GJL-250	1
22	Suction Cover	Cast Iron	A48M Class35B	EN 1561 GJL-250	1
23	Suction Strainer	Ductile Cast Iron	A536 80-55-06	EN 1563 GJS-500-7	1
25	Mechanical Seal	Silicon Carbide / H-60			1
26A	Oil Seal	NBR / TC60789			2
26B	Oil Seal	NBR / TC709513			1
26C	Oil Seal	NBR / TC11014014			1
26D	Labyrinth ring	Stainless Steel	S 30400	1.4301	1
29A	Oil Casing	Cast Iron	A48M Class35B	EN 1561 GJL-250	1
29B	Casing Cover	Cast Iron	A48M Class35B	EN 1561 GJL-250	1
29C	Casing Plate	Cast Iron	A48M Class35B	EN 1561 GJL-250	1
30	Oil Lifter	Steel (Cold Rolled)	A109/A1008	EN 10130	1
31	Wear Ring	Cast Iron	A48M Class35B	EN 1561 GJL-250	1
34	Mouth Ring	Cast Iron	A48M Class35B	EN 1561 GJL-250	1
35A	Oil Plug	Stainless Steel	S 30400	1.4301	2
35B	Oil Plug	Stainless Steel	S 30400	1.4301	1
35C	Drain Plug	Stainless Steel	S 30400	1.4301	1
36	Lubricant	Turbine Oil ISO VG32 or SAE 10W-20			
37	Discharge Bend	Cast Iron	A48M Class30B	EN 1561 GJL-200	1
46	Air Release Valve	Stainless Steel	S 30400	1.4301	1
48	Companion / Welded Flange	Cast Iron / 6"NPT Companion or 8" Welded	A48M Class30B	EN 1561 GJL-200	1
50	Motor Bracket	Cast Iron	A48M Class30B	EN 1561 GJL-200	1
52A	Upper Bearing	#6310ZZC3			1
52B	Lower Bearing	#7314BDB			1
53	Motor Protector				3
54	Shaft	Stainless Steel	S 42000	1.4021	1
55	Rotor				1
56	Stator				1
60	Bearing Housing	Cast Iron	A48M Class30B	EN 1561 GJL-200	1
64	Motor Housing	Cast Iron	A48M Class30B	EN 1561 GJL-200	1
65	Outer Cover	Steel Pipe (& Steel)	A53 Type F (& A283 Grade D)	DIN 1615 St 33 (& EN 10025 S275)	1
71	Shaft Sleeve	Stainless Steel	S 30400	1.4301	1
72	Lifting Lug Bolt	Stainless Steel	S 30400	1.4301	2
80	Cooling Pipe Set	Steel	A283 Grade D	EN 10025 S275	1
90	Leak Sensor (Float)				1
217	Fixing Plate	Cast Iron	A48M Class30B	EN 1561 GJL-200	1



**B-SERIES
SEWAGE & WASTEWATER PUMPS**

DIMENSIONS

200BK437 -63

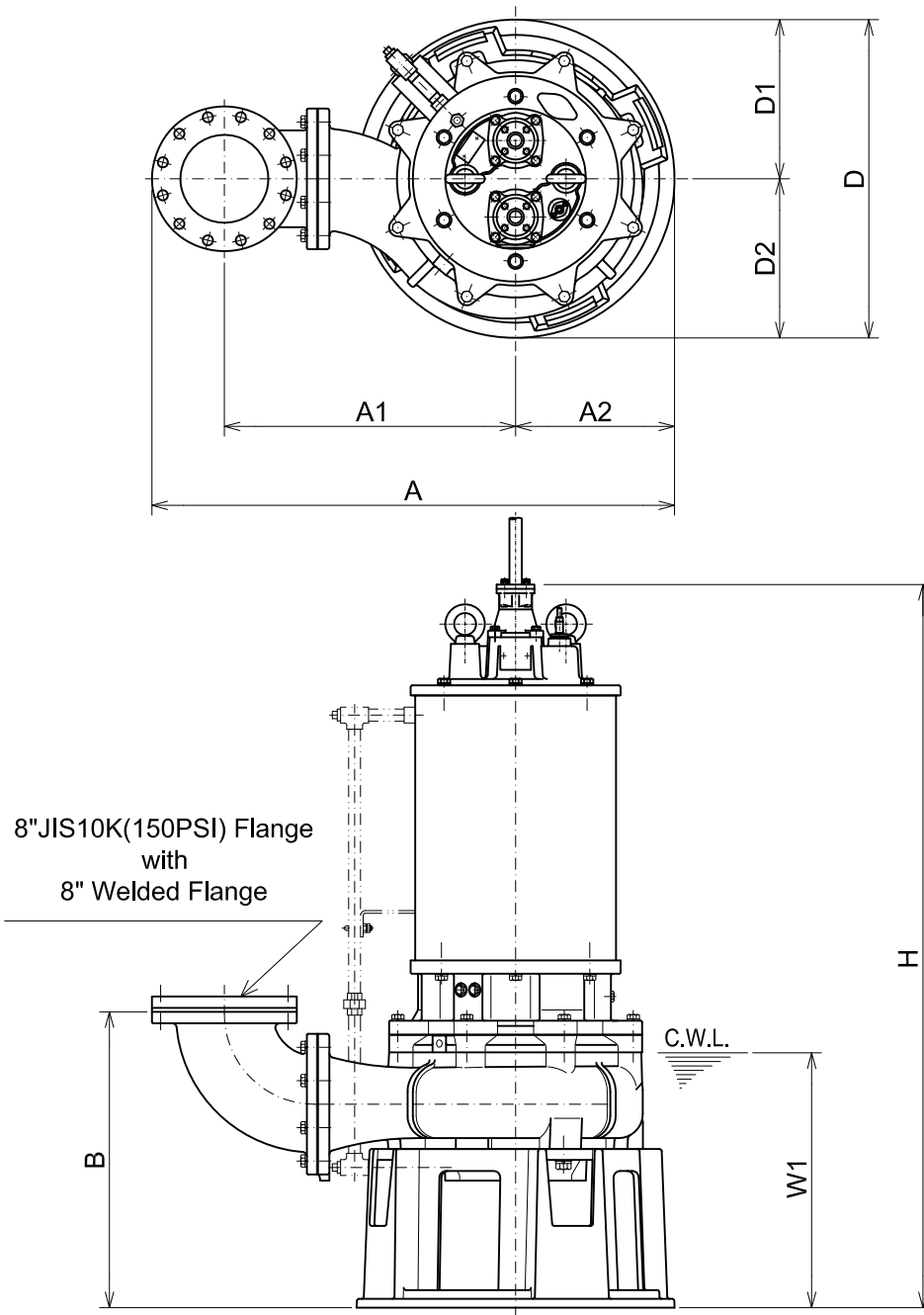

C.W.L. :Continuous running Water Level

DIMENSIONS:USCS(Inch)

Model	HP	NOM. SIZE	Pump & Motor								C.W.L.	*Wt.
			A	A1	A2	B	D	D1	D2	H	W1	(lbs.)
200BK437 -63	50	8"	46 7/8	26 1/8	14 1/4	26 1/2	28 1/2	14 1/4	14 1/4	64 9/16	22 7/8	1870

DIMENSIONS:METRIC(mm)

Model	kW	NOM. SIZE	Pump & Motor								C.W.L.	*Wt.
			A	A1	A2	B	D	D1	D2	H	W1	(kg)
200BK437 -63	37	200	1190	663	362	673	724	362	362	1640	580	850

*Excluding Cable

TO200BK437 -63

Guide Rail System : TO-200
Weight : 198lbs. (90kg)

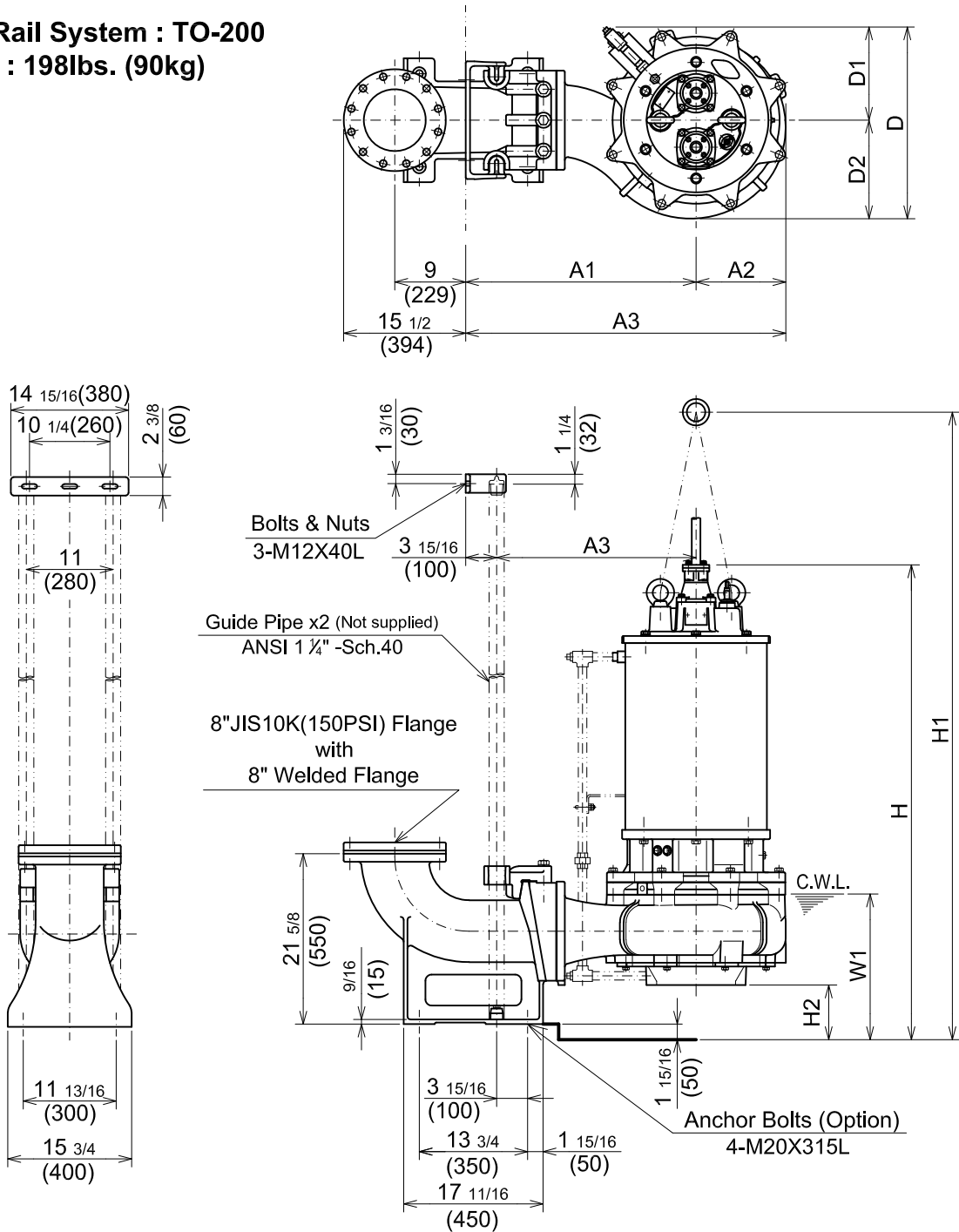

C.W.L. :Continuous running Water Level

DIMENSIONS:USCS (Inch)

Model	HP	NOM. SIZE	Pump & Motor										C.W.L. W1	*Wt. (lbs.)
			A	A1	A2	A3	D	D1	D2	H	H1	H2		
TO200BK437-63	50	8"	40 11/16	29 5/16	11 7/16	25 3/8	24 3/8	11 7/8	12 1/2	60 1/8	79 1/2	6 15/16	18 1/2	1660

DIMENSIONS:METRIC (mm)

Model	kW	NOM. SIZE	Pump & Motor										C.W.L. W1	*Wt. (kg)
			A	A1	A2	A3	D	D1	D2	H	H1	H2		
TO200BK437-63	37	200	1034	744	290	644	619	301	318	1527	2020	176	470	755

*Excluding TO & Cable