

**DISCHARGE BENDS**

An alternative to the guiderail system, the free standing pump installation provides for a simple set-up that saves space and money. Instead of permanently anchoring a discharge base assembly with guide rails, a 90° discharge bend is assembled to the pump ahead of lowering into the pit. The pump is then lowered into the pit along with flexible discharge piping connecting discharge bend to downstream piping. Unlike the guiderail system, the pump sits on and is supported by the bottom of the pit. It may be necessary to fabricate a raised surface for the pump to sit above solid waste.

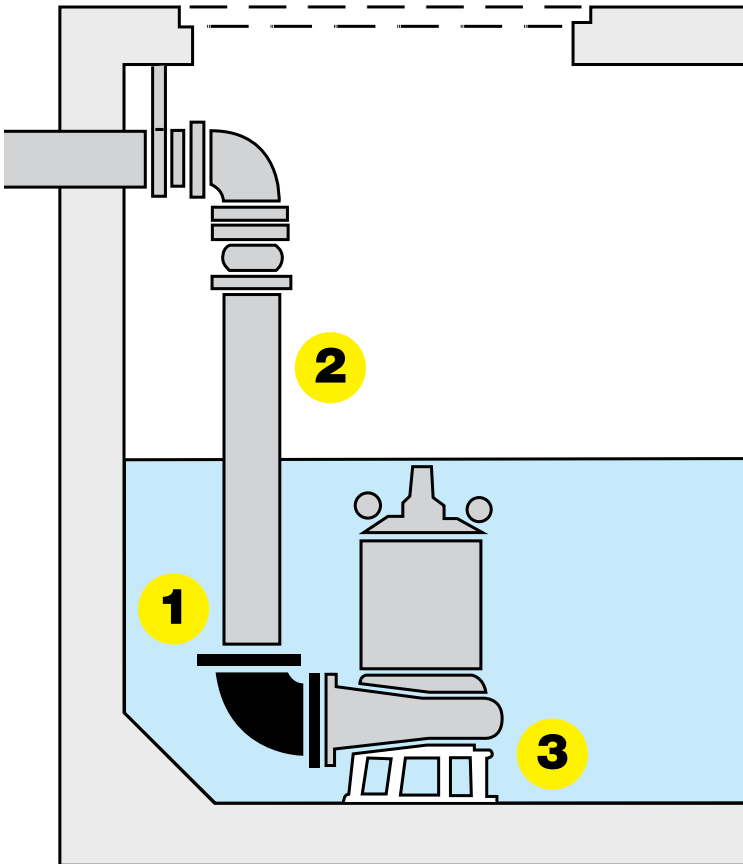

**1 DISCHARGE BEND**

A typically 90° bend orientated to direct flow horizontally from pump discharge vertically out of the pit. End connections designed with a combination of either flange faces or threaded pipe connections. Note, utilize flange gaskets or PTFE thread sealing tape with discharge bends

**2 FLEX DISCHARGE HOSE**

There are two primary reasons a flexible discharge pipe or hose is needed for free standing installs. First, it make for simple install. The pump lowers with pre-assembled connection and is ready to go.

Second, when lowering the pump there is no way to repeatedly lower in the same spot. The distance from discharge to the downstream pipe will always vary. Flexible piping / hose will alleviate this difference where hard pipe would be stressed leading to potential failure.

**3 PUMP BASE**

The weight of the pump, bend and flexible pipe will primarily be supported by the pump base on the pit floor. If the pit is susceptible to solids, a raised platform may be needed to prevent clogging.

**S-BEND**

Designed for confined areas that typical discharge bends may run into clearance concerns (i.e. sewer bypass). The S-Bend design has a reduced overall width compared to similar sized discharge bends. Please contact Tsurumi for specific dimensions as well as what pump models are offered with S-Bend options.

