



LSC - SERIES
RESIDUAL WATER - DEWATERING PUMP

SPECIFICATIONS

■ FEATURES

1. Semi-open, Ductile Iron impeller with replaceable / adjustable wearplate and built in check valve allows for residual water removal down to 0.04" of an inch.
2. Double inside mechanical seals with silicon carbide faces, running in an oil filled chamber and further protected by a lip seal running against a replaceable, 403 stainless steel shaft sleeve, provides for the most durable seal design available.
3. Highly efficient, continuous duty, air filled, copper wound motor with class E insulation minimizes the cost of operation.
4. Built in thermal & amperage Sensing protector prevents motor failure due to-

overloading or accidental run -dry conditions.

5. Double shielded, permanently lubricated, high temperature C3 ball bearings rated for a B-10 life of 60,000 hours extend operational life.
6. Top discharge, flow-thru design enables operation at low water levels for extended periods.

■ APPLICATIONS

1. Residential, commercial, industrial residual drainage.
2. Basement sump pump (does not require a sump).
3. Decorative waterfalls and fountains.



■ SPECIFICATIONS

- Discharge Size
- Horsepower Range
- Performance Range Capacity Head
- Maximum water temperature
- Materials of Construction
 - Casing
 - Impeller
 - Shaft
 - Motor Frame
 - Fasteners
- Mechanical Seal
 - Upper Seal
 - Lower Seal
 - Elastomers
- Impeller Type
- Solids Handling Capability
- Bearings
- Motor Nomenclature
 - Type, Speed, Hz.
 - Voltage, Phase
 - Insulation
- Accessories
- Operational Mode

■ STANDARD

- 3/4" NPT (19 mm)
- 2/3 HP. (0.48 Kw)
- 13.2 ~ 45.0 GPM. (0.05 ~ 0.17 m³/min)
- 12.1 ~ 39.0 Ft. (3.70 ~ 11.89 m)
- 104° F. (40° C.)
- Ethylene Propylene Rubber
- Urethane Rubber
- 403 Stainless Steel
- Aluminum alloy
- 304 Stainless Steel
- Silicon Carbide
- NBR (Nitrile Butadiene Rubber)
- Semi-vortex, solids handling.
- 0.236" (6.0mm)
- Prelubricated, Double Shielded
- Air Filled, 3600 RPM, 60 Hz.
- 115 / 230V., 1 Phase
- Class E
- Submersible Power Cable 20' (6.2 m)
- Manual

■ OPTIONS

Length as Required,



TSURUMI PUMP

LSC - SERIES
RESIDUAL WATER - DEWATERING PUMP

PERFORMANCE
RANGE

GROUP PERFORMANCE RANGE

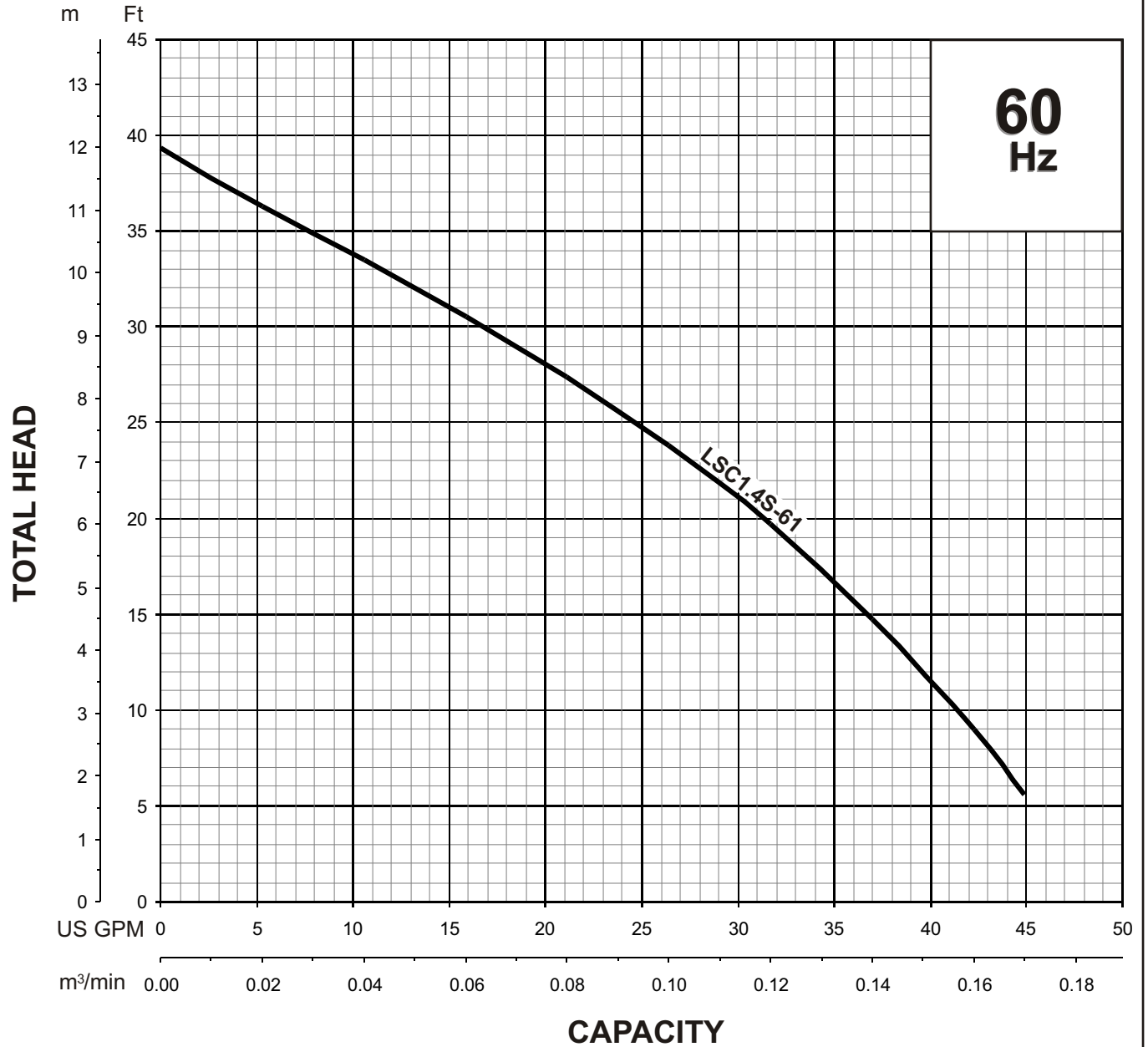



LSC - SERIES RESIDUAL WATER - DEWATERING PUMP

PERFORMANCE CURVE

MODEL	BORE	HP	KW	RPM	SOLIDS DIA	LIQUID	SG.	VISCOSITY	TEMP.
LSC1.4S-61	3/4" / 19mm	0.64	0.48	3255	0.236"/6mm	Water	1.0	1.123 cSt.	60°F
PUMP TYPE	PHASE	VOLTAGE	AMPERAGE	HZ	STARTING METHOD	INS. CLASS			
Residual Water- Dewatering Pump	Single	110/115/120, 230	6.1 / 5.9 / 5.7 , 3.0	60	Capacitor Start	E			
CURVE No.	DATE	PHASE	VOLTAGE	AMPERAGE	HZ	STARTING METHOD	INS. CLASS		
-	-	-	-	-	-	-	-		

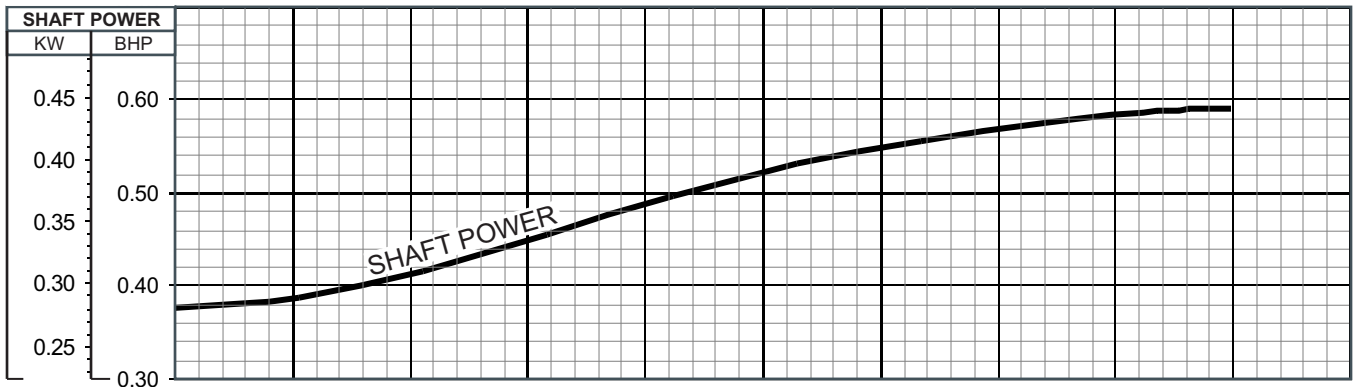
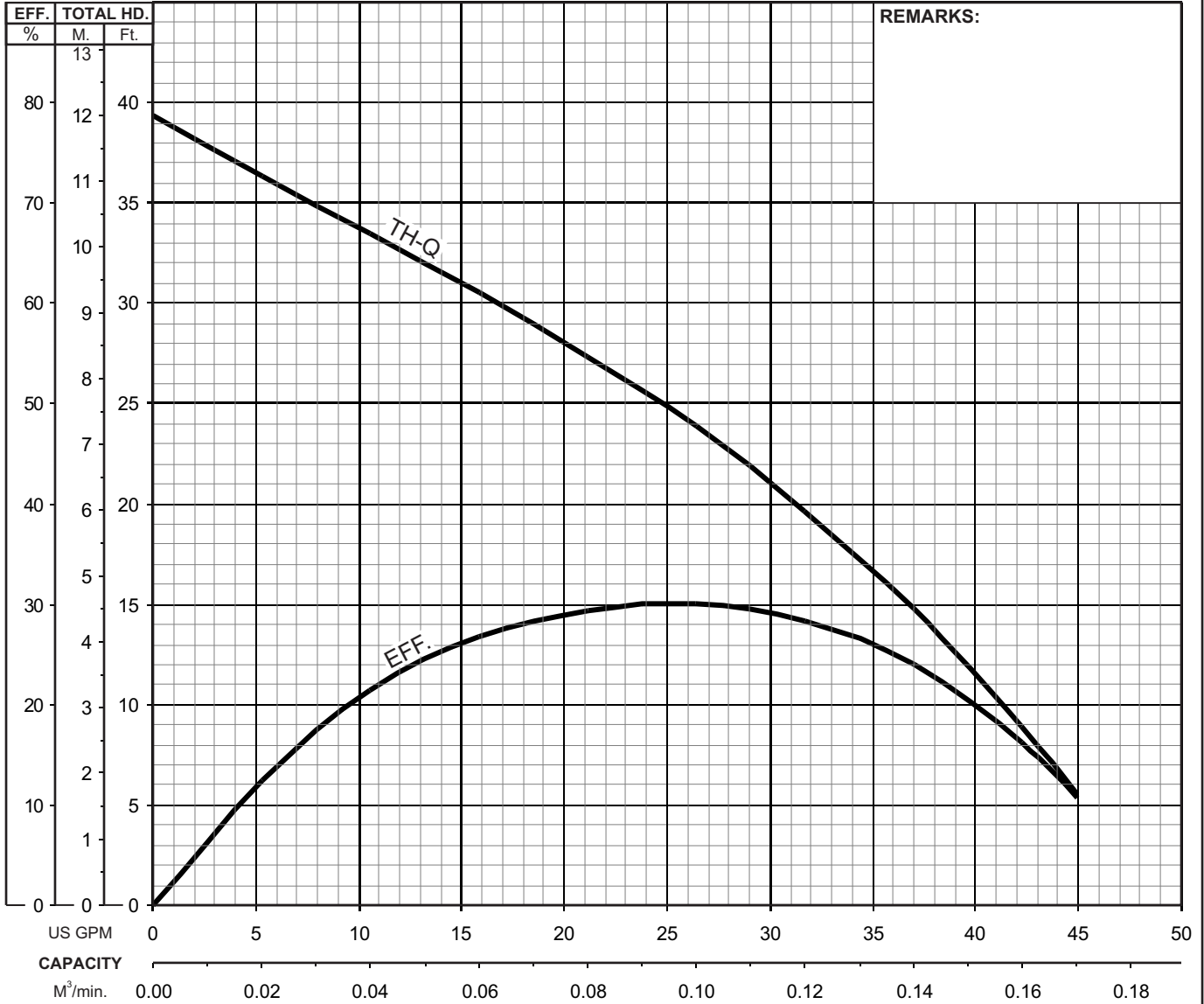



LSC - SERIES
RESIDUAL WATER - DEWATERING PUMP

DIMENSIONS

LSC1.4S-61

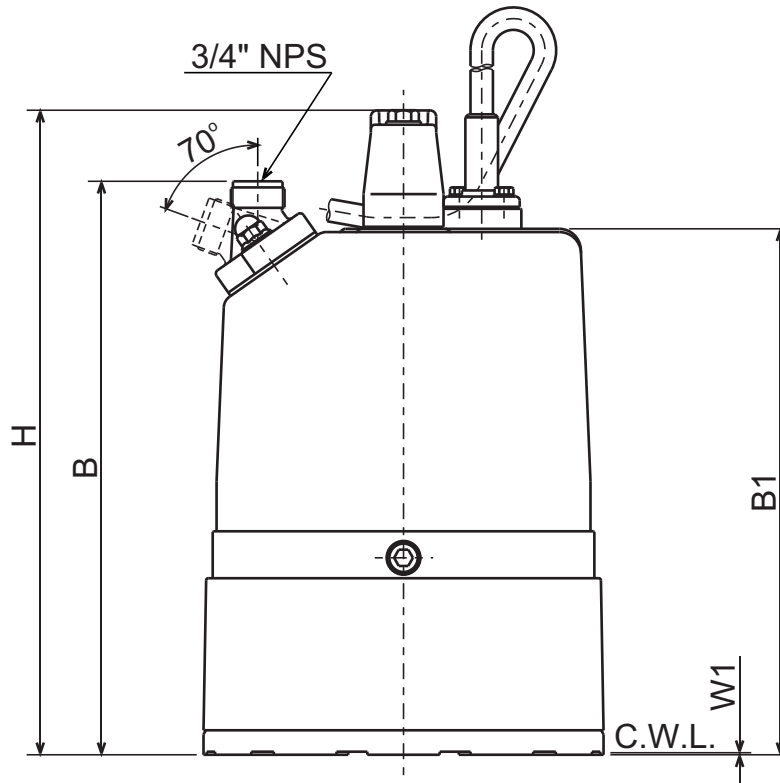
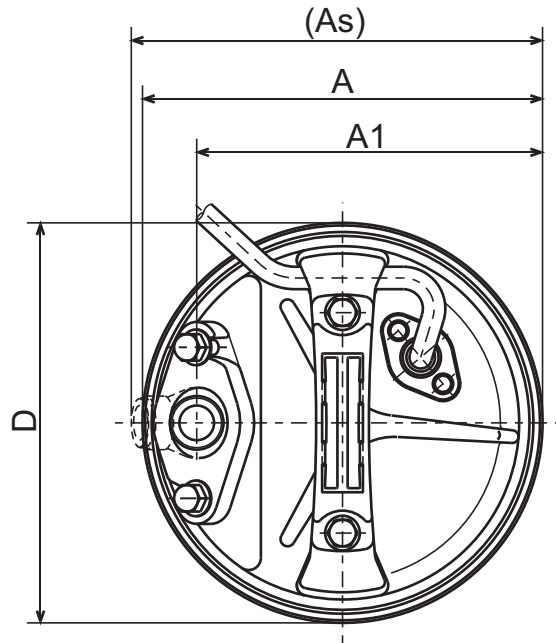

C.W.L. : Continuous running Water Level

DIMENSIONS:USCS (Inch)

Model	HP	NOM. SIZE	Pump & Motor							C.W.L.	Wt. (lbs.)
			A	As	A1	B	B1	D	H	W1	
LSC1.4S-61	2/3	3/4"	7 11/16	7 15/16	6 11/16	11 1/16	10 1/8	7 11/16	12 7/16	0.04	26

DIMENSIONS:METRIC (mm)

Model	kW	NOM. SIZE	Pump & Motor							C.W.L.	Wt. (kg)
			A	As	A1	B	B1	D	H	W1	
LSC1.4S-61	0.48	19	196	202	169	281	258	196	316	1	12.0

**TSURUMI PUMP**

LSC - SERIES
RESIDUAL WATER - DEWATERING PUMP

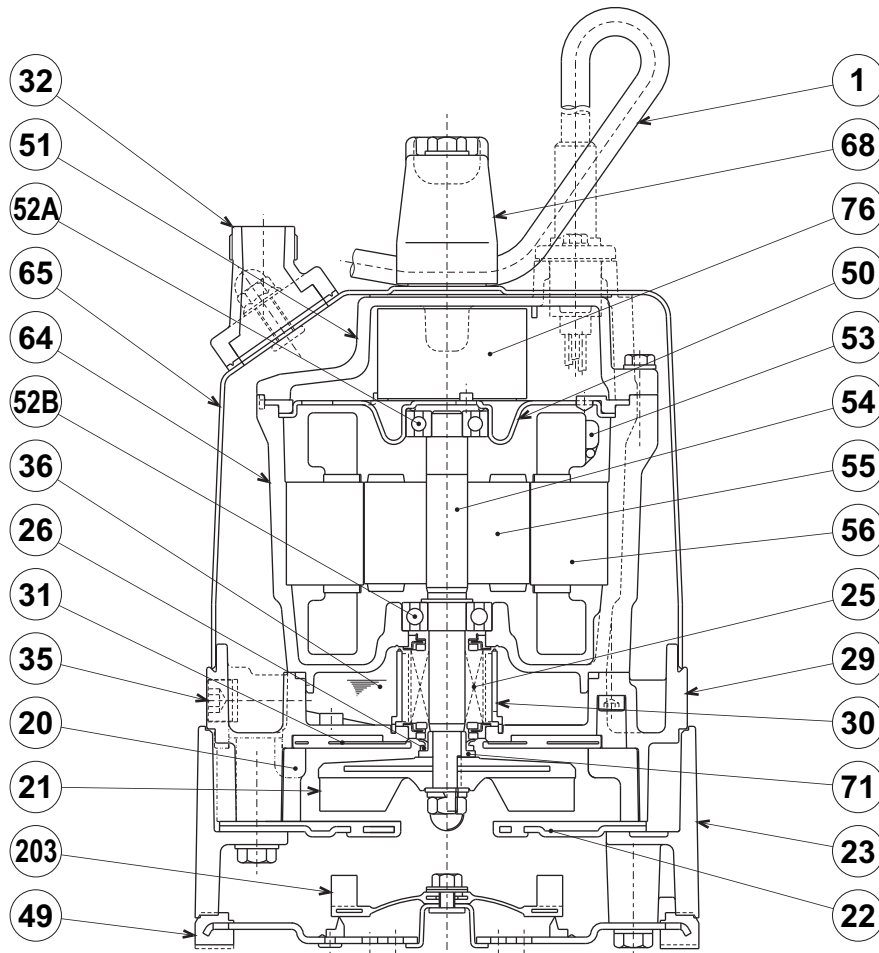
SECTIONAL VIEW**LSC1.4S-61**

ITEM#	DESCRIPTION	MAIN MATERIAL / NOTE	RELATED ASTM, AISI CODE	RELATED EN CODE	Q'TY
1	Power Cable	PVC Sheath AWG16/3-20ft			1
20	Pump Casing	Ethylene Propylene Rubber			1
21	Impeller	Urethane Rubber			1
22	Suction Cover	Urethane Rubber + Steel (Cold Rolled)	(A109/A1008)	(EN 10130)	1
23	Stand	Aluminum Alloy Die Casting	B85 383.0	EN 1706 AC-46100	1
25	Mechanical Seal	Silicon Carbide / W-14VL			1
26	V-Ring	Nitrile Butadiene Rubber			1
29	Oil Casing	Aluminum Alloy Die Casting	B85 383.0	EN 1706 AC-46100	1
30	Oil Lifter	PBT Resin			1
31	Wearing Plate	Urethane Rubber			1
32	Discharge Connection	Aluminum Alloy Die Casting / NPS 3/4"	B85 383.0	EN 1706 AC-46100	1
35	Oil Plug	Stainless Steel	S 30400	1.4301	1
36	Lubricant	Turbine Oil ISO VG32 or SAE10W -20			
49	Bottom Plate	Steel (Cold Rolled) + NBR Rubber	A109/A1008	EN 10130	1
50	Motor Bracket	Steel (Electro-Galvanized)	A591	EN 10152	1
51	Motor Head Cover	Aluminum Alloy Die Casting	B85 383.0	EN 1706 AC-46100	1
52A	Upper Bearing	#6201ZZC3			1
52B	Lower Bearing	#6202ZZC3			1
53	Motor Protector				1
54	Shaft	Stainless Steel	S 40300	1.4000	1
55	Rotor				1
56	Stator				1
64	Motor Housing	Aluminum Alloy Die Casting	B85 383.0	EN 1706 AC-46100	1
65	Outer Cover	Steel (Cold Rolled)	A109/A1008	EN 10130	1
68	Handle	ABS Resin			1
71	Shaft Sleeve	Stainless Steel	S 30400	1.4301	1
76	Capacitor				1
203	Swing Check Valve	Styrene Butadiene Rubber			1

Surface Level Switch - LSC

Automate Utility / Floor Pumps

DESCRIPTION OF OPERATION



The Surface Level Switch is used to automate a utility/floor sucking pump. Set the Surface Level Switch on the floor and plug the power cord from the pump into the piggyback plug on the switch. Plug the piggyback plug into a standard 120 VAC wall outlet (the unit will also work on GFI outlets).

When water touches the "On Probe", the pump will turn on. A 10-second delay timer keeps the pump running when water is no longer touching the "Off Probes". The time delay feature also prevents rapid pump cycling if the water has ripple or wave action. The switch is filled with epoxy so it can be completely submerged in water and operate properly.

The switch is designed to turn on at 0.375" ($\frac{3}{8}$ ") liquid level and turn off at 0.125" ($\frac{1}{8}$ "). Leveling screws are provided and are optionally used for leveling or to slightly adjust the on and off liquid level set points. The Surface Level Switch uses an isolated patented circuit that detects water with no shock hazard at the probes. This product is for use with the Tsurumi LSC1.4S pump.

The Surface Level Switch connected to utility pumps is the ideal solution for problem areas such as shallow water accumulations due to flooding, ground water intrusion or broken water pipes.

FEATURES

Epoxy Filled Electronics - Completely Waterproof

Wide Base for Stability



Stainless Steel Water Detection Probes

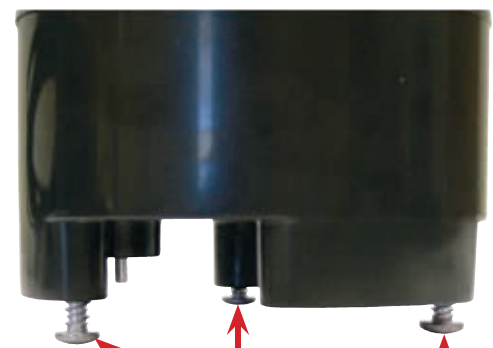

Screws for Leveling or Height Adjustment - Provided for Optional Use



SPECIFICATIONS

Surface Level Switch

Housing Material

ABS Plastic

Probe Material

Stainless Steel

Voltage on Probe

12 VDC from Internal Class 2 Isolated Transformer

Electrical

120 VAC, 15 Amps

Cord Material

SJEOOW - 14 AWG

Piggyback Plug

NEMA 5-15 PR

On Level

0.375" No Screws Used

0.475" - 0.775" Adjustable (If using screws)

Off Level

0.125" No Screws Used

0.225" - 0.525" Adjustable (If using screws)

MECHANICAL DRAWING

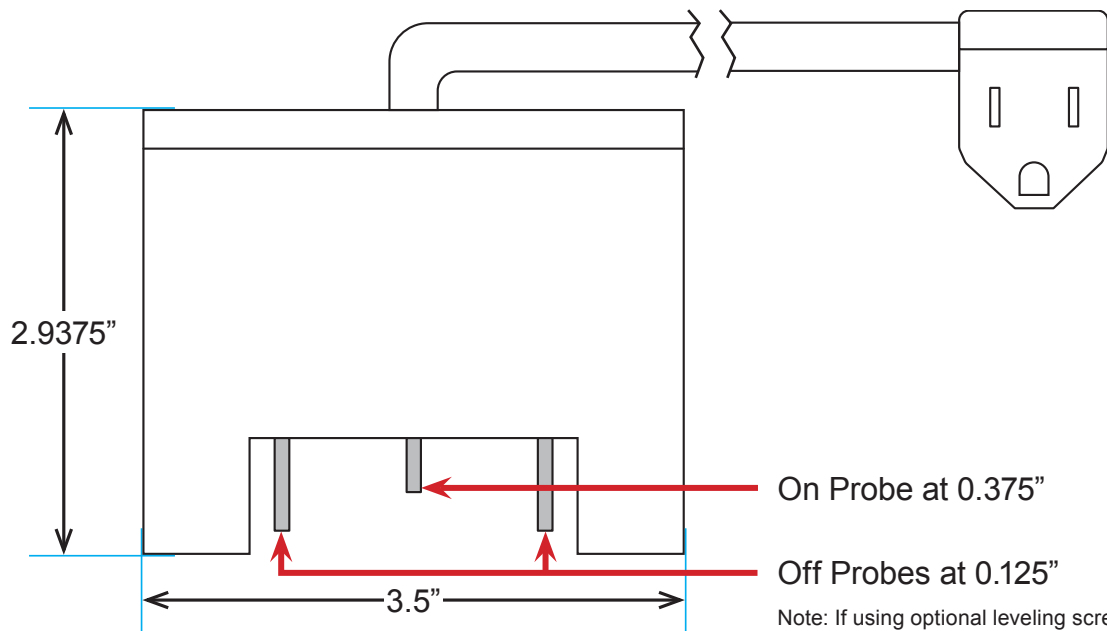

ORDERING INFORMATION

PART NUMBER	DESCRIPTION
SLS-LSC20	Surface Level Switch, 20' Cord, 120 VAC Piggyback Plug
SLS-LSC50	Surface Level Switch, 50' Cord, 120 VAC Piggyback Plug

TSURUMI PUMP
**LSC - SERIES
RESIDUAL WATER - DEWATERING PUMP**
**SAMPLE
SPECIFICATIONS**
1. SCOPE OF SUPPLY -

Furnish and install TSURUMI Model LSC1.4S-61 Submersible Pump(s).

Each unit shall be capable of delivering _____ GPM (_____ m³/min) at _____ Feet (_____ m) TDH. The pump(s) shall be designed to pump waste water, down to 3/64", without damage during operation. The pump(s) shall be designed so that the shaft power required (BHP)/(kW) shall not exceed the motor rated output throughout the entire operating range of the pump performance curve. Pump(s) shall be of the top discharge, flow through design.

2. MATERIALS OF CONSTRUCTION -

Construction of major parts of the pumping unit(s) shall be as follows: Pump casing shall be gray cast iron, ATSM A48 CLASS 35. Motor frame shall be carbon steel. Internal and external surfaces coming into contact with the pumpage shall be protected by a fused polymer coating. All exposed fasteners shall be stainless steel. All units shall be furnished with 3/4" NPS, garden hose discharge connector. Impellers shall be of the multi-vane, ductile cast iron, semi-open solids handling design and shall be slip fit to the shaft and key driven. Units shall incorporate a check valve on the suction side of the pump and shall not require a sump.

3. MECHANICAL SEAL -

All units shall be furnished with a dual inside mechanical shaft seal located completely out of the pumpage, running in a separate oil filled chamber and further protected by an exclusionary oil seal located between the bottom seal faces and the fluid being pumped. Mechanical seals shall rated to preclude the incursion of water up to 13.9 PSI (32 Ft.) submergence. Units shall have silicon carbide mechanical seal faces. Mechanical seal hardware shall be stainless steel.

4. MOTOR-

The pump motor(s) shall be 1/2 HP., 0.40 kW., 115 / 230V., 60 Hz. 1 Phase and shall be NEMA MG-1, Design Type B equivalent. Motor(s) shall be rated at 5.9 / 3.0 full load amps. Motor(s) shall have a 1.15 service factor and shall be rated for 10 starts per hour. Motor(s) shall be air filled, copper wound, class E insulated with built in thermal and over amperage protection. Motor shaft shall be 403 stainless steel, fitted with a replaceable 430 stainless steel shaft sleeve and shall be supported by two permanently lubricated, high temperature ball bearings, with a B-10 life rating at best efficiency point of 60,000 hours. Bearings on all units shall be single row, double shielded, C3, deep groove type ball bearing.

5. POWER CABLE AND CABLE ENTRANCE -

The pump power cable shall be suitable for submersible pump applications. The cable entrance shall incorporate built in strain relief, and a one piece, three way mechanical compression seal with a fatigue reducing cable boot. The cable entrance assembly shall contain an anti-wicking block to eliminate water incursion into the motor due to capillary wicking should the power cable be accidentally damaged.