



BZ - SERIES
SINGLE VANE - SEWAGE & WASTE WATER PUMPS

SPECIFICATIONS

FEATURES

1. Single Vane, Cast Iron, impeller passes 3" diameter solids without clogging providing for highly efficient pumping of raw sewage and waste water.
2. Double inside mechanical seals with silicon carbide faces, running in an oil filled chamber and further protected by a lip seal, provides for the most durable seal design available.
3. Highly efficient, continuous duty, air filled, copper wound motor with class F, insulation minimizes the cost of operation.
4. Built in thermal & amperage sensing, protector prevents motor failure due to overloading, single phasing (in three phase units), or accidental run -dry conditions.
5. Double shielded, permanently lubricated, high temperature C3 ball bearings rated for a B-10 life of 60,000 hours, extend operational life.

APPLICATIONS

1. Residential, commercial, industrial sewage, effluent, wastewater and site drainage.
2. Decorative waterfalls, fountains and fish ponds.
3. Raw water supply from rivers or lakes.



SPECIFICATIONS

Discharge Size
 Horsepower Range
 Performance Range Capacity
 Head
 Maximum water temperature
 Materials of Construction
 Casing
 Impeller
 Shaft
 Motor Frame
 Fasteners
 Mechanical Seal
 Elastomers
 Impeller Type
 Solids Handling Capability
 Bearings
 Motor Nomenclature
 Type, Speed, Hz.
 Voltage, Phase
 Insulation
 Accessories
 Operational Mode

STANDARD

4" Npt (100 mm)
 2 ~15 Hp. (1.5 ~ 11 kW)
 105.7 ~ 951.0 Gpm. (.40 ~ 3.60 m³/min)
 21.0 Ft. ~ 101.7Ft. (6.4 ~ 31.0 m)
 104° F. (40° C.)
 ASTM 48 Class 35 Cast Iron
 ASTM 48 Class 35 Cast Iron
 420,403 Stainless Steel
 ASTM 48 Class 35 Cast Iron
 304 Stainless Steel
 Silicon Carbide
 NBR (Nitril Buna Rubber)
 Enclosed Single Vane, solids handling.
 3.15" (80 mm)
 Pre-lubricated, Double Shielded
 Air Filled, 1800 Rpm, 60 Hz.
 208-230, 230 or 440, 460 or 575 V.
 (3 Phase)
 Class F
 Submersible Power Cable 32' (10 m)
 Manual

OPTIONS

Nema 3R inverter available for
 230 V., 1 Ph. operation from
 2~5 Hp.
 Length as Required
 Model
 TOS Slide rail system



BZ - SERIES SEWAGE & WASTEWATER PUMPS

PERFORMANCE RANGE

PERFORMANCE RANGE

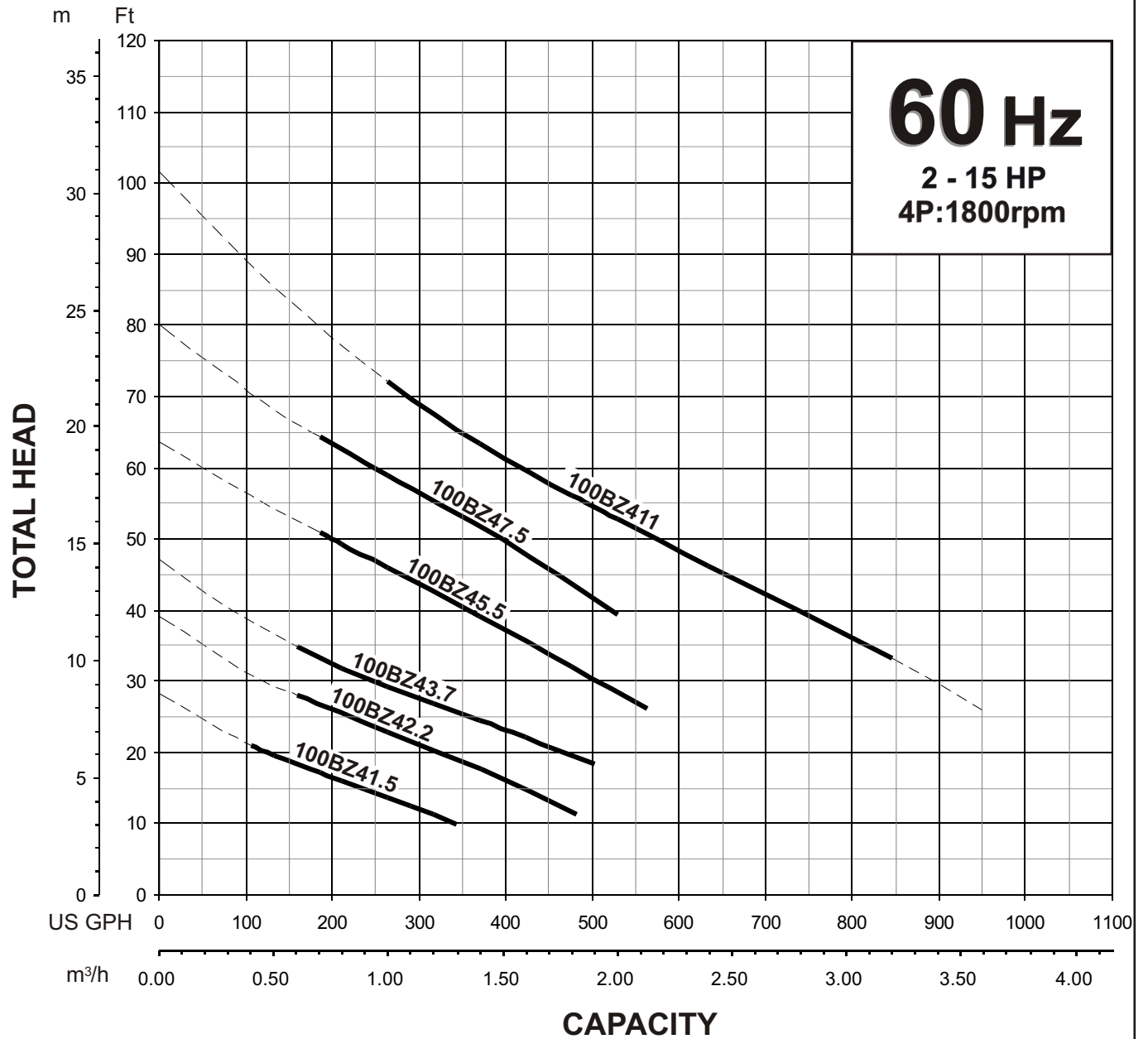

REMARKS: **Not Recommended For
Continuous Operation On Dashed Curve.**



BZ - SERIES

SUBMERSIBLE SEWAGE & WASTEWATER PUMPS

PERFORMANCE
CURVE

MODEL		BORE	HP	KW	RPM	SOLIDS DIA.	LIQUID	SG.	VISCOSITY	TEMP.
(TOS)100BZ43.7-62		4"/100mm	5.0	3.7	1690	3.15"/80mm	Water	1.0	1.123cSt.	60°F
PUMP TYPE		PHASE	VOLTAGE		AMPERAGE		HZ	STARTING METHOD		INS. CLASS
Sewage & Wastewater		3	208-230/460/575		15.0-14.2/7.3/5.4		60	Direct On Line		F
CURVE No.	DATE	PHASE	VOLTAGE		AMPERAGE		HZ	STARTING METHOD		INS. CLASS
-	-	-	-		-		-	-		-

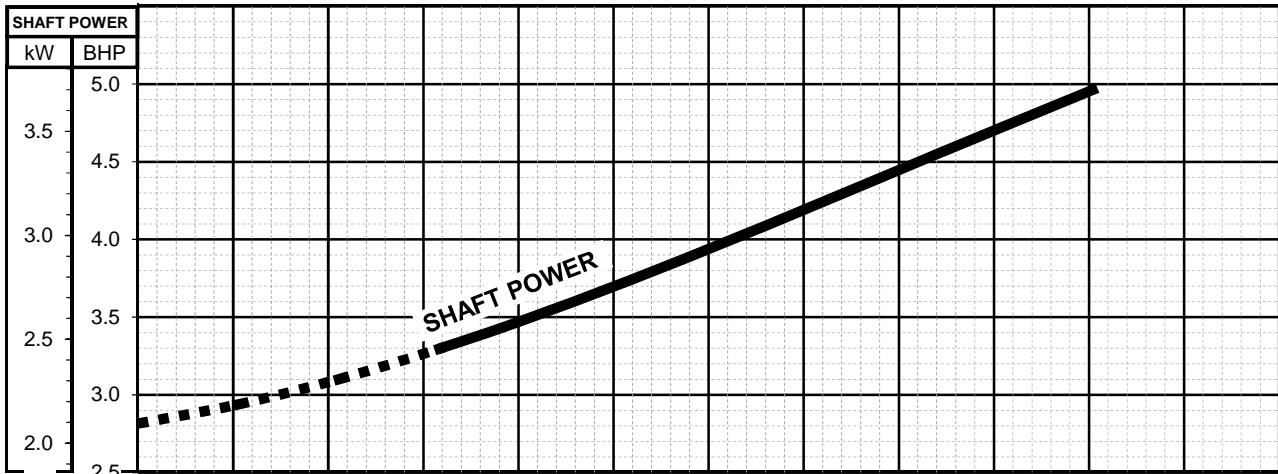
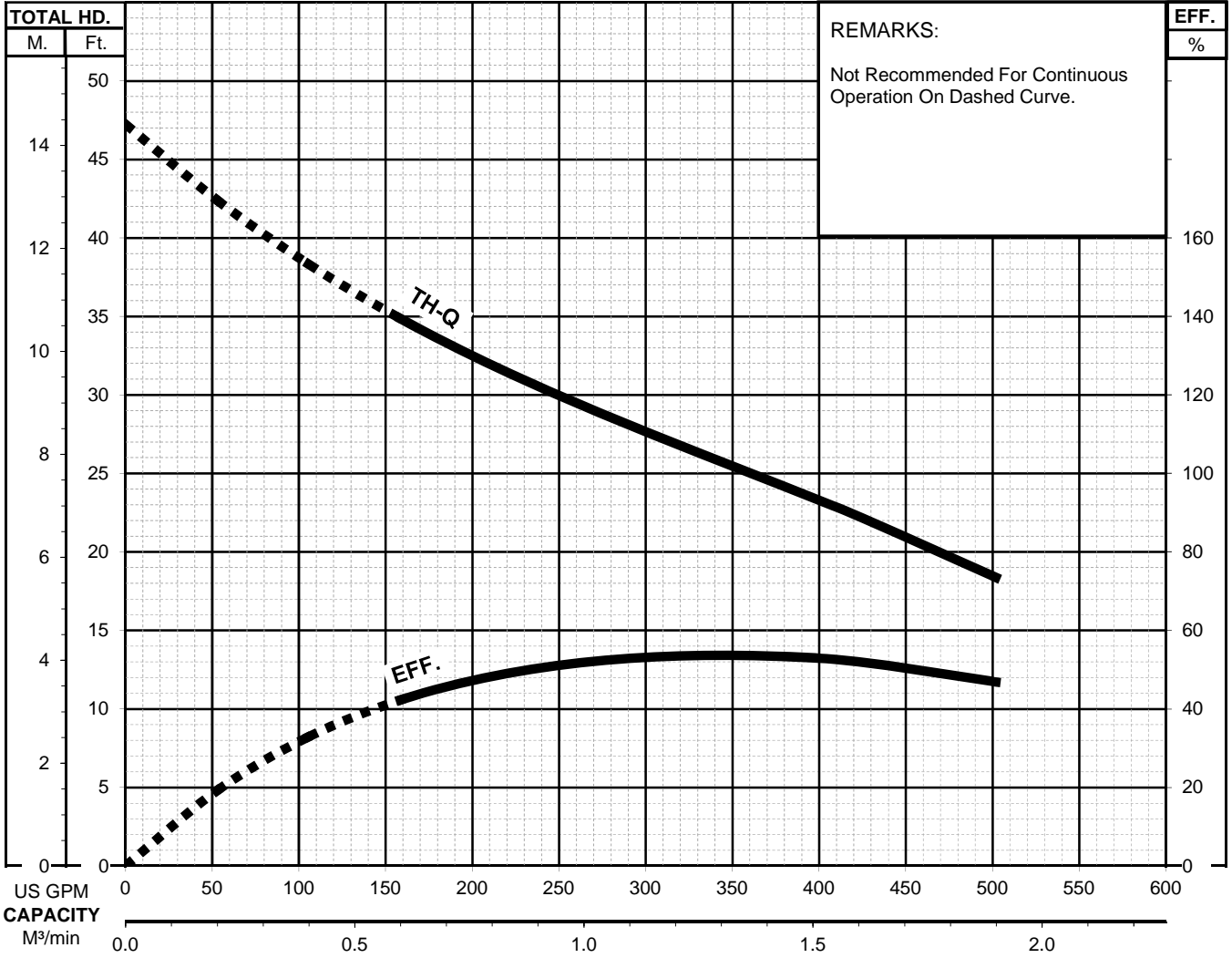



BZ-SERIES
SEWAGE & WASTEWATER PUMPS

SECTIONAL VIEW

100BZ41.5 -62
100BZ42.2 -62
100BZ43.7 -62

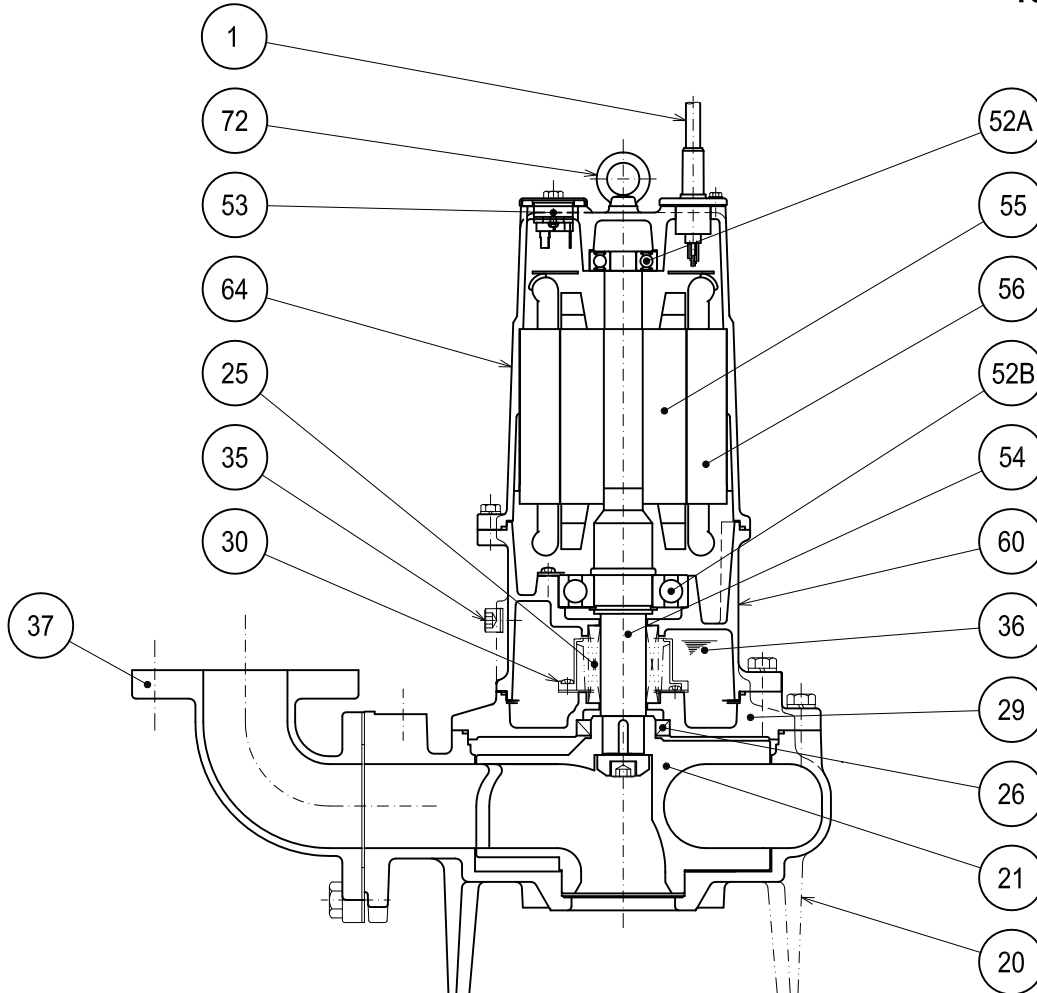

	BZ41.5	BZ42.2	BZ43.7
* 1	AWG 16/4-32ft	AWG 14/4-32ft	AWG 12/4-32ft
* 2	H-30A	H-30A	H-35A
* 3	TC456812	TC456812	TC507212
* 4	#6307ZZC3	#6307ZZC3	#6309ZZC3

PART#	DESCRIPTION	MAIN MATERIAL / NOTE	RELATED ASTM,AISI CODE	RELATED EN CODE	QTY
1	Power Cable	PVC Sheath * 1			1
20	Pump Casing	Cast Iron	A48M Class30B	EN 1561 GJL-200	1
21	Impeller	Cast Iron	A48M Class30B	EN 1561 GJL-200	1
25	Mechanical Seal	Silicon Carbide / * 2			1
26	Oil Seal	NBR / * 3			1
29	Oil Casing	Cast Iron	A48M Class30B	EN 1561 GJL-200	1
30	Oil Lifter	PBT Plastic W/(GF+MD)40			1
35	Oil Plug	Stainless Steel	S 30400	1.4301	1
36	Lubricant	Turbine Oil ISO VG32 or SAE 10W-20			
37	Discharge Bend	Cast Iron / 4"ANSI Flange(150PSI)	A48M Class30B	EN 1561 GJL-200	1
52A	Upper Bearing	AC-#6304ZZC3			1
52B	Lower Bearing	* 4			1
53	Motor Protector				1
54	Shaft	Stainless Steel	S 42000	1.4028	1
55	Rotor				1
56	Stator				1
60	Bearing Housing	Cast Iron	A48M Class30B	EN 1561 GJL-200	1
64	Motor Housing	Cast Iron	A48M Class30B	EN 1561 GJL-200	1
72	Lifting Lug Bolt	Stainless Steel	S 30400	1.4301	2



BZ-SERIES
SEWAGE & WASTEWATER PUMPS

DIMENSIONS

TOS100BZ43.7 -61

Guide Rail System
Model : TOS3-80-100 ANSI
Wt. : 68lb. (31kg)

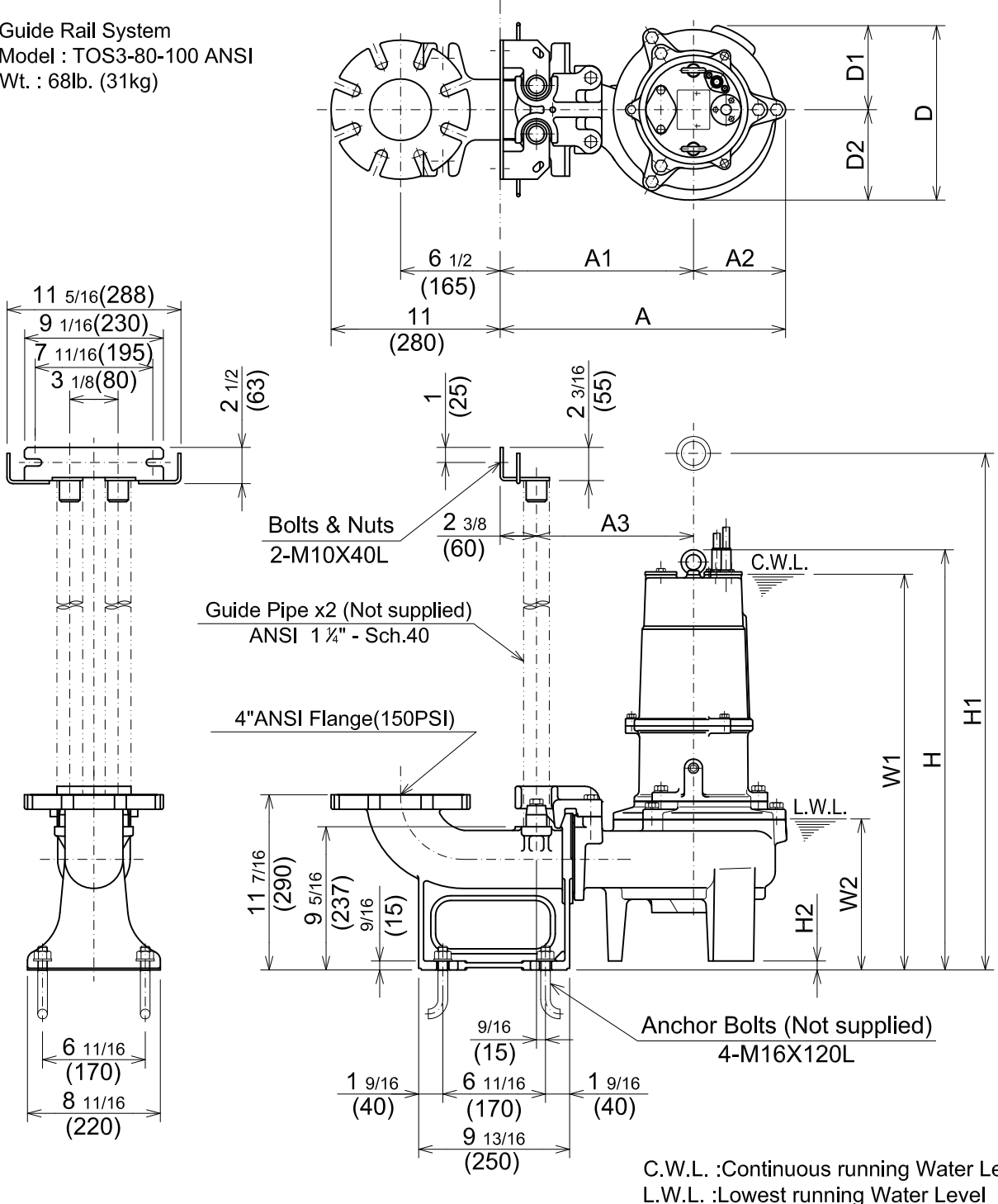

DIMENSIONS:USCS(Inch)

Model	HP	NOM. SIZE	Pump & Motor									C.W.L.	L.W.L.	*Wt. (lbs.)	
			A	A1	A2	A3	D	D1	D2	H	H1				H2
TOS100BZ43.7 -61	5	4"	18 5/8	12 5/8	6	10 1/4	11 3/8	5 1/2	5 7/8	27 3/8	32 3/16	9/16	25 3/4	9 7/8	207

DIMENSIONS:METRIC(mm)

Model	kW	NOM. SIZE	Pump & Motor									C.W.L.	L.W.L.	*Wt. (kg)	
			A	A1	A2	A3	D	D1	D2	H	H1				H2
TOS100BZ43.7 -61	3.7	100	473	320	153	260	289	139	150	696	817	15	655	250	94

*Excluding TOS & Cable.



BZ - SERIES SEWAGE & WASTEWATER PUMPS

SAMPLE SPECIFICATIONS

1. SCOPE OF SUPPLY -

Furnish and install TSURUMI Model _____ Submersible Pump(s). Each unit shall be capable of delivering _____ GPM (_____ m³/min) at _____ Feet (_____ m) TDH. The pump(s) shall be designed to pump waste water, sewage or effluent containing _____ inch (_____ mm) diameter solids without damage during operation. The pump(s) shall be designed so that the shaft power required (BHP)/(kW) shall not exceed The motor rated output throughout the entire operating range of the pump performance curve. The pump discharge size shall be _____ inch, (_____ mm).

2. MATERIALS OF CONSTRUCTION -

Construction of major parts of the pumping unit(s) including pump casing, impeller, and discharge elbow shall be manufactured from gray cast iron, ASTM A48 CLASS 35. Unit(s) shall have a field adjustable and or replaceable, cast iron wear plate or wear rings. Internal and external surfaces coming into contact with the pumpage shall be protected by a fused polymer coating. All exposed fasteners shall be stainless steel. All units shall be furnished with a discharge elbow with 150 lb. (10 kg/cm²) flat face flange and NPT companion flange. Impellers shall be of the single vane, enclosed, solids handling design equipped with back pump out vanes and shall be slip fit to the shaft and key driven. The pump casing shall incorporate an air relief valve.

3. MECHANICAL SEAL -

All units shall be furnished with a dual inside mechanical shaft seal located completely out of the pumpage, running in a separate oil filled chamber and further protected by an exclusionary oil seal located between the bottom seal faces and the fluid being pumped. The oil chamber shall be fitted with a device that shall provide positive lubrication of top mechanical seal, (down to one third of the standard oil level). The device shall not consume any additional electrical power. Mechanical seals shall rated to preclude the incursion of water up to 42.6 PSI. (98.4 Ft.). Units shall have silicon carbide mechanical seal faces. Mechanical seal hardware shall be stainless steel.

4. MOTOR -

The pump motor(s) shall be _____ Hp., _____ kW., _____ V., 60 Hz., 3 Phase and shall be NEMA MG-1, Design Type B equivalent. Motor(s) shall be rated at _____ full load amps. Motor(s) shall have a 1.15 service factor and shall be rated for 20 starts per hour. Motor(s) shall be air filled, copper wound, class F insulated with built in thermal protection for each winding. Motor shaft shall be 420 or 403 stainless steel and shall be supported by two permanently lubricated, high temperature ball bearings, with a B-10 life rating at best efficiency point of 60,000 hours. On units up to 10 Hp. (7.5 kW), the bottom bearing shall be single row, double shielded, C3, deep groove type ball bearings. On units 15 Hp. (11 kW), the bottom bearing shall be two row, double shielded, C3, deep groove type ball bearings. The top bearing on all units shall be single row, double shielded, C3, deep groove type ball bearings. Motor housing and bearing housing shall be gray cast iron, ASTM A48 CLASS 30. Motors shall be D.O.L. or Star-delta start (15 Hp.), and shall be suitable for across the line start or variable speed applications, utilizing a properly sized variable frequency drive.

5. POWER CABLE AND CABLE ENTRANCE -

The pump power cable shall be suitable for submersible pump applications. Units up to 5 Hp. shall be supplied with a cable entrance that incorporates built in strain relief, a one piece, three way mechanical compression seal with a fatigue reducing cable boot. On units 7.5 Hp. and above, the cable entrance shall incorporate built in strain relief, and combination three way mechanical compression sealing with a fatigue reducing/thermal expansion rubber boot. The power cable shall be field replaceable utilizing standard submersible pump cable. The cable entrance assembly on all units shall contain an anti-wicking block to eliminate water incursion into the motor due To capillary wicking should the power cable be accidentally damaged.