



BZ - SERIES

SINGLE VANE - SEWAGE & WASTE WATER PUMPS

SPECIFICATIONS

■ FEATURES

1. Single Vane, Cast Iron, impeller passes 3" diameter solids without clogging providing for highly efficient pumping of raw sewage and waste water.
2. Double inside mechanical seals with silicon carbide faces, running in an oil filled chamber and further protected by a lip seal, provides for the most durable seal design available.
3. Highly efficient, continuous duty, air filled, copper wound motor with class F, insulation minimizes the cost of operation.
4. Built in thermal & amperage sensing, protector prevents motor failure due to overloading, single phasing (in three phase units), or accidental run -dry conditions.
5. Double shielded, permanently lubricated, high temperature C3 ball bearings rated for a B-10 life of 60,000 hours, extend operational life.

■ APPLICATIONS

1. Residential, commercial, industrial sewage, effluent, wastewater and site drainage.
2. Decorative waterfalls, fountains and fish ponds.
3. Raw water supply from rivers or lakes.



■ SPECIFICATIONS

Discharge Size
 Horsepower Range
 Performance Range Capacity
 Head
 Maximum water temperature
 Materials of Construction
 Casing
 Impeller
 Shaft
 Motor Frame
 Fasteners

 Mechanical Seal
 Elastomers

 Impeller Type
 Solids Handling Capability

 Bearings

 Motor Nomenclature
 Type, Speed, Hz.
 Voltage, Phase

 Insulation

 Accessories
 Operational Mode

■ STANDARD

4" Npt (100 mm)
 2 ~15 Hp. (1.5 ~ 11 kW)
 105.7 ~ 951.0 Gpm. (.40 ~ 3.60 m³/min)
 21.0 Ft. ~ 101.7Ft. (6.4 ~ 31.0 m)
 104° F. (40° C.)

 ASTM 48 Class 35 Cast Iron
 ASTM 48 Class 35 Cast Iron
 420,403 Stainless Steel
 ASTM 48 Class 35 Cast Iron
 304 Stainless Steel

 Silicon Carbide
 NBR (Nitril Buna Rubber)

 Enclosed Single Vane, solids handling.
 3.15" (80 mm)

 Pre-lubricated, Double Shielded

 Air Filled, 1800 Rpm, 60 Hz.
 208-230, 230 or 440, 460 or 575 V.
 (3 Phase)

 Class F
 Submersible Power Cable 32' (10 m)
 Manual

■ OPTIONS

Nema 3R inverter available for
 230 V.,1 Ph. operation from
 2~5 Hp.

 Length as Required

 Model
 TOS Slide rail system



BZ - SERIES (12" base pump)

SEWAGE & WASTEWATER PUMPS

PERFORMANCE RANGE

GROUP PERFORMANCE RANGE

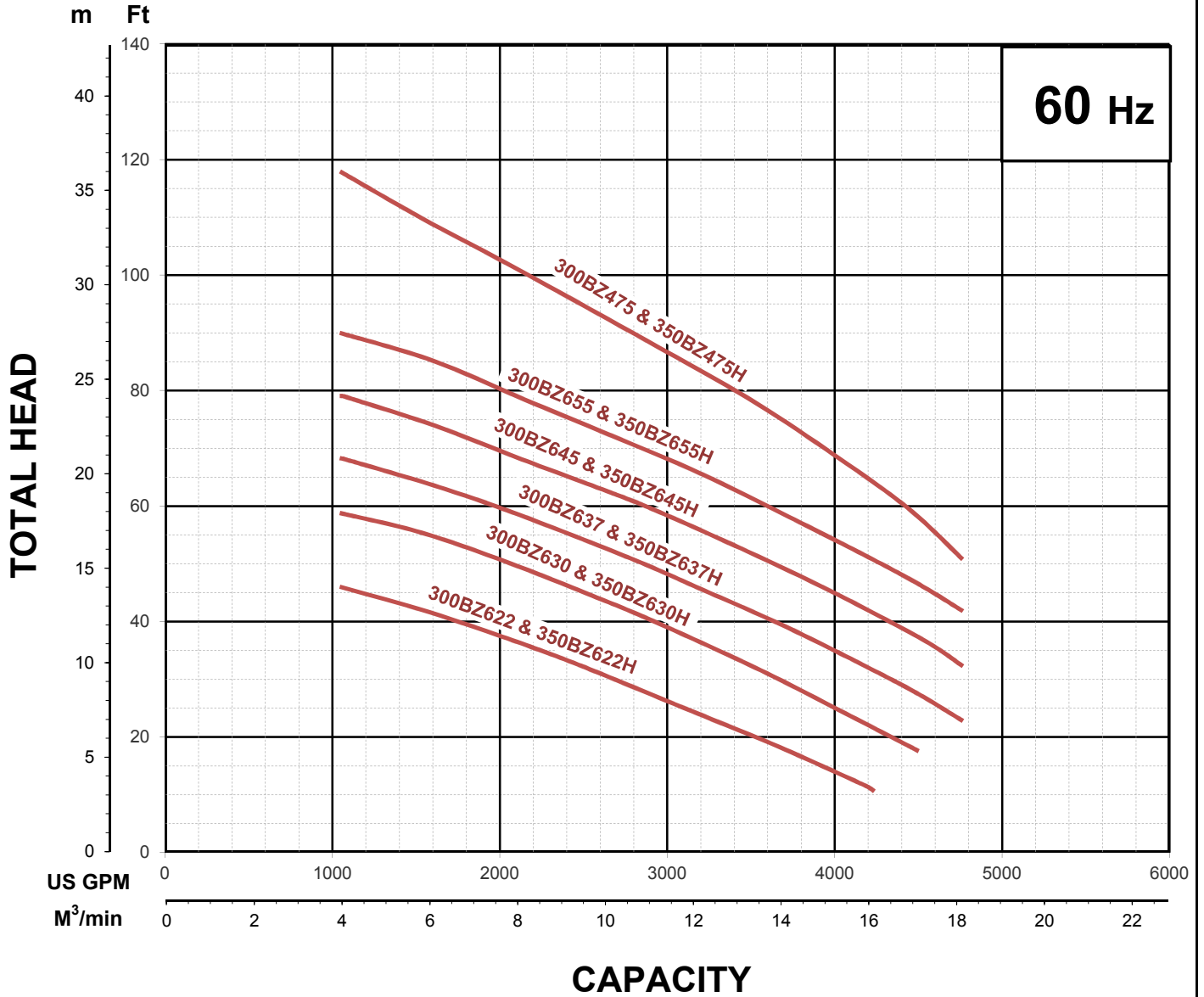

Note



BZ - SERIES

SEWAGE & WASTEWATER PUMPS

PERFORMANCE CURVE

MODEL	BORE	HP	kW	RPM	SOLIDS DIA.	LIQUID	SG.	VISCOSITY	TEMP.
(TO)300BZ475 -61	12"/300mm	100	75	SS 1800	3.54"/90mm	Water	1.0	1.123cSt.	60°F
PUMP TYPE		PHASE	VOLTAGE	AMPERAGE	HZ	STARTING METHOD		INS. CLASS	
Sewage & Wastewater Pump		3	460 / 575	- / -	60	Star-Delta		F	
CURVE No.	DATE	PHASE	VOLTAGE	AMPERAGE	HZ	STARTING METHOD		INS. CLASS	
-	-	-	-	-	-	-		-	

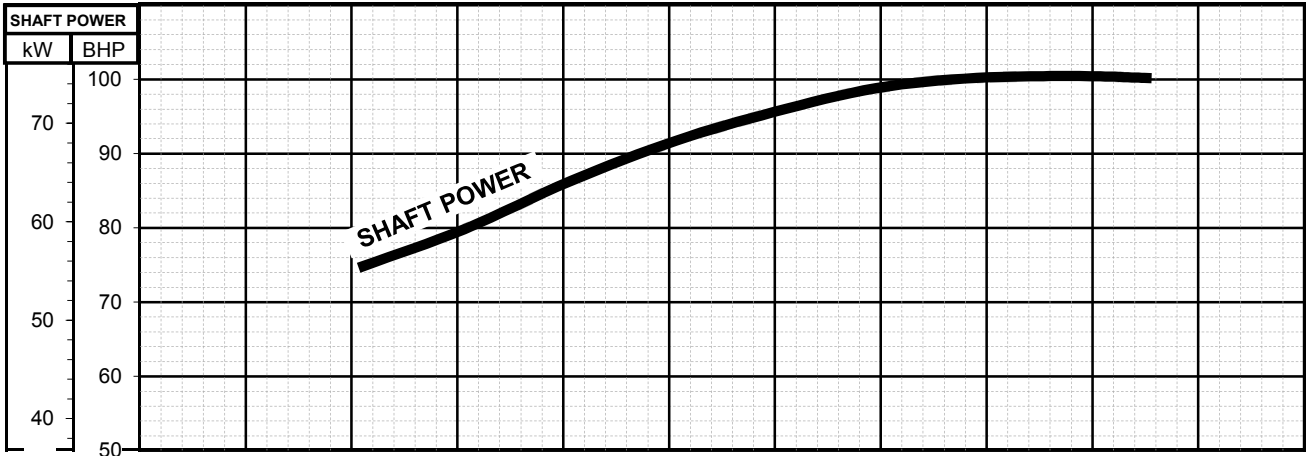
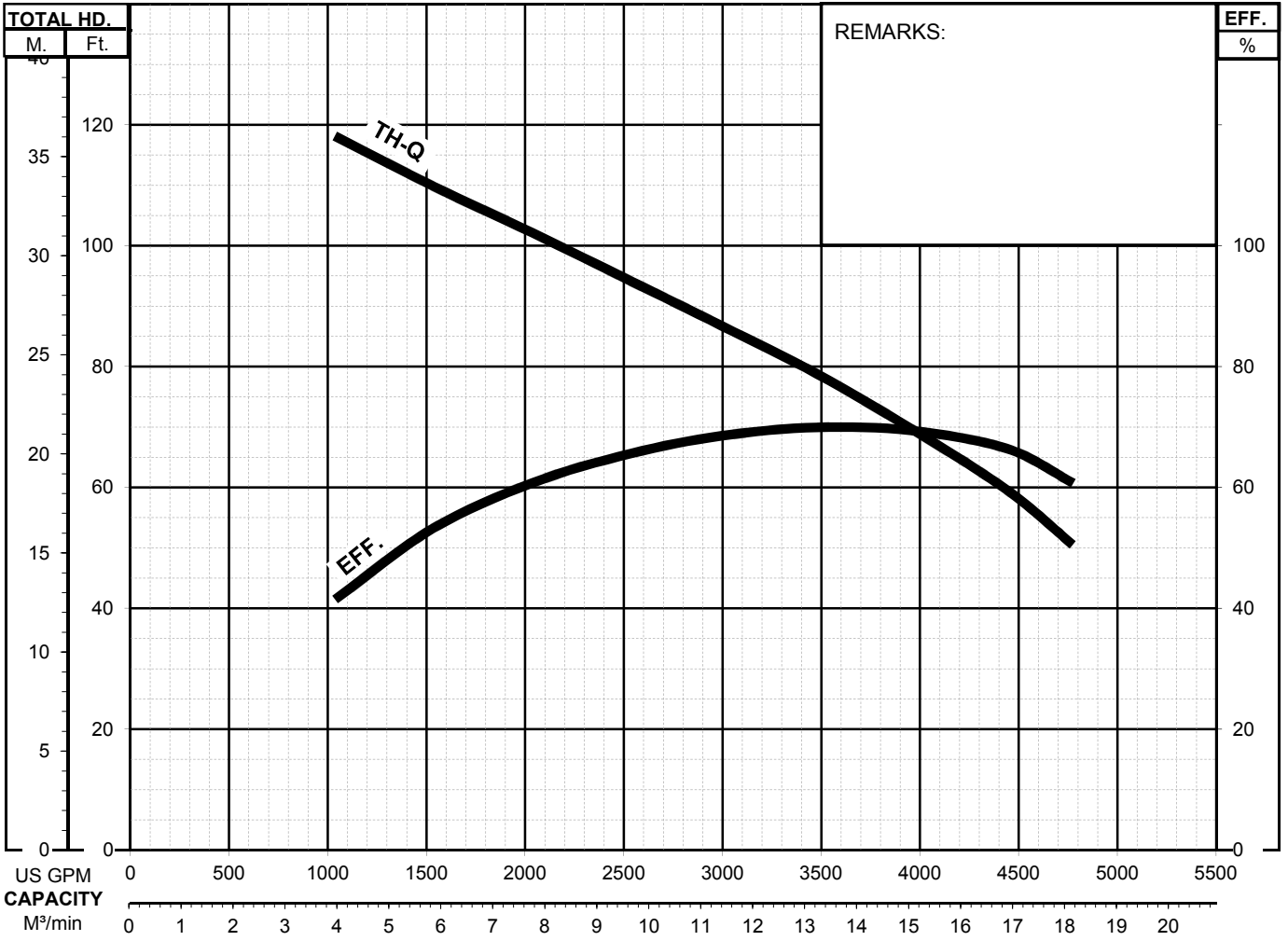

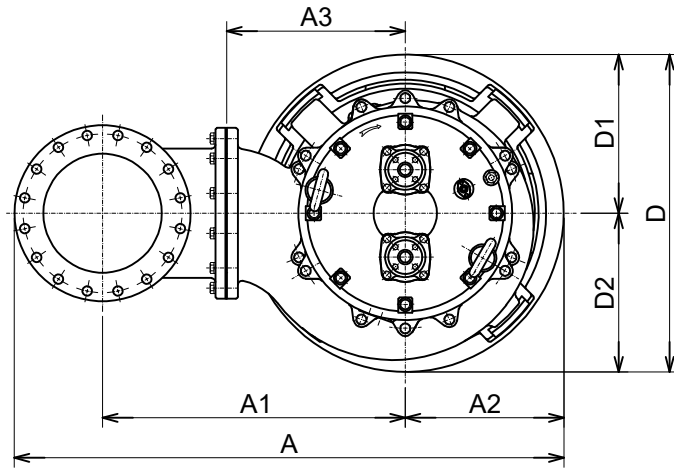

300BZ645 -61
300BZ655 -61
300BZ475 -61

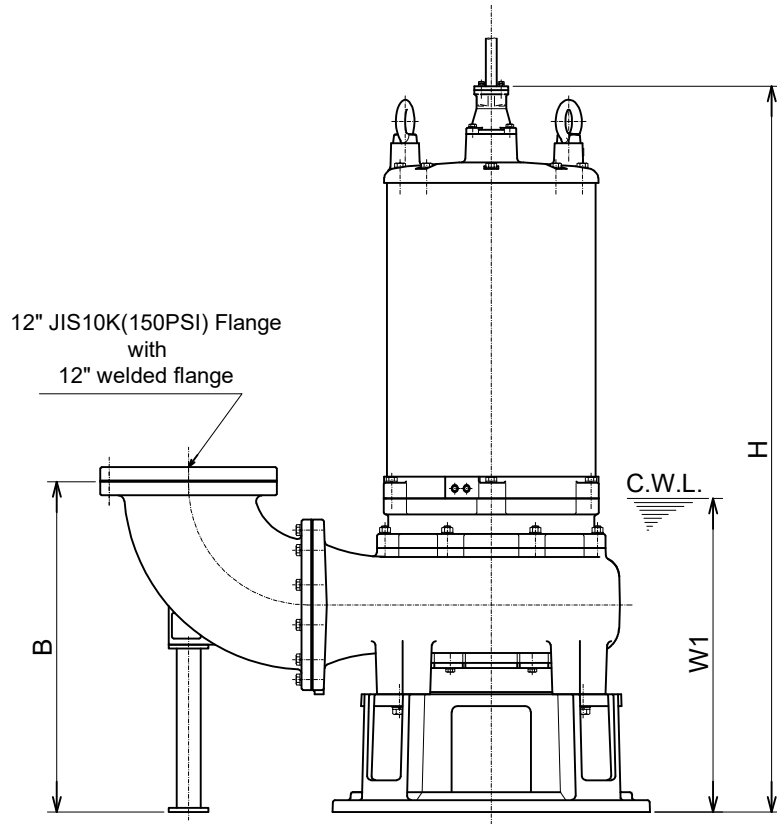

C.W.L. :Continuous running Water Level

DIMENSIONS:USCS (Inch)

Model	HP	NOM. SIZE	Pump & Motor									C.W.L. W1	*Wt. (lbs.)
			A	A1	A2	A3	B	D	D1	D2	H		
300BZ645-61	60	12"	54 9/16	30 1/16	15 3/4	17 11/16	32 3/4	31 1/2	15 3/4	15 3/4	72 5/8	31 1/8	2670
300BZ655-61	75	12"	54 9/16	30 1/16	15 3/4	17 11/16	32 3/4	31 1/2	15 3/4	15 3/4	72 5/8	31 1/8	2670
300BZ475-61	100	12"	54 9/16	30 1/16	15 3/4	17 11/16	32 3/4	31 1/2	15 3/4	15 3/4	72	31 1/8	2730

DIMENSIONS:METRIC (mm)

*Excluding Cable

Model	kW	NOM. SIZE	Pump & Motor									C.W.L. W1	*Wt. (kg)
			A	A1	A2	A3	B	D	D1	D2	H		
300BZ645-61	45	300	1386	763	400	450	832	800	400	400	1845	790	1210
300BZ655-61	55	300	1386	763	400	450	832	800	400	400	1845	790	1210
300BZ475-61	75	300	1386	763	400	450	832	800	400	400	1829	790	1240

TO300BZ645 -61
TO300BZ655 -61
TO300BZ475 -61

Guide rail
Model: TO-300
Weight: 595 lbs. (270kg)

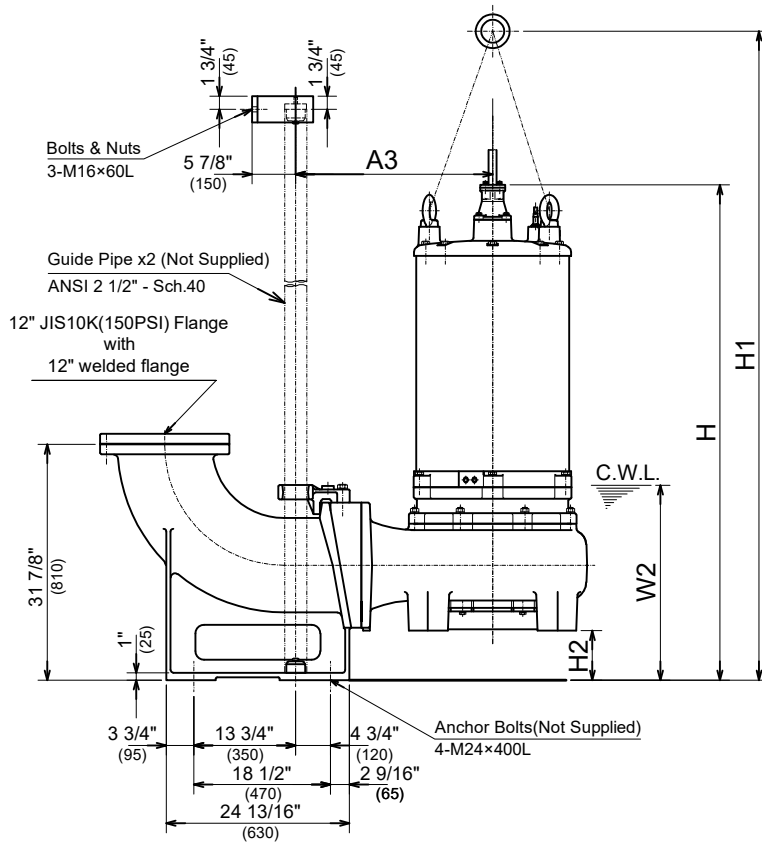
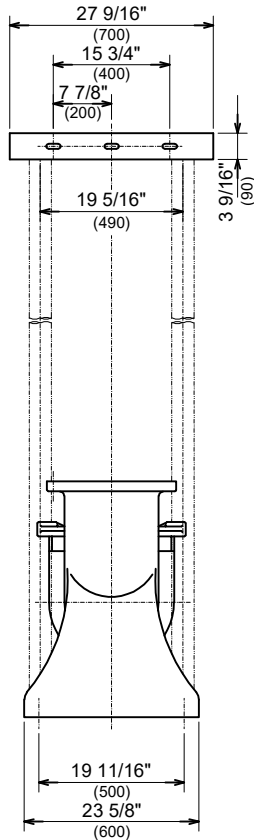
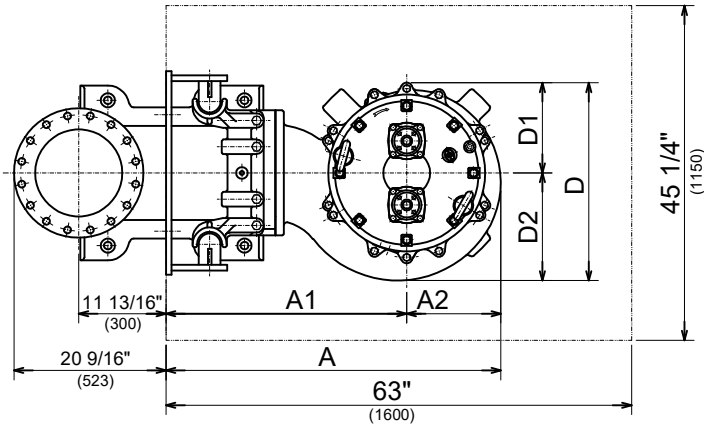

C.W.L. :Continuous running Water Level

DIMENSIONS:USCS (Inch)

Model	HP	NOM. SIZE	Pump & Motor										C.W.L. W1	*Wt. (lbs.)
			A	A1	A2	A3	D	D1	D2	H	H1	H2		
TO300BZ645 -61	60	12"	45 5/16	32 9/16	12 3/4	26 5/8	26 3/4	12 1/4	14 9/16	67 5/8	89	6 11/16	26 3/8	2450
TO300BZ655 -61	75	12"	45 5/16	32 9/16	12 3/4	26 5/8	26 3/4	12 1/4	14 9/16	67 5/8	89	6 11/16	26 3/8	2450
TO300BZ475 -61	100	12"	45 5/16	32 9/16	12 3/4	26 5/8	26 3/4	12 1/4	14 9/16	67	87 13/16	6 11/16	26 3/8	2510

DIMENSIONS:METRIC (mm)

*Excluding TOS & Cable

Model	kW	NOM. SIZE	Pump & Motor										C.W.L. W1	*Wt. (kg)
			A	A1	A2	A3	D	D1	D2	H	H1	H2		
TO300BZ645 -61	45	300	1151	827	324	677	680	310	370	1718	2261	170	670	1110
TO300BZ655 -61	55	300	1151	827	324	677	680	310	370	1718	2261	170	670	1110
TO300BZ475 -61	75	300	1151	827	324	677	680	310	370	1702	2231	170	670	1140

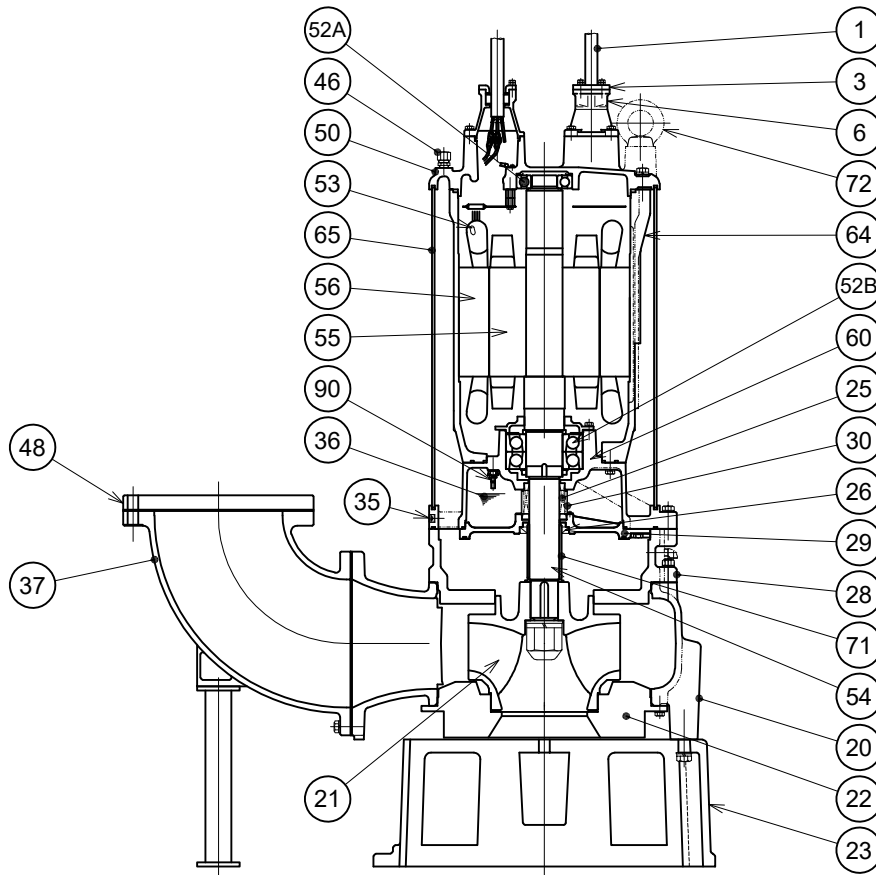

300BZ645 -61
300BZ655 -61
300BZ475 -61

PART#	DESCRIPTION	MAIN MATERIAL / NOTE	RELATED ASTM, AISI CODE	RELATED EN CODE	QTY
1	Power Cable	45&55kW: Chloroprene Sheath AWG 6/4 - 32ft			1
		45&55kW: Chloroprene Sheath AWG 6/3 - 32ft			1
		75kW: Chloroprene Sheath AWG 4/4 - 32ft			1
		75kW: Chloroprene Sheath AWG 4/3 - 32ft			1
	Control Cable	PVC Sheath AWG 16/3 - 32ft			1
3	Gland	Cast Iron	A48M Class30B	EN 1561 GJL-200	2
6	Staffing Box	Cast Iron	A48M Class30B	EN 1561 GJL-200	2
20	Pump Casing	Cast Iron	A48M Class35B	EN 1561 GJL-250	1
21	Impeller	Cast Iron	A48M Class35B	EN 1561 GJL-250	1
22	Suction Cover	Cast Iron	A48M Class35B	EN 1561 GJL-250	1
23	Strainer Stand	Cast Iron	A48M Class30B	EN 1561 GJL-200	1
25	Mechanical Seal	Silicon Carbide / H-70			1
26	Oil Seal	NBR / TC8011515			1
28	Middle Plate	Cast Iron	A48M Class35B	EN 1561 GJL-250	1
29	Oil Casing	Cast Iron	A48M Class30B	EN 1561 GJL-200	1
30	Oil Lifter	Steel (Cold Rolled)	A109/A1008	EN 10130	1
35	Oil Plug	Stainless Steel	S30400	1.4301	2
36	Lubricant	Turbine Oil ISO VG32 or SAE10W-20			
37	Discharge Bend	Cast Iron	A48M Class30B	EN 1561 GJL-200	1
46	Air Valve	Steel (Cold Rolled)	A109/A1008	EN 10130	1
48	Welded Flange	Steel / 12"	A283 Grade D	EN 10025 S275	1
50	Motor Bracket	Cast Iron	A48M Class30B	EN 1561 GJL-200	1
52A	Upper Bearing	45&55kW: #6313ZZC3 / 75kW: #6312ZZC3			1
52B	Lower Bearing	45&55kW: #7318BDB / 75kW: #7317DBD			1
53	Motor Protector				3
54	Shaft	Stainless Steel	S42000	1.4028	1
55	Rotor				1
56	Stator				1
60	Bearing Housing	Cast Iron	A48M Class30B	EN 1561 GJL-200	1
64	Motor Housing	Cast Iron	A48M Class30B	EN 1561 GJL-200	1
65	Outer Cover	Steel	A283 Grade D	EN 10025 S275	1
71	Shaft Sleeve	Stainless Steel	S40300	1.4000	1
72	Lifting Lug Bolt	Steel	A283 Grade D	EN 10025 S275	2
90	Leakage Sensor (Electrode)	Stainless Steel			1

TSURUMI PUMP
**BZ - SERIES
SEWAGE & WASTEWATER PUMPS**
**SAMPLE
SPECIFICATIONS**

1. SCOPE OF SUPPLY -

Furnish and install TSURUMI Model _____ Submersible Pump(s). Each unit shall be capable of delivering _____ GPM (_____ m³/min) at _____ Feet (_____ m) TDH. The pump(s) shall be designed to pump waste water, sewage or effluent containing _____ inch (_____ mm) diameter solids without damage during operation. The pump(s) shall be designed so that the shaft power required (BHP)/(kW) shall not exceed The motor rated output throughout the entire operating range of the pump performance curve. The pump discharge size shall be _____ inch, (_____ mm).

2. MATERIALS OF CONSTRUCTION -

Construction of major parts of the pumping unit(s) including pump casing, impeller, and discharge elbow shall be manufactured from gray cast iron, ASTM A48 CLASS 30B. Unit(s) shall have a field adjustable and or replaceable, cast iron wear plate or wear rings. Internal and external surfaces coming into contact with the pumpage shall be protected by a fused polymer coating. All exposed fasteners shall be stainless steel. All units shall be furnished with a discharge elbow with 150 lb. (10 kg/cm²) flat face flange and NPT companion flange. Impellers shall be of the single vane, enclosed, solids handling design equipped with back pump out vanes and shall be slip fit to the shaft and key driven. The pump casing shall incorporate an air relief valve.

3. MECHANICAL SEAL -

All units shall be furnished with a dual inside mechanical shaft seal located completely out of the pumpage, running in a separate oil filled chamber and further protected by an exclusionary oil seal located between the bottom seal faces and the fluid being pumped. The oil chamber shall be fitted with a device that shall provide positive lubrication of top mechanical seal, (down to one third of the standard oil level). The device shall not consume any additional electrical power. Mechanical seals shall rated to preclude the incursion of water up to 42.6 PSI. (98.4 Ft.). Units shall have silicon carbide mechanical seal faces. Mechanical seal hardware shall be stainless steel.

4. MOTOR -

The pump motor(s) shall be _____ Hp., _____ kW., _____ V., 60 Hz., 3 Phase and shall be NEMA MG-1, Design Type B equivalent. Motor(s) shall be rated at _____ full load amps. Motor(s) shall have a 1.15 service factor and shall be rated for 20 starts per hour. Motor(s) shall be air filled, copper wound, class E or F (7.5 Hp. and above) insulated with built in thermal protection for each winding. Motor shaft shall be 420 or 403 stainless steel and shall be supported by two permanently lubricated, high temperature ball bearings, with a B-10 life rating at best efficiency point of 60,000 hours. On units up to 10 Hp. (7.5 kW), the bottom bearing shall be single row, double shielded, C3, deep groove type ball bearings. On units 15 Hp. (11 kW), the bottom bearing shall be two row, double shielded, C3, deep groove type ball bearings. The top bearing on all units shall be single row, double shielded, C3, deep groove type ball bearings. Motor housing and bearing housing shall be gray cast iron, ASTM A48 CLASS 25B or 30B (7.5 Hp. and above). Motors shall be D.O.L. or Star-delta start (15 Hp.), and shall be suitable for across the line start or variable speed applications, utilizing a properly sized variable frequency drive.

5. POWER CABLE AND CABLE ENTRANCE -

The pump power cable shall be suitable for submersible pump applications. Units up to 5 Hp. shall be supplied with a cable entrance that incorporates built in strain relief, a one piece, three way mechanical compression seal with a fatigue reducing cable boot. On units 7.5 Hp. and above, the cable entrance shall incorporate built in strain relief, and combination three way mechanical compression sealing with a fatigue reducing/thermal expansion rubber boot. The power cable shall be field replaceable utilizing standard submersible pump cable. The cable entrance assembly on all units shall contain an anti-wicking block to eliminate water incursion into the motor due To capillary wicking should the power cable be accidentally damaged.