



**KRS2 - SERIES
HIGH VOLUME - DEWATERING PUMP**

SPECIFICATIONS

■ FEATURES

1. Semi-open, Mixed Flow, impeller, with replaceable adjustable wear plate, increases wear resistance when pumpage contains abrasive particles.
2. Double inside mechanical seals with silicon carbide faces, (both top and bottom) running in an oil filled chamber and further protected by a lip seal running against a replaceable, 430 stainless steel shaft sleeve, provides for the most durable seal design available.
3. Highly efficient, continuous duty air filled, copper wound motor with class E, B, F insulation minimizes the cost of operation.
4. Double shielded, permanently lubricated, high temperature C3 ball bearings, rated for a B-10 life of 60,000 hours, extend operational life.

5. Top discharge, flow-thru design enables operation at low water levels for extended periods.
6. 4 - pole motor increases product life and offers greater convenience.
7. Agitator installed on the motor shaft extension forcibly agitates the fluid for easy and efficient transmission of sludge and slime. (KRS2-80/-100/-150/KRS822L-SK)

■ APPLICATIONS

1. Commercial, industrial wastewater and construction site drainage.
2. Effluent transfer.
3. Decorative waterfalls and fountains.
4. Raw water supply from rivers or lakes.



■ SPECIFICATIONS

- Discharge Size
- Horsepower Range
- Performance Range Capacity Head
- Maximum water temperature
- Materials of Construction
 - Casing
 - Impeller
 - Agitator
 - Shaft
 - Motor Frame
 - Fasteners
- Mechanical Seal
 - Elastomers
- Impeller Type
- Solids Handling Capability
- Bearings
- Motor Nomenclature
 - Type, Speed, Hz.
 - Voltage, Phase
 - Insulation
- Accessories
- Operational Mode

■ STANDARD

- 3 ~ 14" NPT (80 ~ 350 mm)
- 3 ~ 50 HP. (2.2 ~ 37 kW)
- 66.0~4359.0 GPM. (0.25~16.50 m³/min)
- 16.4 ~ 113.0 Ft. (5.0 ~ 34.4 m)
- 104° F. (40° C.)
- Cast Iron
- Ductile Cast Iron , High Chrome Cast Iron (KRS2-80/-100/-150/KRS822L-SK)
- 420 Stainless Steel
- Cast Iron
- 304 Stainless Steel
- Silicon Carbide
- NBR (Nitrile Butadiene Rubber)
- Semi-open , Mixed Flow ,with Agitator
- 0.472 - 1.97" (12.0 - 50.0mm)
- Prelubricated, Double Shielded
- Air Filled, 1800 RPM, 60 Hz.
- 208/230/460/575 V., 3 Phase
- Class E, F, B
- Submersible Power Cable 50' (15.0 m)
- Manual

■ OPTIONS

- Length as Required
- TS-301 Float Switch



KRS - SERIES HIGH VOLUME - DEWATERING & AGITATOR PUMPS

PERFORMANCE RANGE

GROUP PERFORMANCE RANGE

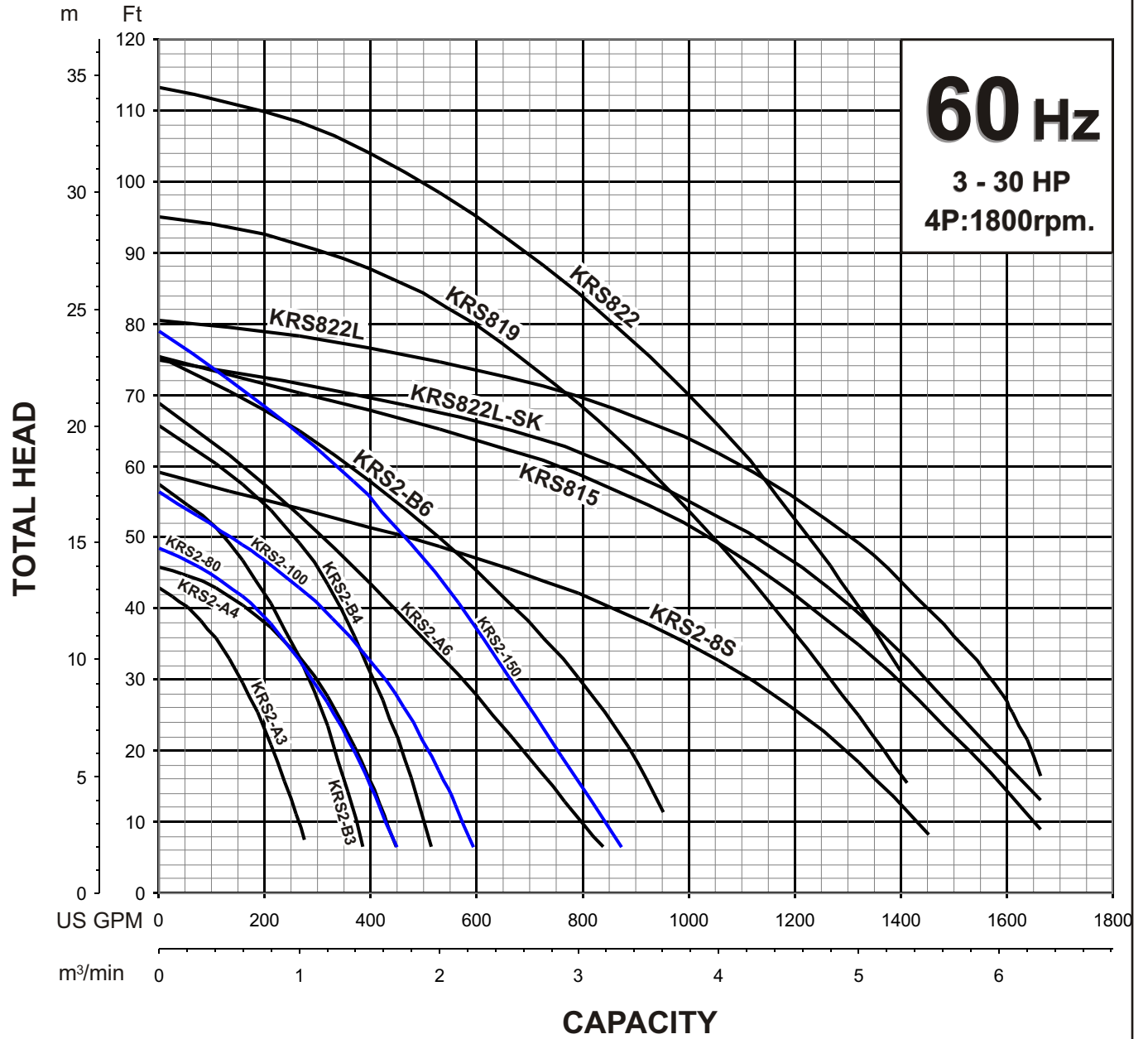



KRS - SERIES HIGH VOLUME - DEWATERING PUMPS

PERFORMANCE CURVE

MODEL	BORE	HP	KW	RPM	SOLIDS DIA	LIQUID	SG.	VISCOSITY	TEMP.
KRS819-61	8"/200mm	25	18.5	1750	0.984"/25mm	Water	1.0	1.123 cSt.	60°F
PUMP TYPE	PHASE	VOLTAGE	AMPERAGE	HZ	STARTING METHOD	INS. CLASS			
High Volume - Dewatering Pump	3	460 / 575	33.0 / 26.4	60	Direct On Line	F			
CURVE No.	DATE	PHASE	VOLTAGE	AMPERAGE	HZ	STARTING METHOD	INS. CLASS		
-	-	-	-	-	-	-	-		

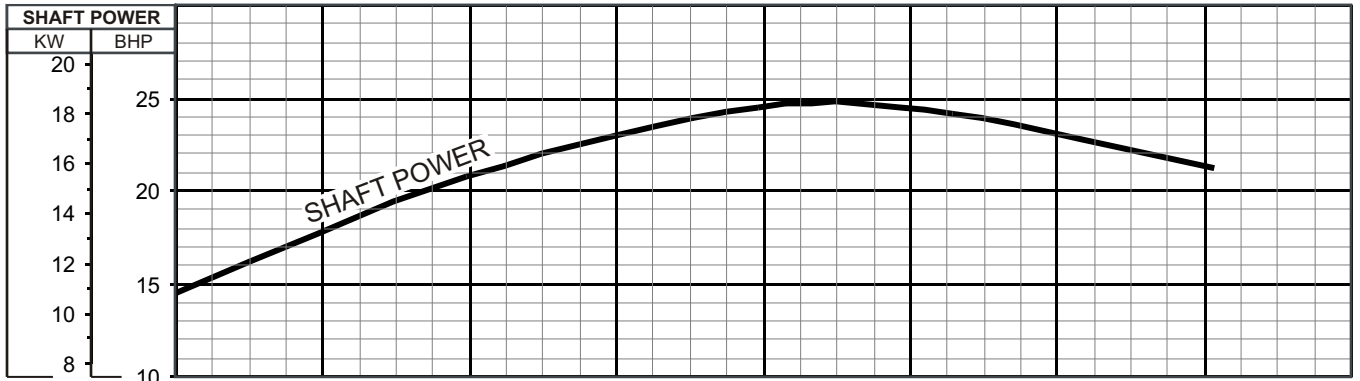
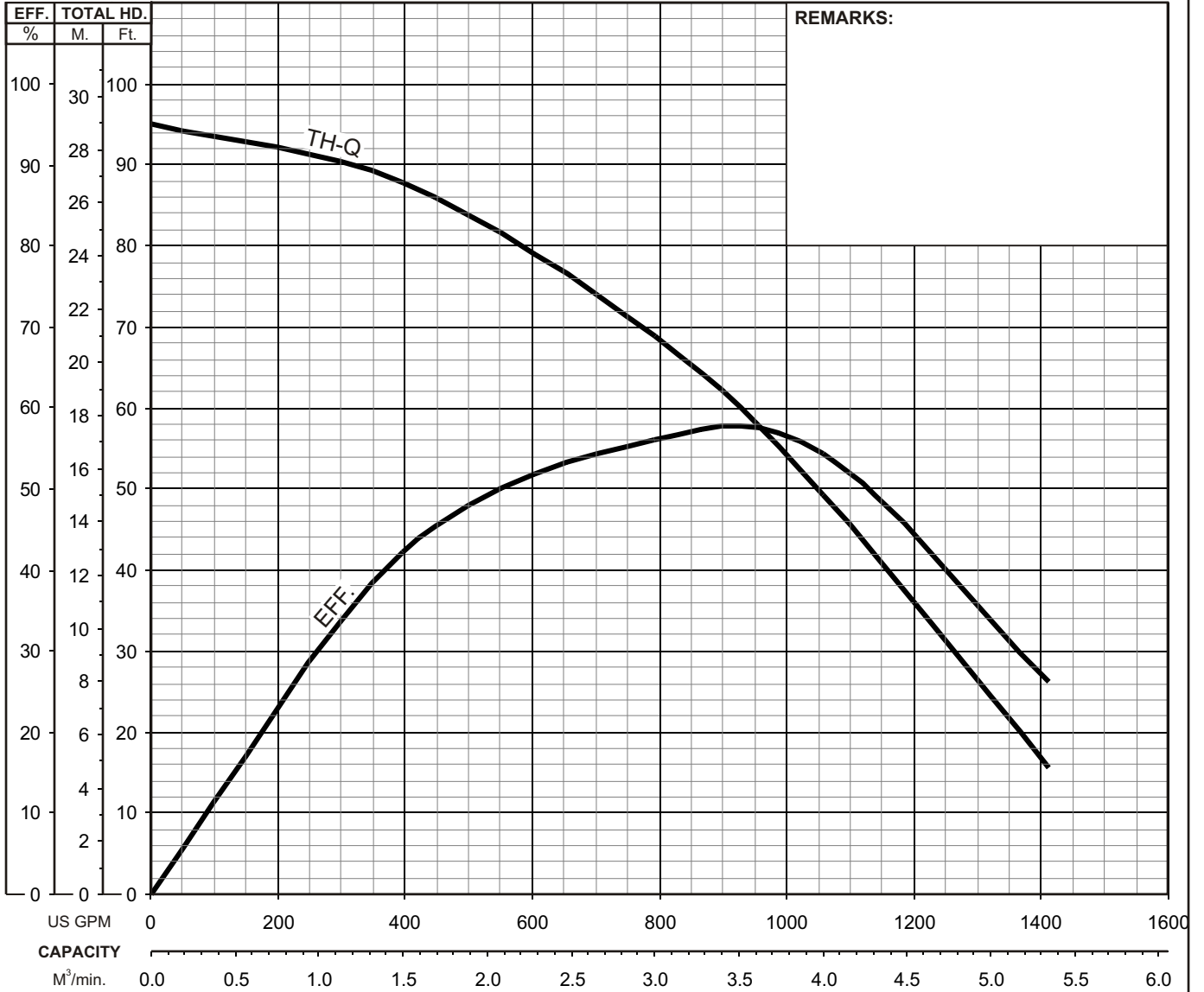



KRS - SERIES
HIGH VOLUME - DEWATERING PUMPS

DIMENSIONS

KRS819-61
KRS822-61
KRS822L-61

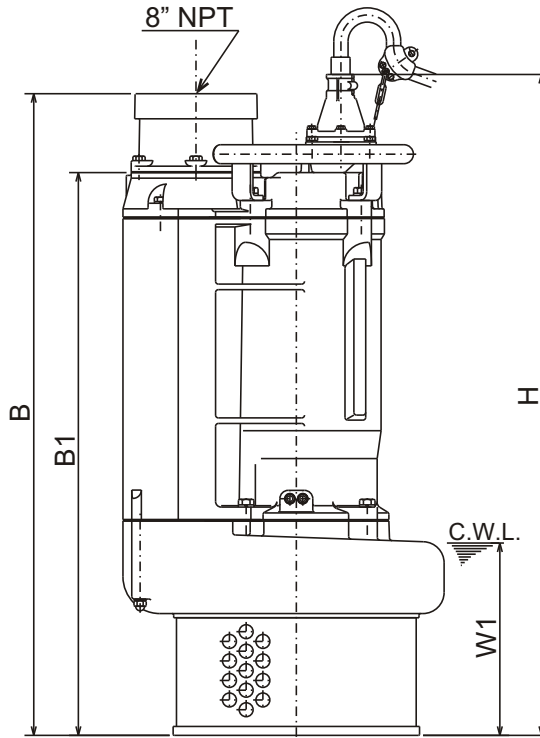
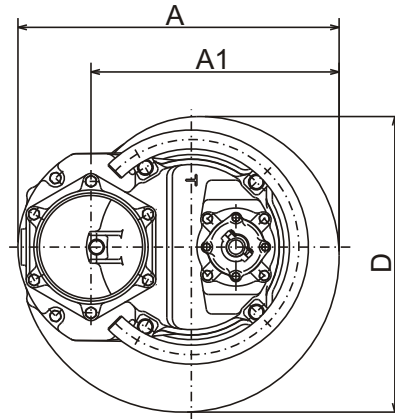

C.W.L. : Continuous running Water Level

DIMENSIONS:USCS (Inch)

Model	HP	NOM. SIZE	Pump & Motor						C.W.L.	*Wt. (lbs.)
			A	A1	B	B1	D	H	W1	
KRS819-61	25	8"	22 11/16	17 1/2	45 5/16	39 3/4	20 7/8	47 1/4	13 5/8	790
KRS822-61	30	8"	22 11/16	17 1/2	45 5/16	39 3/4	20 7/8	47 1/4	13 5/8	840
KRS822L-61	30	8"	22 11/16	17 1/2	45 5/16	39 3/4	20 7/8	47 1/4	13 5/8	840

DIMENSIONS:METRIC (mm)

*Excluding Cable

Model	kW	NOM. SIZE	Pump & Motor						C.W.L.	*Wt. (kg)
			A	A1	B	B1	D	H	W1	
KRS819-61	18.5	200	576	445	1151	1010	530	1200	345	360
KRS822-61	22	200	576	445	1151	1010	530	1200	345	380
KRS822L-61	22	200	576	445	1151	1010	530	1200	345	380



KRS - SERIES
HIGH VOLUME - DEWATERING PUMPS

SECTIONAL VIEW

KRS819-61
KRS822-61
KRS822L-61

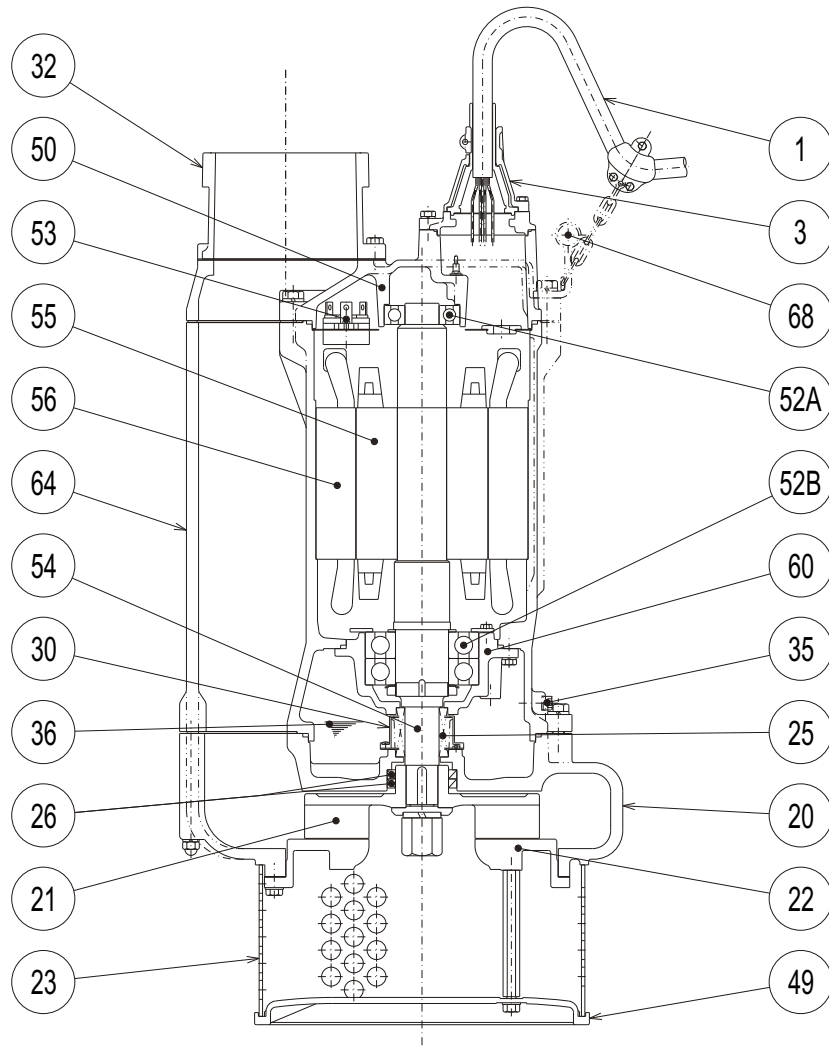

ITEM#	DESCRIPTION	MAIN MATERIAL / NOTE	ASTM, AISI CODE	RELATED DIN CODE	Q'TY
1	Power Cable	Chloroprene Sheath AWG6/4-50ft			1
3	Gland	Cast Iron	A48M Class30B	EN 1561 GJL-199	1
6	Stuffing Box	Cast Iron	A48M Class30B	EN 1561 GJL-200	1
20	Pump Casing	Cast Iron	A48M Class30B	EN 1561 GJL-200	1
21	Impeller	Ductile Cast Iron	A536 100-70-03	EN 1563 GJS-700-2	1
22	Suction Cover	Cast Iron	A48M Class30B	EN 1561 GJL-200	1
23	Suction Strainer	Steel (Cold Rolled)	A109/A1008	EN 10130	1
25	Mechanical Seal	Silicon Carbide / H-45			1
26	Oil Seal	NBR / TC-709212			2
30	Oil Lifter	PBT Plastic W/(GF+MD)40			1
32	Discharge Connection	Cast Iron / NPT 8"	A48M Class30B	EN 1561 GJL-200	1
35	Oil Plug	Stainless Steel	S 30400	1.4301	2
36	Lubricant	Turbine Oil ISO VG32 or SAE 10W-20			
49	Bottom Plate	Ductile Cast Iron	A536 100-70-03	EN 1563 GJS-700-2	1
50	Motor Bracket	Cast Iron	A48M Class30B	EN 1561 GJL-200	1
52A	Upper Bearing	#6309ZZC3			1
52B	Lower Bearing	#6314ZZD2C3			1
53	Motor Protector				1
54	Shaft	Stainless Steel	S 42000	1.4028	1
55	Rotor				1
56	Stator				1
60	Bearing Housing	Cast Iron	A48M Class30B	EN 1561 GJL-200	1
64	Motor Housing	Cast Iron	A48M Class30B	EN 1561 GJL-200	1
68	Handle	Steel Pipe + Steel (Cold Rolled)	A53 Type F + A109/A1008	DIN 1615 St 33 + EN 10130	1



KRS - SERIES HIGH VOLUME - DEWATERING PUMPS

SAMPLE SPECIFICATIONS

1. SCOPE OF SUPPLY -

Furnish and install TSURUMI Model _____ Submersible Pump(s).
Each unit shall be capable of delivering _____ GPM (_____ m³/min) at _____ Feet (_____ m) TDH.
The pumps shall be designed to pump waste water, without damage during operation. The pump(s) shall be designed so that the shaft power required (BHP)/(kW) shall not exceed the motor rated output throughout the entire operating range of the pump performance curve. Pump(s) shall be of the top discharge flow through design.

2. MATERIALS OF CONSTRUCTION -

Construction of major parts of the pumping unit(s) shall be as follows: Pump casing shall be gray cast iron, ASTM A48 CLASS 35. Motor frame shall be gray cast iron. Field adjustable/replaceable wear plate shall be gray cast iron (ASTM A48 CLASS 35) or high chrome cast iron (40 HP and above). Impellers on units up to 30 HP / 8" bore shall be of the multi-vane semi-open design, and shall be ductile cast iron (ASTM A536 100-70-03). Impeller on KRS1022 shall be of the multi-vane enclosed design, and shall be ductile cast iron (ASTM A536 100-70-03). Impellers on KRS-1230/1437 shall be of the multi-vane semi-open design, and shall be high chrome cast iron. Impellers shall be equipped with back pump out vanes, slip fit to the shaft and key driven. Internal and external surfaces coming into contact with the pumpage shall be protected by a fused polymer coating. All exposed fasteners shall be stainless steel. All units shall be furnished with _____" NPT discharge connector.

3. MECHANICAL SEAL -

All units shall be furnished with a dual inside mechanical shaft seal located completely out of the pumpage, running in a separate oil filled chamber and further protected by an exclusionary oil seal located between the bottom seal faces and the fluid being pumped. The oil chamber shall be fitted with a device that shall provide positive lubrication of the top mechanical seal, (down to one third of the standard oil level). The device shall not consume any additional electrical power. Mechanical seals shall be rated to preclude the incursion of water up to 42.6 PSI. (98.4 Ft.) submergence. Units shall be furnished with silicon carbide upper and lower mechanical seal faces. Mechanical seal hardware shall be stainless steel.

4. MOTOR-

The pump motor(s) shall be _____ HP., _____ kW., _____ V., 60 Hz. 3 Phase and shall be NEMA MG-1, Design Type B equivalent. Motor(s) shall be rated at _____ full load amps. Motor(s) shall have a 1.15 service factor and shall be rated for 20 starts per hour. Motor(s) shall be air filled, copper wound, class F, B or E insulated with built in thermal protection for each winding. Motor shaft shall be 420 stainless steel, fitted with a replaceable 403 stainless steel shaft sleeve and shall be supported by two permanently lubricated, high temperature ball bearings, with a B-10 life rating at best efficiency point of 60,000 hours. Bearings on units up to 30 Hp / 8" bore shall be single row, double shielded, C3, deep groove type ball bearing. On units KRS1022 and KRS-1230/1437, the bottom bearing shall be two row, double shielded, C3, deep groove type ball bearing, and the top bearing shall be single row, double shielded, C3, deep groove type ball bearing. Motors shall be D.O.L. or star-delta start (40 and 50 Hp), and shall be suitable for across the line start or variable speed applications, utilizing a properly sized variable frequency drive.

5. POWER CABLE AND CABLE ENTRANCE -

The pump power cable shall be suitable for submersible pump applications and shall be field replaceable utilizing standard submersible pump cable. The cable entrance shall incorporate built in strain relief and a combination three way mechanical compression sealing with a fatigue reducing boot (up to 30 Hp). The cable entrance assembly shall contain an anti-wicking block to eliminate water incursion into the motor due to capillary wicking.