



SFQ - SERIES
ALL 316SS - DEWATERING PUMPS

SPECIFICATIONS

■ FEATURES

1. Semi-open, Cast 316 Stainless steel impeller with field replaceable/adjustable wearplate increases operational life.
2. Double inside mechanical seals with silicon carbide faces, (both top and bottom) and viton elastomers, running in an oil filled chamber and further protected by a exclusionary lip seal, providing for the most durable seal design available. 7.5 ~ 15 Hp models are provided with seal relief ports.
3. Highly efficient, continuous duty air filled, copper wound motor with class E, insulation minimizes the cost of operation.
4. Built in thermal & amperage sensing, protector prevents motor failure due to-

overloading or accidental run -dry conditions.

5. Double shielded, permanently lubricated, high temperature C3 ball bearings rated for a B-10 life of 60,000 hours, extend operational life.
6. Optional TOS All 316 SS Slide rail system is available for models from 7.5 ~ 15 Hp.

■ APPLICATIONS

1. Residential, commercial, industrial wastewater and construction site drainage.
2. Chemical spill containment.
3. Decorative waterfalls, fountains and fish ponds.
4. Raw water supply from rivers or lakes.



■ SPECIFICATIONS

- Discharge Size
- Horsepower Range
- Performance Range Capacity Head
- Maximum water temperature
- Materials of Construction
 - Casing
 - Impeller
 - Shaft
 - Motor Frame
 - Fasteners
- Mechanical Seal Elastomers
- Impeller Type Solids Handling Capability
- Bearings
- Motor Nomenclature
 - Type, Speed, Hz.
 - Voltage, Phase
- Insulation
- Accessories Operational Mode

■ STANDARD

- 2 ~ 4" NPT (50 ~ 100 mm)
- 1 ~ 15 Hp. (.75 ~ 11 kW)
- 27.7 ~ 579.5 GPM (.011 ~ 2.19 m³/min)
- 16.4 Ft. ~ 141.1 Ft. (5.0 ~ 43.0 m)
- 104 °F. (40 °C.)
- 316 Stainless Steel Casting
- 316 Stainless Steel Casting
- 316 Stainless Steel
- 316 Stainless Steel Casting
- 316 Stainless Steel
- Silicon Carbide
- Viton
- Semi-Open, solids handling. .236 ~ .91" (6 ~ 23 mm)
- Pre-lubricated, Double Shielded
- Air Filled, 3600 Rpm, 60 Hz. 208-230, 460 or 575V., 3 (Phase)
- Class E, F
- Submersible Power Cable 32' (10 m)
- Manual

■ OPTIONS

Length as Required



TSURUMI PUMP

SFQ - SERIES
ALL 316 SS- DEWATERING PUMPS

PERFORMANCE RANGE

GROUP PERFORMANCE RANGE

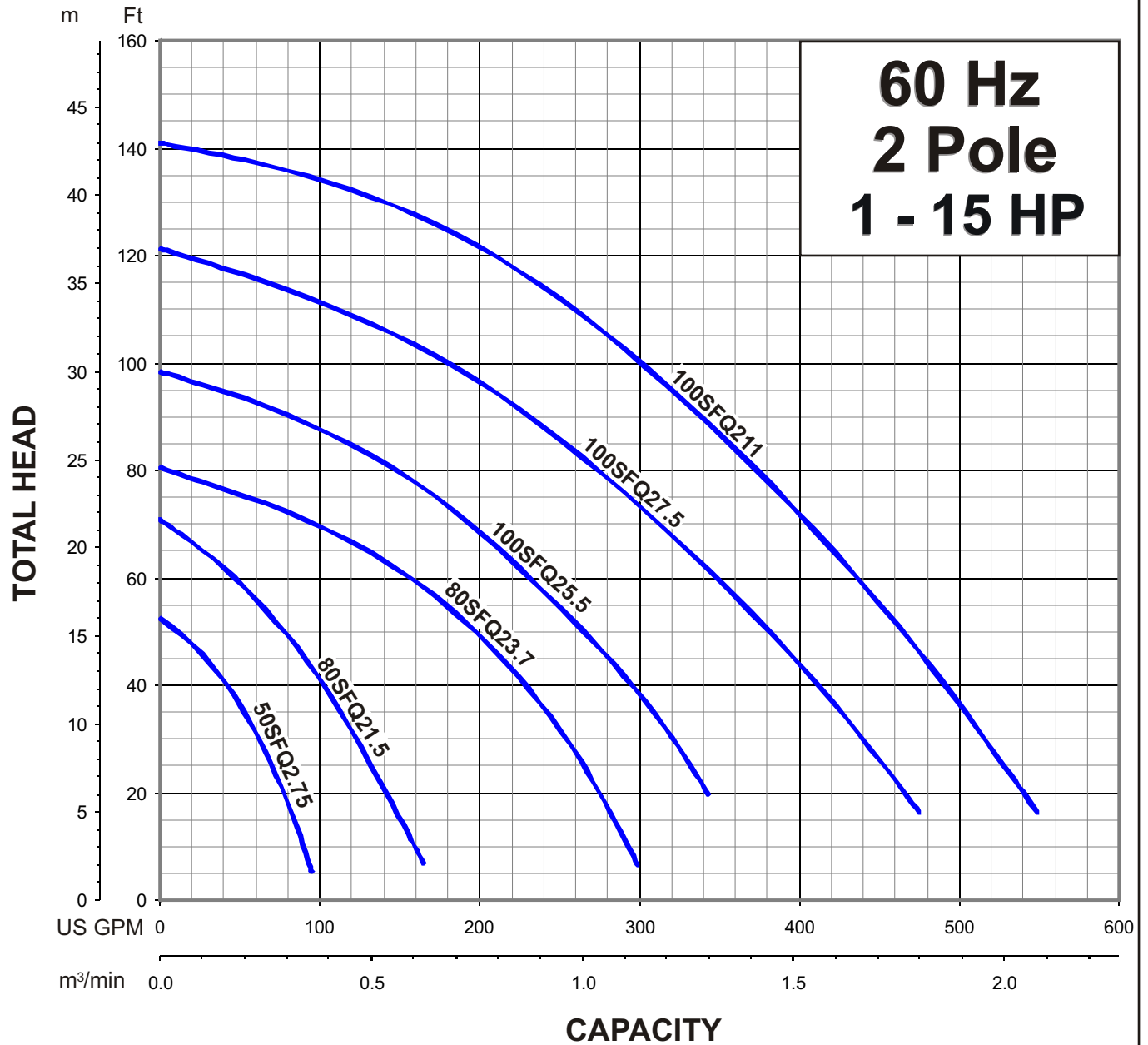



SFQ - SERIES

ALL 316 SS - DEWATERING PUMPS

PERFORMANCE CURVE

MODEL	BORE	HP	KW	RPM	SOLIDS DIA	LIQUID	SG.	VISCOSITY	TEMP.
80SFQ23.7-63	3"/80mm	5	3.7	3410	0.59"/15mm	Water	1.0	1.123 cSt.	60°F
PUMP TYPE	PHASE	VOLTAGE	AMPERAGE	HZ	STARTING METHOD	INS. CLASS			
All 316 SS - Dewatering Pump	3	208-230/460/575	13.8-12.8 / 6.4 / 5.0	60	Direct On Line	F			
CURVE No.	DATE	PHASE	VOLTAGE	AMPERAGE	HZ	STARTING METHOD	INS. CLASS		
-	-	-	-	-	-	-	-		

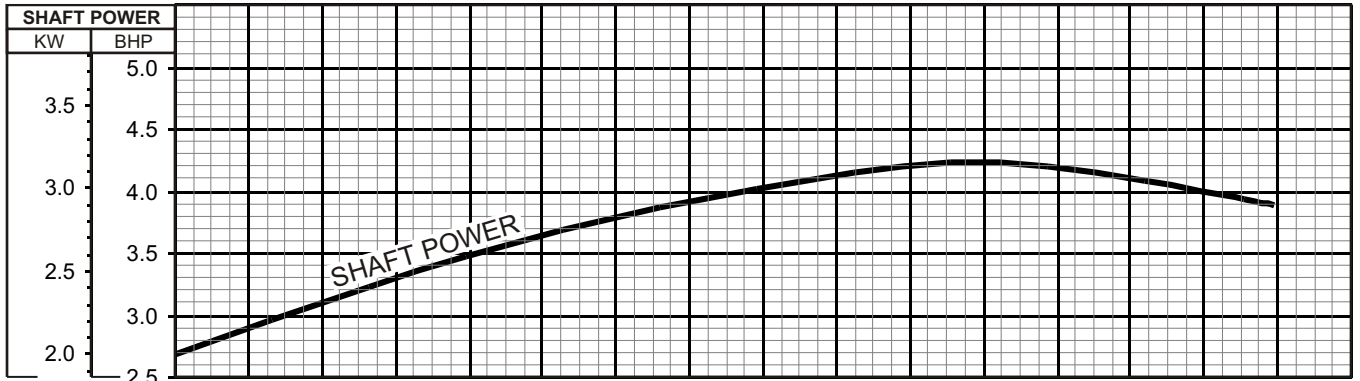
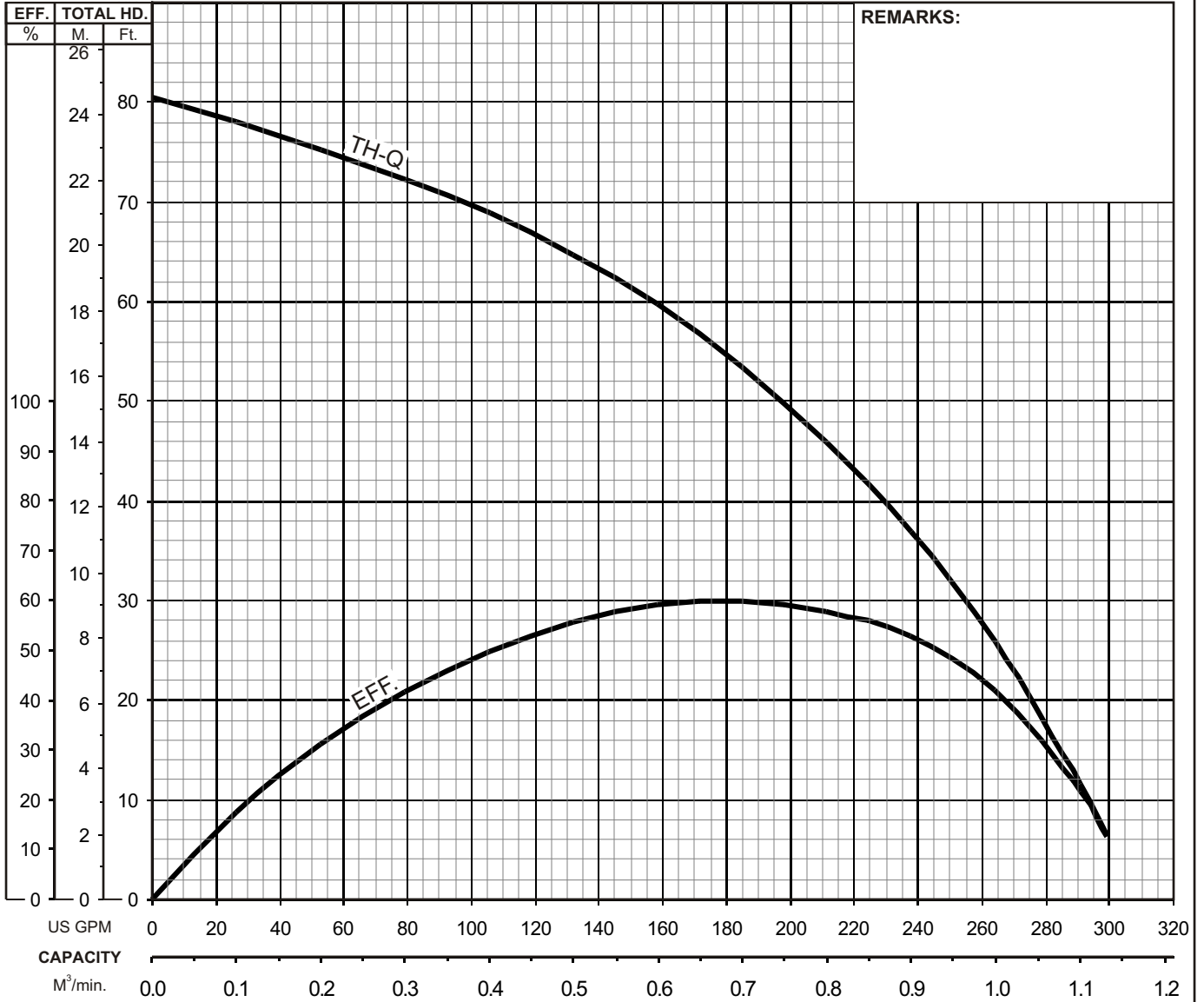



SFQ-SERIES
ALL316SS - DEWATERING PUMPS

DIMENSIONS

80SFQ23.7 -63

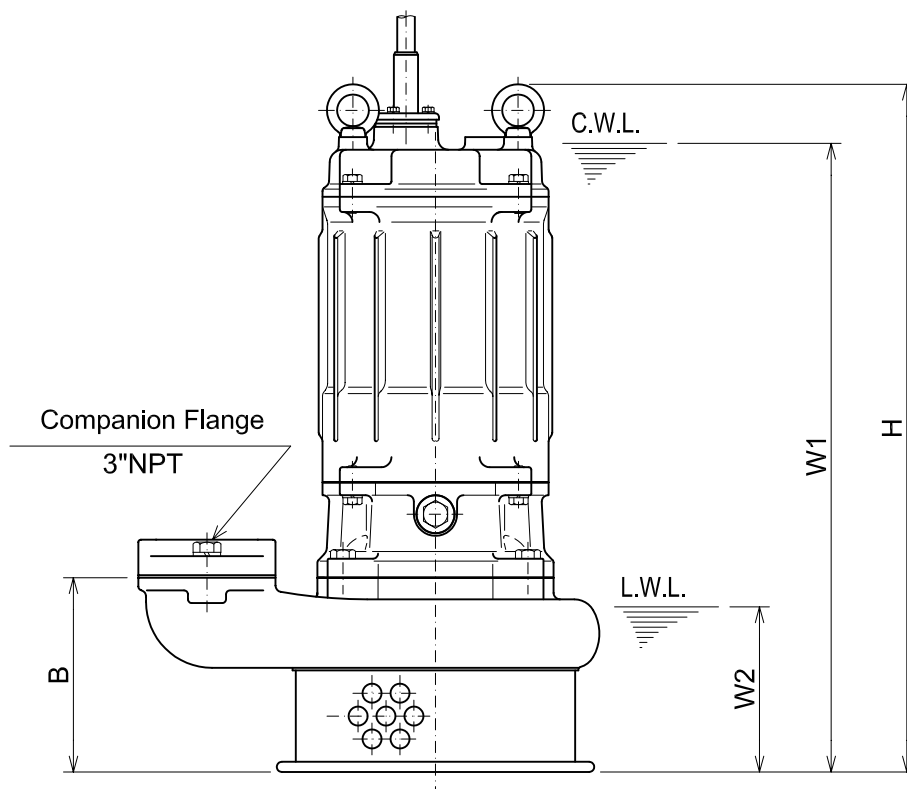
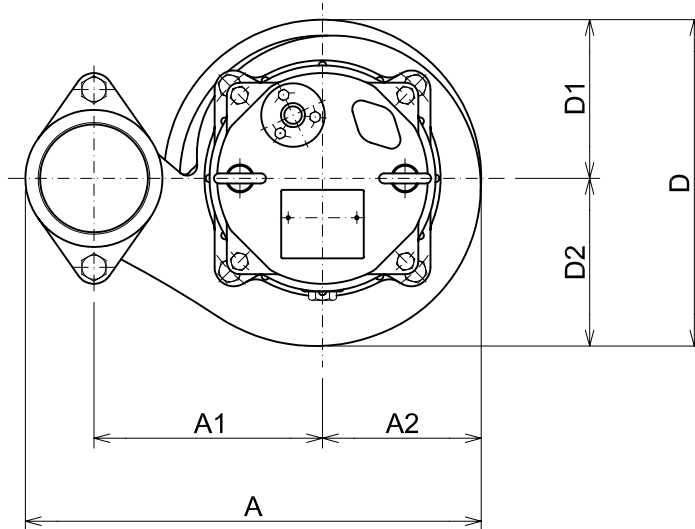

Companion Flange
3"NPT

C.W.L. :Continuous running Water Level
L.W.L. :Lowest running Water Level

DIMENSIONS:USCS(Inch)

Model	HP	NOM. SIZE	Pump & Motor							C.W.L.	L.W.L.	Wt. (lbs.)	
			A	A1	A2	B	D	D1	D2				H
80SFQ23.7 -63	5	3"	14 1/8	7 1/16	4 15/16	6	10 1/8	4 15/16	5 3/16	21 5/16	19 1/2	5 1/8	115

DIMENSIONS:METRIC(mm)

Model	kW	NOM. SIZE	Pump & Motor							C.W.L.	L.W.L.	Wt. (kg)	
			A	A1	A2	B	D	D1	D2				H
80SFQ23.7 -63	3.7	80	359	180	125	153	257	125	132	542	495	130	52

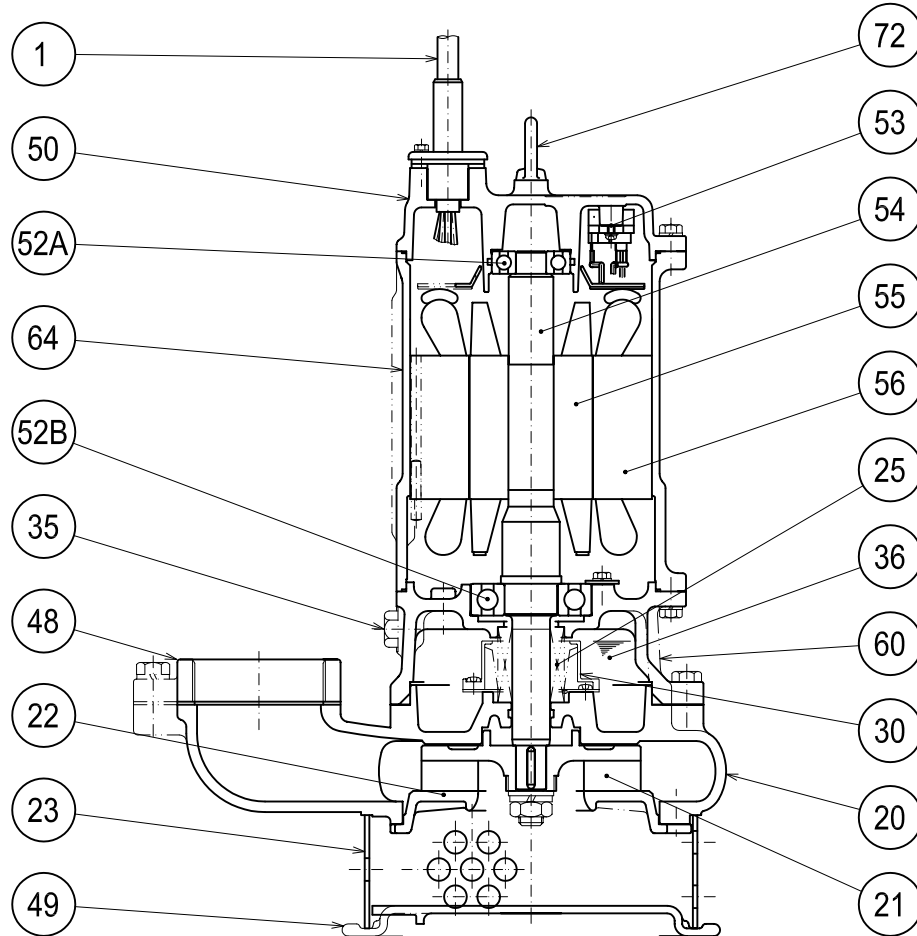
80SFQ23.7 -63

PART#	DESCRIPTION	MAIN MATERIAL / NOTE	RELATED ASTM,AISI CODE	RELATED EN CODE	QTY
1	Power Cable	PVC Sheath AWG 12/4-32ft			1
20	Pump Casing	Stainless Steel Casting	A743 CF-8M	GX5CrNiMo19-11-2	1
21	Impeller	Stainless Steel Casting	A743 CF-8M	GX5CrNiMo19-11-2	1
22	Suction Cover	Stainless Steel Casting	A743 CF-8M	GX5CrNiMo19-11-2	1
23	Suction Strainer	Stainless Steel	S 31600	1.4401	1
25	Mechanical Seal	Silicon Carbide / X-25W			1
30	Oil Lifter	PBT Resin W/GF40			1
35	Oil Plug	Stainless Steel	S 31600	1.4401	1
36	Lubricant	Turbine Oil ISO VG32 or SAE 10W-20			
48	Companion Flange	Stainless Steel Casting / NPT 3"	A743 CF-8M	GX5CrNiMo19-11-2	1
49	Bottom Plate	Stainless Steel Casting	A743 CF-8M	GX5CrNiMo19-11-2	1
50	Motor Bracket	Stainless Steel Casting	A743 CF-8M	GX5CrNiMo19-11-2	1
52A	Upper Bearing	#6304ZZC3			1
52B	Lower Bearing	#6307ZZC3			1
53	Motor Protector				1
54	Shaft	Stainless Steel	S 31600	1.4401	1
55	Rotor				1
56	Stator				1
60	Bearing Housing	Stainless Steel Casting	A743 CF-8M	GX5CrNiMo19-11-2	1
64	Motor Housing	Stainless Steel Casting	A743 CF-8M	GX5CrNiMo19-11-2	1
72	Lifting Lug Bolt	Stainless Steel	S 31600	1.4401	2

TSURUMI PUMP
SFQ - SERIES
ALL 316 SS- DEWATERING PUMPS
SAMPLE
SPECIFICATIONS
1. SCOPE OF SUPPLY -

Furnish and install TSURUMI Model _____ Submersible Pump(s). Each unit shall be capable of delivering _____ GPM (_____ m³/min) at _____ Feet (_____ m) TDH. The pump(s) shall be designed to pump waste water, without damage during operation. The pump(s) shall be designed so that the shaft power required (BHP)/(kW) shall not exceed the motor rated output throughout the entire operating range of the pump performance curve.

2. MATERIALS OF CONSTRUCTION -

All major parts of the pumping unit(s) including pump casing, impeller, discharge elbow, and motor frame shall be manufactured from 316 stainless steel. Unit(s) shall have a field adjustable/replaceable, 316 stainless steel wear plate. Impellers shall be of the multi-vane semi-open solids handling design, and shall be equipped with back pump out vanes, slip fit to the shaft and key driven. Internal and external surfaces coming into contact with the pumpage shall not require a protective coating. All exposed fasteners shall be stainless steel. All units shall be furnished with a discharge elbow with 150 lb. (10 kg/cm²) flat face flange and NPT companion flange.

3. MECHANICAL SEAL -

All units shall be furnished with a dual inside mechanical shaft seal located completely out of the pumpage, running in a separate oil filled chamber and further protected by an exclusionary oil seal located between the bottom seal faces and the fluid being pumped. The oil chamber by virtue of design shall prevent vortexing of the oil therein, units 1 Hp and above shall be fitted with a device that shall provide positive lubrication of the top mechanical seal, (down to one third of the standard oil level). The device shall not consume any additional electrical power. Mechanical seals shall be rated to preclude the incursion of water up to 42.6 PSI. (98.4 Ft.) submergence. Units shall have silicon carbide versus silicon carbide upper and lower mechanical seal faces. Mechanical seal hardware shall be stainless steel. Units 7.5 Hp and above shall incorporate seal pressure relief ports. Mechanical seals elastomers shall be viton.

4. MOTOR-

The pump motor(s) shall be _____ Hp., _____ kW., _____ V., 60 Hz. Phase and shall be NEMA MG-1, Design Type B equivalent. Motor(s) shall be rated at _____ full load amps. Motor(s) shall have a 1.15 service factor and shall be rated for 20 starts per hour. Motor(s) shall be air filled, copper wound, class F or E (up to 5 Hp) insulated with built in thermal and over amperage protection for each winding. Motor shaft shall be 316 stainless steel and shall be supported by two permanently lubricated, high temperature ball bearings, with a B-10 life rating at best efficiency point of 60,000 hours. The bottom bearings on units up to 5 Hp shall be single row, double shielded, C3, deep groove type ball bearing. Units 7.5 Hp and above shall have two row, double shielded, C3, deep groove type ball bearing. The top bearings on all units shall be single row, double shielded, C3, deep groove type ball bearing. Motors shall be D.O.L. or star-delta start (15 Hp), and shall be suitable for across the line start or variable speed applications, utilizing a properly sized variable frequency drive.

5. POWER CABLE AND CABLE ENTRANCE -

Units up to 5 Hp shall be supplied with a cable entrance that incorporates built in strain relief, a one piece, three way mechanical compression seal and a fatigue reducing cable boot. The pump power cable shall be suitable for submersible pump applications. The power cable on units 7.5 Hp and above shall be field replaceable utilizing standard submersible pump cable. The cable entrance shall incorporate built in strain relief and a combination three way mechanical compression sealing. The cable entrance assembly shall contain an anti-wicking block to eliminate water incursion into the motor due to capillary wicking should the power cable be accidentally damaged.