

TYPICAL WIRING DIAGRAM: STAR-DELTA START MOTORS <3>

The below diagrams show typical wiring connections for D.O.L. (across the line starting) of Tsurumi Pumps supplied with Star Delta Start motors.

Diagram C applies to series: B pumps with 40 - 200 HP (30 - 150 kW) motors. The motors are supplied with (2) Power cables. Power cable #1 contains: (1) red conductor “U”, (1) white conductor “V”, and (1) black conductor “W”. Power cable #2 contains: (1) green conductor “G” (ground), (2) Yellow Thermal Protector conductors “P1& P2”, (1) White Seal Sensor conductor “M”, (1) red conductor “Z”, (1) white conductor “X” and (1) black conductor “Y”. In order to connect the unit for D.O.L start, the conductors in Power cable #1 and Power cable #2 must be connected together at the motor contactor output terminals (shown below as 1T1, 1T2 & 1T3) in the following manner: “U” & “Z” connected to 1T1, “V” & “X” connected to 1T2, “W” & ”V” connected to 1T3, and “G” connected to ground.

**STAR DELTA MOTOR CONNECTED FOR D.O.L. START
SERIES B, 40 - 200 HP (22 - 150 kW) • ALL RPM**

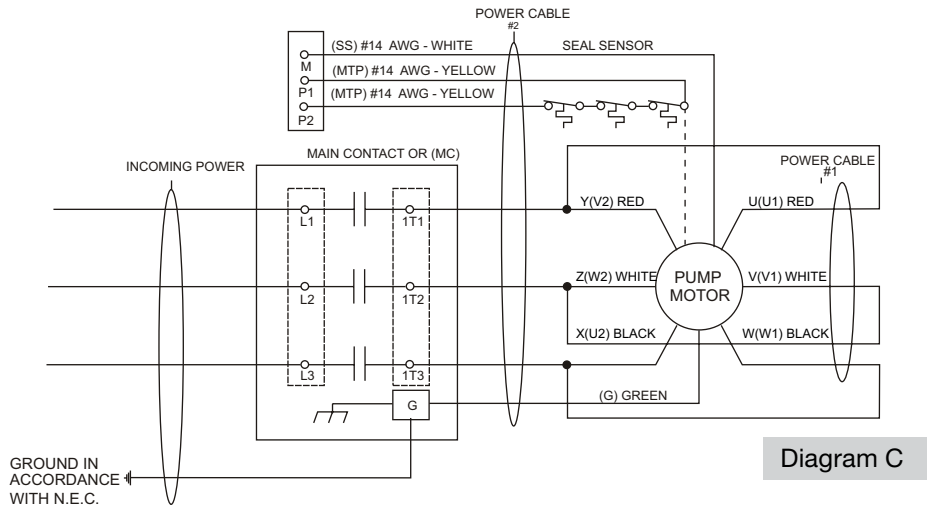

Diagram C

Diagram D applies to series: B & C pumps with 15 - 20 HP (11 - 15 kW) • 6P (1200 RPM) motors. The motors are supplied with (1) Power cable, and supplied as an option, (1) Seal Sensor cable. The power cable contains: (2) Yellow Thermal Protector conductors “P1 & P2”, (1) green conductor “G” (ground), (1) red conductor “U1”, (1) white conductor “V1”, (1) black conductor “W1”, (1) red conductor “V2”, (1) white conductor “W2” and (1) black conductor “U2”. In order to connect the unit for D.O.L start, the conductors must be connected together at the motor contactor output terminals,(shown below as 1T1, 1T2 & 1T3) in the following manner: “U1” & “V2” connected to 1T1, “V1” & “W2” connected to 1T2, “W1” & ”U2” connected to 1T3, and “G” connected to ground.

**STAR DELTA MOTOR CONNECTED FOR D.O.L. START
SERIES B & C, 15- 20 HP (11 - 15 kW) • 6P (1200 RPM)**

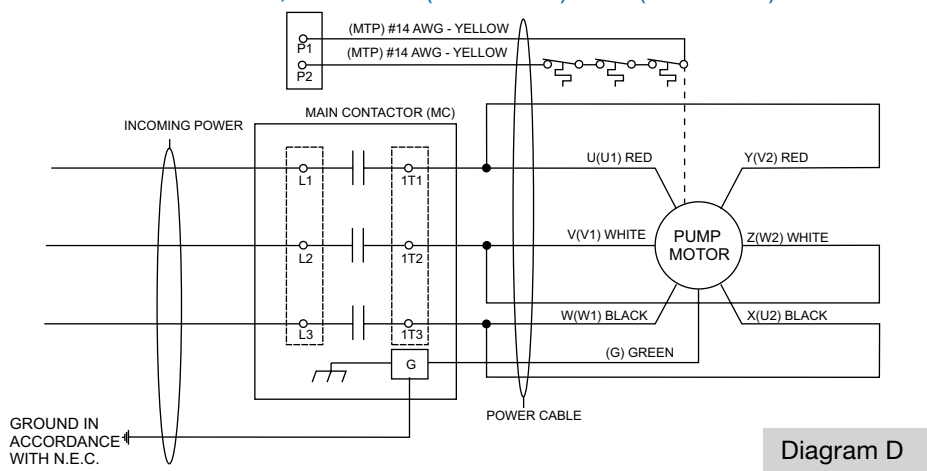

Diagram D