

PARTS LIST		SEWAGE AND WASTEWATER PUMP			1/9/2024	
ITEM	PART No.	DESCRIPTION	QTY	SIZE	MATERIAL	NOTES
1	001-938-25	Cabtyre Cable Set (32') 60Hz (USA)	1	2PNCT4Cx5.5mm2	KR-2	
2	140-035-14	Hex.Bolt	2	M6x20	SUS304	included in ITEM#1 Cable Ass'y
3	070-107-18	Cable Clamp	1		FC150	included in ITEM#1 Cable Ass'y
4	140-056-11	Hex.Bolt	4	M8x30	SUS304	
5	142-163-18	Spring Washer	4	M8	SUS304	
6	006-126-14	Stuffing Box	1	No.2	FC200	included in ITEM#1 Cable Ass'y
7	008-143-13	Mould Cover	1	KR2-8	CR	included in ITEM#1 Cable Ass'y
8	143-085-21	Pan Screw (w/Spring Washer)	1	M4x6	SWRM	
9	009-130-10	Terminal	1	R-5.5-4	CU	included in ITEM#1 Cable Ass'y
10	009-276-19	Compression type Terminal	3	TMNB-5.5(Insulated)		included in ITEM#1 Cable Ass'y
11	072-107-27	Eye Bolt	2	M16	SUS304	
12	142-399-15	Washer		d17xd29x0.1t	SUS304	
	142-400-10	Washer		d17xd29x0.3t	SUS304	
13	140-098-15	Hex.Bolt	4	M12x35	SUS304	
14	142-165-10	Spring Washer	4	M12	SUS304	
15	050-001-21	Motor Bracket	1		FC200	
16	122-173-19	O-Ring	1	V-225(222.5xd6)	NBR	*
17	142-198-12	Wave Washer	1	6306	SK5	
18	052-000-25	Bearing (w/O-ring)	1	AC-6306ZZC3		
19	143-126-25	Pan Screw (w/Spring Washer/Plain Washer)	2	M4x12	SWRM	
20	053-000-05	Motor Protector 208/230V-60Hz(USA)	1	KA314-HLBL00	(B.C)	
20	053-192-17	Motor Protector 460V-60Hz(USA)	1	KA314-HKXL00	(B.C)	
20	053-192-17	Motor Protector 575V-60Hz(USA)	1	KA314-HKXL00	(B.C)	
21	058-000-09	Lead Wire Protection Plate	1	d86xd224x1.6t	SPHC	
22	055-000-08	Rotor	1Set			
23	147-163-13	Impeller Key	1	10x8x32L	SUS420	
24	056-010-36	Stator 208/230V-60Hz(USA)	1Set			
24	056-010-37	Stator 460V-60Hz(USA)	1Set			
24	056-010-38	Stator 575V-60Hz(USA)	1Set			
	181-000-03	Cable Tie	2	T50S,158Lx4.7Bx35D	Nylon	
25	002-000-83	Protection Tube	m	NFG-1A,d7	(V/m)	
26	009-000-31	Terminal	3	R-5.5-S4	CU	
27	140-100-11	Hex.Bolt	4	M12x45	SUS304	
28	142-165-10	Spring Washer	4	M12	SUS304	
29	064-000-71	Motor Frame	1		FC200	
30	122-173-19	O-Ring	1	V-225(222.5xd6)	NBR	*
31	140-000-06	Hex.Bolt (w/Spring Washer/Plain Washer)	3	M6x12	SWCH	

PARTS LIST		SEWAGE AND WASTEWATER PUMP			1/9/2024	
ITEM	PART No.	DESCRIPTION	QTY	SIZE	MATERIAL	NOTES
32	052-001-08	Bearing	1	6309ZC3(SRL)		
33	140-099-16	Hex.Bolt	2	M12x40	SUS304	
34	142-165-10	Spring Washer	2	M12	SUS304	
35	140-104-15	Hex.Bolt	4	M12x65	SUS304	
36	142-165-10	Spring Washer	4	M12	SUS304	
37	121-247-12	Packing	2	d12.3xd18x2t	Polyethylene	*
38	035-113-18	Oil Plug	2	M12x14	SUS304	
39	060-002-31	Bearing Housing	1		FC200	
40	122-159-19	O-Ring	1	G-280(279.3xd5.7)	NBR	*
41	025-195-39	Mechanical Seal	1	H-35	SIC	
42	143-070-23	Pan Screw	2	M5x6	SWRM	
43	030-156-18	Oil Lifter	1	H-35(A)(T)	Resin	
44	143-070-10	Pan Screw	3	M5x6	SWRM	
45	030-150-12	Seal Stopper	1	H-35(A)(T)	SPCC	
46	029-187-14	Oil Casing	1	100-5.5/7.5-4B2	FC200	
47	122-159-19	O-Ring	1	G-280(279.3xd5.7)	NBR	*
48	026-115-12	Oil Seal	1	TC-608212	NBR	
49	021-B55-19	Impeller (60Hz)	1	150B47.5L-66	FC	
50	142-202-10	Impeller Fixing Washer	1	d13xd50x15t	SUS304	
51	144-530-16	Hex.Socket Set Screw	2	M6x15	SUS304	
52	142-000-22	Spring Washer	1	M12(CP)	SUS304	
53	140-304-17	Hex.Socket Cap Bolt	1	M12x45	SUS304	
54	046-107-13	Air Release Valve	1	PT-1/2	Nylon	
55	020-689-14	Pump Casing	1	200-11-4B3	FC	
56	120-173-13	Packing (S.Cover)		d321xd348x0.5t	Polyethylene	
57	022-536-11	Suction Cover	1	200-11-4B2	FC	
58	142-165-10	Spring Washer	3	M12	SUS304	
59	140-097-14	Hex.Bolt	3	M12x30	SUS304	
63-1	142-165-10	Spring Washer	3	M12	SUS304	
64-1	140-100-11	Hex.Bolt	3	M12x45	SUS304	
60	023-289-19	Pump Stand	3	200-11-4B2	FCD	included in STAND SET 6C
61	142-165-10	Spring Washer	3	M12	SUS304	included in STAND SET 6C
62	140-097-14	Hex.Bolt	3	M12x30	SUS304	included in STAND SET 6C
63	142-165-10	Spring Washer	3	M12	SUS304	included in STAND SET 6C
64	140-103-14	Hex.Bolt	3	M12x60	SUS304	included in STAND SET 6C
65	037-119-10	Discharge Bend	1	150x150mm	FC	included in BEND 6-6 NPT
66	121-165-28	Packing	1	JIS5Kx150mm	NR	included in BEND 6-6 NPT

PARTS LIST		SEWAGE AND WASTEWATER PUMP			1/9/2024	
ITEM	PART No.	DESCRIPTION	QTY	SIZE	MATERIAL	NOTES
67	142-166-11	Spring Washer	8	M16	SUS304	included in BEND 6-6 NPT
68	140-127-14	Hex.Bolt	8	M16x55	SUS304	included in BEND 6-6 NPT
69-83	SEE PARTS LIST FOR TOS-150					
	173-001-16	Packing O-Ring Set	1Set	(Marked by *)		
16	122-173-19	O-Ring (M.Bracket/M.Frame)	1	V-225(222.5xd6)	NBR	*
30	122-173-19	O-Ring (M.Frame/Brg.Housing)	1	V-225(222.5xd6)	NBR	*
37	121-247-12	Packing (Oil Plug)	2	d12.3xd18x2t	Polyethylene	*
40	122-159-19	O-Ring (Brg.Housing/O.Casing)	1	G-280(279.3xd5.7)	NBR	*
47	122-159-19	O-Ring (O.Casing/P.Casing)	1	G-280(279.3xd5.7)	NBR	*
		Lubricant		Turbine Oil VG32 4,800ml		

* Indicates items included in set

PARTS LIST		SEWAGE AND WASTEWATER PUMP				1/9/2024
ITEM	PART No.	DESCRIPTION	QTY	SIZE	MATERIAL	NOTES

150B47. 5L-66

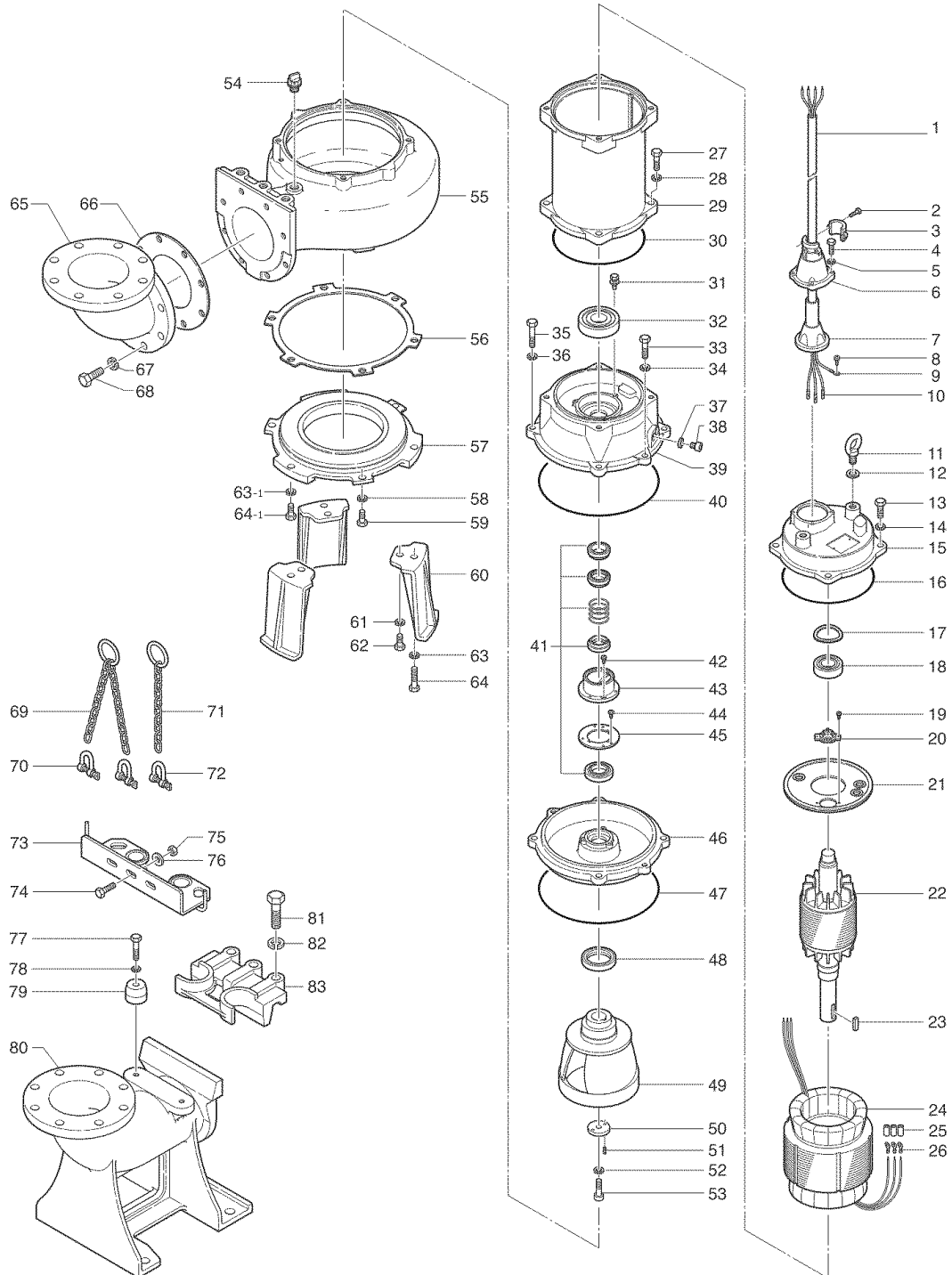

C-01570-1

* Indicates items included in set