



**KTZ-SERIES
DEWATERING PUMP**

SPECIFICATIONS

■ FEATURES

1. Semi-open, high chrome iron impeller with ductile iron wear plate increases wear resistance when pumpage contains abrasive particles.
2. Double inside mechanical seals with silicon carbide faces, running in an oil filled chamber and further protected by a lip seal running against a replaceable, 430 stainless steel shaft sleeve, provides for the most durable seal design available.
3. Highly efficient, continuous duty air filled, copper wound motor with class F insulation minimizes the cost of operation.
4. Built in thermal & amperage sensing protector prevents motor failure due to single Phasing,

overloading or accidental run -dry conditions.

5. Double shielded, permanently lubricated, high temperature C3 ball bearings, rated for a B-10 life of 60,000 hours, extend operational life.
6. Top discharge, flow-thru design enables operation at low water levels for extended periods.

■ APPLICATIONS

1. Commercial, industrial wastewater and construction site drainage.
2. Effluent transfer.
3. Decorative waterfalls and fountains.
4. Raw water supply from rivers or lakes..



■ SPECIFICATIONS

Discharge Size
 Horsepower Range
 Performance Range Capacity Head
 Maximum water temperature
 Materials of Construction
 Casing
 Impeller
 Shaft
 Motor Frame
 Fasteners
 Seal Pressure Relief Ports
 Mechanical Seal
 Elastomers
 Impeller Type
 Solids Handling Capability
 Motor Nomenclature
 Type, Speed, Hz.
 Voltage, Phase
 Insulation
 Bearings
 Accessories
 Operational Mode

■ STANDARD

2 ~ 4" NPT (50 - 100 mm)
 6" is Optional (KTZ67.5 / KTZ611)
 2 ~ 15 HP. (1.5 ~ 11 Kw)
 33.0 ~ 645.0 GPM. (0.13 ~ 2.44 m³/min)
 13.1 ~ 167.0 Ft. (4.0 ~ 50.9 m)
 104° F. (40° C.)
 Cast Iron
 High Chrome Iron
 420 Stainless Steel
 Cast Iron
 304 Stainless Steel
 10 - 15HP (7.5 - 11kW)
 Silicon Carbide
 NBR (Nitrile Butadiene Rubber)
 Semi-open, solids handling.
 0.334 - 0.787" (8.5 - 20.0mm)
 Air Filled, 3600 RPM, 60 Hz.
 208/230/460/575 V., 3 Phase
 Class F
 Pre-lubricated, Double Shielded
 Submersible Power Cable 50' (15.0m)
 Manual

■ OPTIONS

Length as Required



TSURUMI PUMP

Positive Effect of Advanced KTZ KTZE – Automatic Pump with **Electrode**

1.5 / 2.2 / 3.7kW

Automatic Operation with Electrode

The electrode-type sensor ON/OFF operation prevents dry running, reduces power consumption (50% over standard type – Tsurumi comparison), and extends operational life.

Energy Conservation

Cost Saving

Noise Reduction

Multi-Directional Hose Coupling

The hose coupling has been devised so that it can be, without any extra parts, converted to an inclined discharge direction.



Every KTZ-series pump (1.5 to 11kW) is equipped with the above hose coupling as standard.

* The additional features do NOT affect on the pump performance.



TSURUMI PUMP

**KTZ(E) - SERIES
DEWATERING PUMPS**

**PERFORMANCE
RANGE**

GROUP PERFORMANCE RANGE

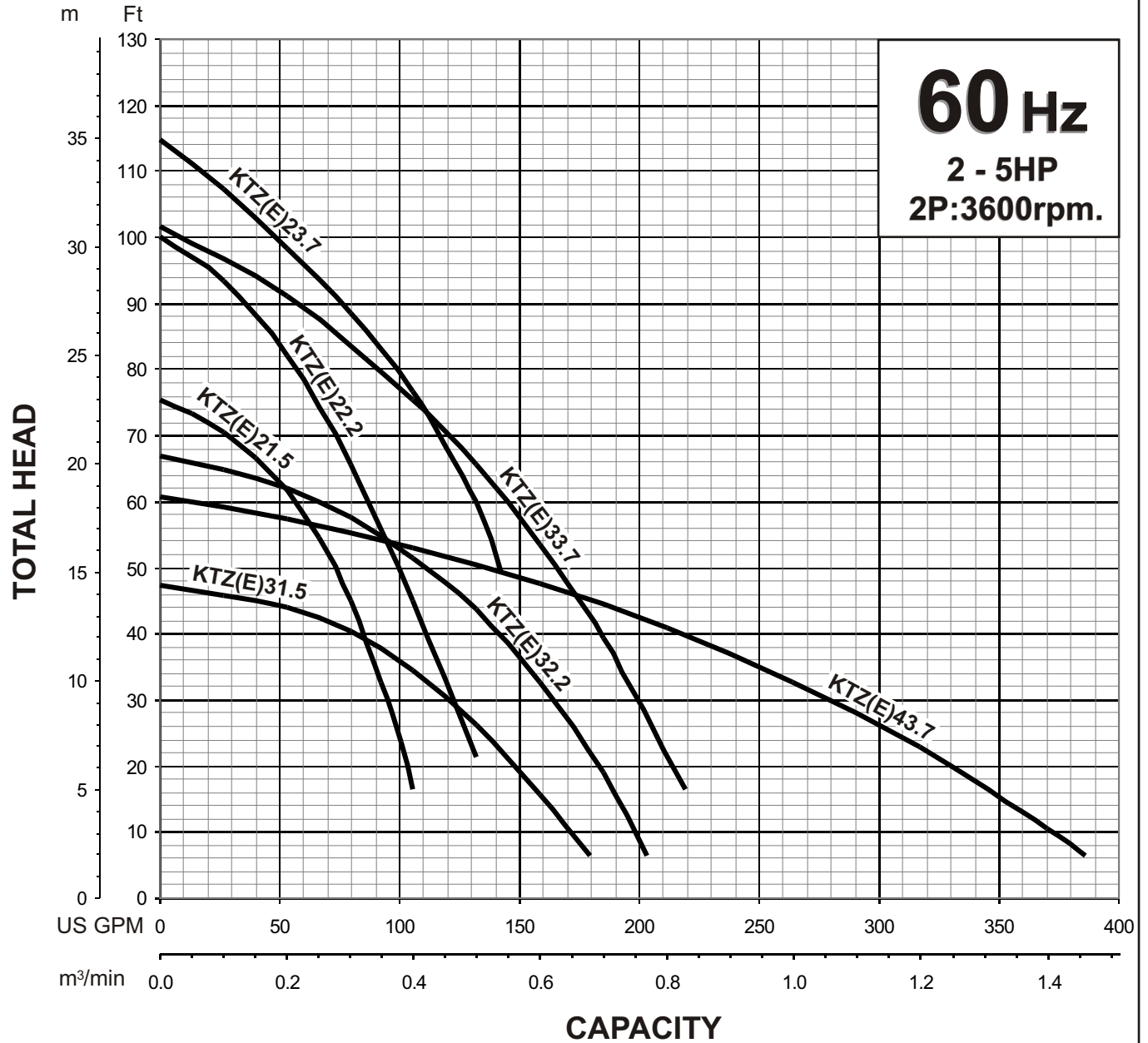



KTZ - SERIES DEWATERING PUMPS

PERFORMANCE CURVE

MODEL	BORE	HP	KW	RPM	SOLIDS DIA	LIQUID	SG.	VISCOSITY	TEMP.
KTZ32.2-61	3"/80mm	3	2.2	3410	0.334"/8.5mm	Water	1.0	1.123 cSt.	60°F
PUMP TYPE	PHASE	VOLTAGE	AMPERAGE	HZ	STARTING METHOD	INS. CLASS			
Dewatering Pump	3	208-230/460/575	9.4-9.0 / 4.5 / 3.5	60	Direct On Line	F			
CURVE No.	DATE	PHASE	VOLTAGE	AMPERAGE	HZ	STARTING METHOD	INS. CLASS		
-	-	-	-	-	-	-	-		

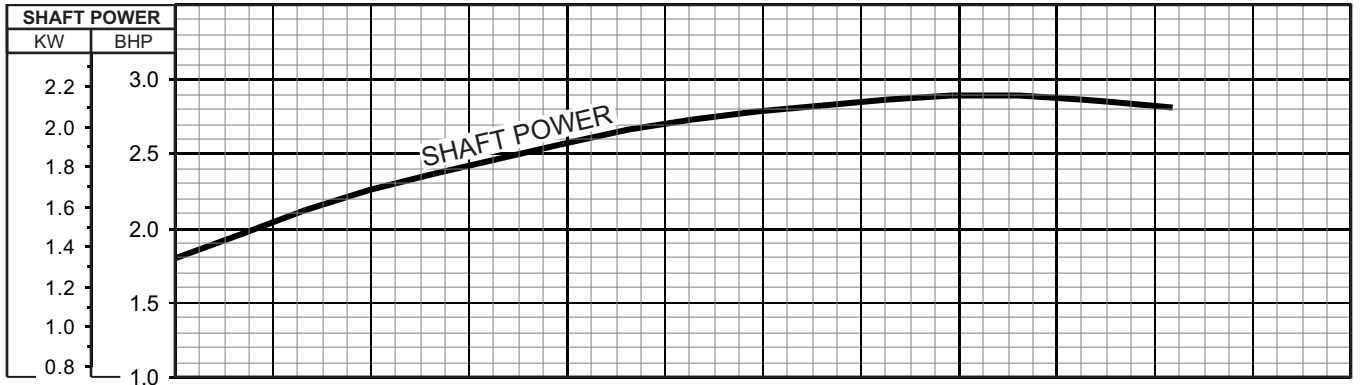
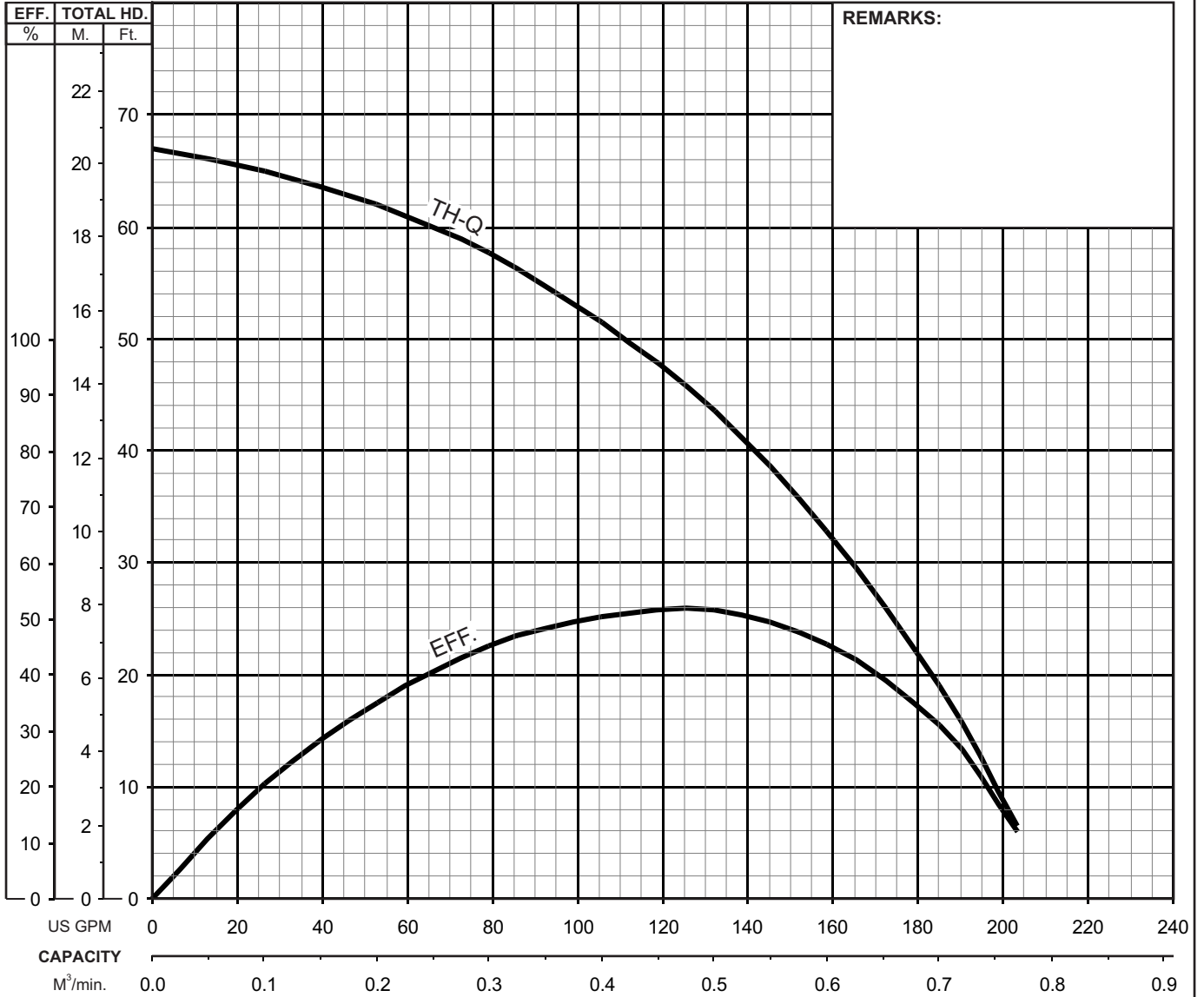



**KTZ - SERIES
DEWATERING PUMPS**

DIMENSIONS

**KTZ22.2-61
KTZ32.2-61**

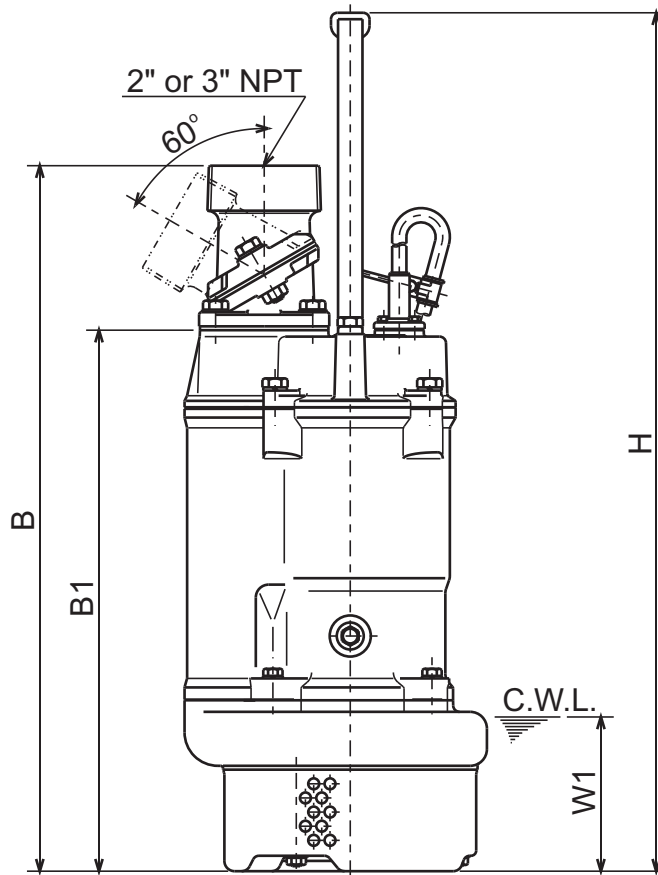
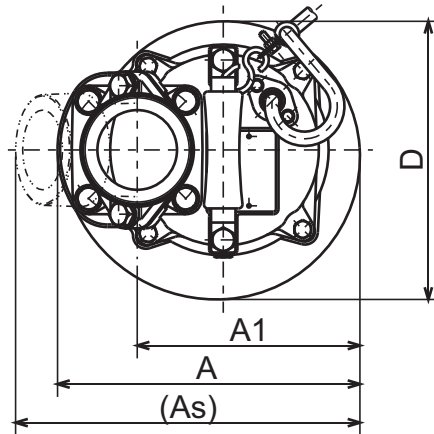

C.W.L. : Continuous running Water Level

DIMENSIONS:USCS (Inch)

Model	HP	NOM. SIZE	Pump & Motor							C.W.L. W1	Wt. (lbs.)
			A	As	A1	B	B1	D	H		
KTZ22.2-61	3	2"	9 1/4	10 1/4	6 13/16	21 5/8	16 9/16	8 1/2	26 5/16	4 3/4	79
KTZ32.2-61	3	3"	9 1/4	10 9/16	6 13/16	21 5/8	16 9/16	8 1/2	26 5/16	4 3/4	77

DIMENSIONS:METRIC (mm)

Model	kW	NOM. SIZE	Pump & Motor							C.W.L. W1	Wt. (kg)
			A	As	A1	B	B1	D	H		
KTZ22.2-61	2.2	50	235	261	173	549	421	216	668	120	36
KTZ32.2-61	2.2	80	235	268	173	549	421	216	668	120	35

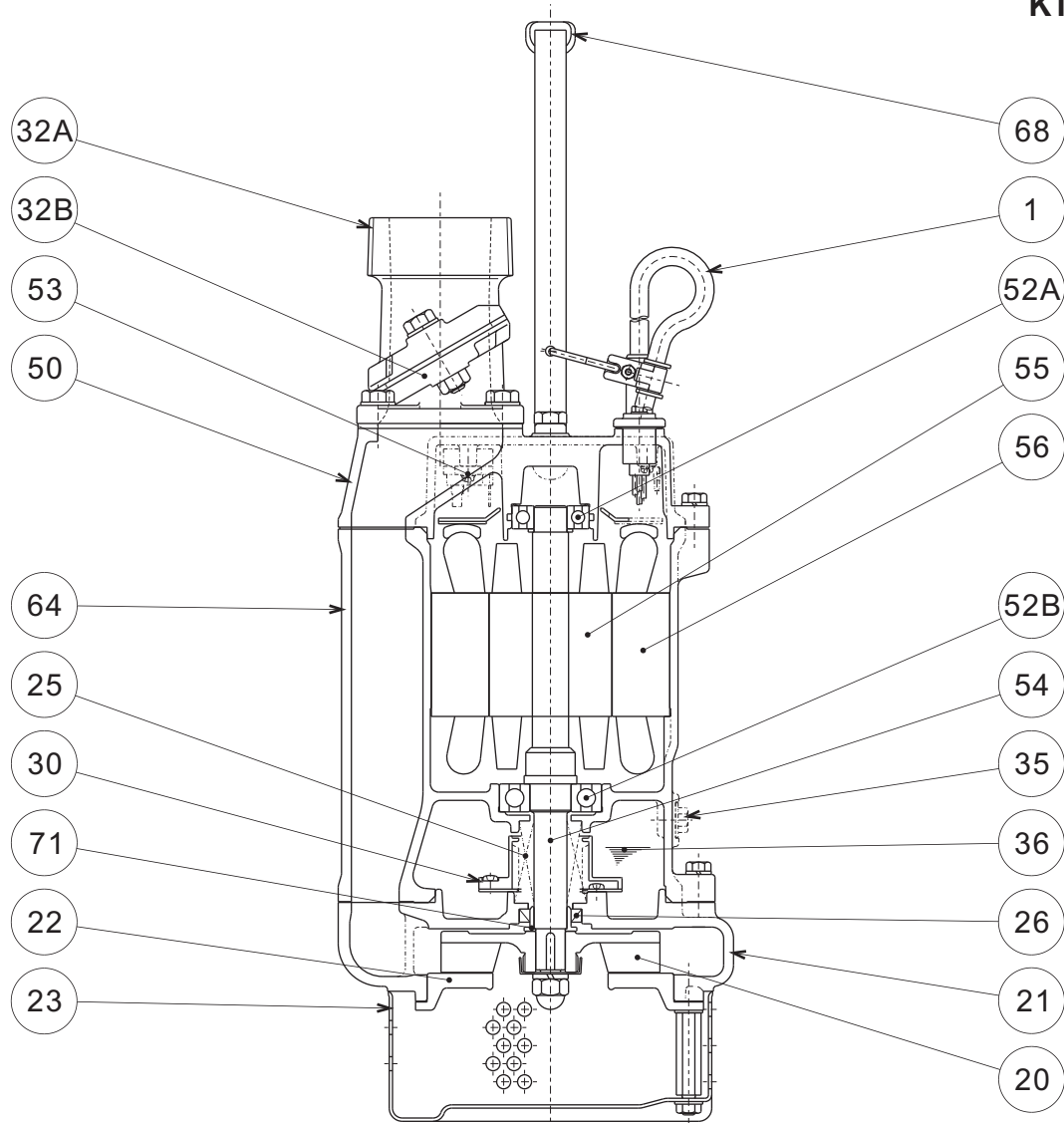
**KTZ22.2-61
KTZ32.2-61**

ITEM#	DESCRIPTION	MAIN MATERIAL / NOTE	RELATED ASTM, AISI CODE	RELATED EN CODE	Q'TY
1	Power Cable	PVC Sheath AWG16/4-50ft			1
20	Pump Casing	Cast Iron	A48M Class30B	EN 1561 GJL-200	1
21	Impeller	High Chrome Cast Iron	A532 Class III Type A	DIN 1695 G-X260Cr27	1
22	Suction Cover	Ductile Cast Iron	A536 80-55-06	EN 1563 GJS-500-7	1
23	Suction Strainer	Steel (Cold Rolled)	A109/A1008	EN 10130	1
25	Mechanical Seal	Silicon Carbide / H-20T			1
26	Oil Seal	Nitrile Butadiene Rubber / TC-25388			1
30	Oil Lifter	PBT Resin			1
32A	Discharge Connection	Cast Iron / NPT 2" or 3"	A48M Class30B	EN 1561 GJL-200	1
32B	Attachment	Aluminum Alloy Die Casting	B85 383.0	EN 1706 AC-46100	1
35	Oil Plug	Stainless Steel	S 30400	1.4301	1
36	Lubricant	Turbine Oil ISO VG32 or SAE10W-20			
50	Motor Head Cover	Cast Iron	A48M Class25B	EN 1561 GJL-150	1
52A	Upper Bearing	#6204ZZC3			1
52B	Lower Bearing	#6305ZZC3			1
53	Motor Protector				1
54	Shaft	Stainless Steel	S 42000	1.4028	1
55	Rotor				1
56	Stator				1
64	Motor Housing	Cast Iron	A48M Class25B	EN 1561 GJL-150	1
68	Handle	Steel (Cold Rolled) + NBR Rubber	A109/A1008	EN 10130	1
71	Shaft Sleeve	Stainless Steel	S 30400	1.4301	1

TSURUMI PUMP
**KTZ - SERIES
DEWATERING PUMPS**
**SAMPLE
SPECIFICATIONS**

1. SCOPE OF SUPPLY -

Furnish and install TSURUMI Model _____ Submersible Pump(s).
Each unit shall be capable of delivering _____ GPM (_____ m³/min) at _____ Feet (_____ m) TDH. The pump(s) shall be designed to pump waste water, without damage during operation. The pump(s) shall be designed so that the shaft power required (BHP)/(kW) shall not exceed the motor rated output throughout the entire operating range of the pump performance curve. Pump(s) shall be of the top discharge, flow through design.

2. MATERIALS OF CONSTRUCTION -

Construction of major parts of the pumping unit(s) shall be as follows: Pump casing shall be gray cast iron, ASTM A48 CLASS 35. Motor frame shall be gray cast iron, ASTM A48 CLASS 30. Field adjustable/replaceable, wear plate shall be ductile cast iron. Impellers shall be of the multi-vane semi-open design and shall be high chrome cast iron. Impellers shall be equipped with back pump out vanes, slip fit to the shaft and key driven. Internal and external surfaces coming into contact with the pumpage shall be protected by a fused polymer coating. All exposed fasteners shall be stainless steel. All units shall be furnished with _____" NPT discharge connector.

3. MECHANICAL SEAL -

All units shall be furnished with a dual inside mechanical shaft seal located completely out of the pumpage, running in a separate oil filled chamber and further protected by an exclusionary oil seal located between the bottom seal faces and the fluid being pumped. The oil chamber shall be fitted with a device that shall provide positive lubrication of the top mechanical seal, (down to one third of the standard oil level). The device shall not consume any additional electrical power. Mechanical seals shall be rated to preclude the incursion of water up to 42.6 PSI (98.4 Ft.) submergence. Units shall have silicon carbide mechanical seal faces. Mechanical seal hardware shall be stainless steel.

4. MOTOR-

The pump motor(s) shall be _____ H P., _____ kW., _____ V., 60 Hz. 3 Phase and shall be NEMA MG-1, Design Type B equivalent. Motor(s) shall be rated at _____ full load amps. Motor(s) shall have a 1.15 service factor and shall be rated for 20 starts per hour. Motor(s) shall be air filled, copper wound, class B or E (up to 7.5 Hp) insulated with built in thermal and over amperage protection for each winding. Motor shaft shall be 420 stainless steel, fitted with a replaceable 403 stainless steel shaft sleeve and shall be supported by two permanently lubricated, high temperature ball bearings, with a B-10 life rating at best efficiency point of 60,000 hours. Bearings on all units shall be single row, double shielded, C3, deep groove type ball bearing. Motors shall be suitable for across the line start or variable speed applications, utilizing a properly sized variable frequency drive.

5. POWER CABLE AND CABLE ENTRANCE -

Units up to 3 HP shall be supplied with a cable entrance that incorporates built in strain relief, a one piece, three way mechanical compression seal and a fatigue reducing cable boot. The pump power cable shall be suitable for submersible pump applications. The power cable on units 5 Hp and above shall be field replaceable utilizing standard submersible pump cable. The cable entrance shall incorporate built in strain relief and a combination three way mechanical compression sealing with a fatigue reducing boot. The cable entrance assembly shall contain an anti-wicking block to eliminate water incursion into the motor due to capillary wicking should the power cable be accidentally damaged.