

PARTS LIST		CONTRACTOR PUMPS				8/5/2019
ITEM	PART No.	DESCRIPTION	QTY	SIZE	MATERIAL	NOTES
1	009-113-17	Terminal	3	R-38-10	CU	
2	009-107-18	Terminal	1	R-14-6	CU	
3	009-116-10	Terminal	3	R-2-4	CU	
4	010-103-21	Cable Clip	2	No.4	SPC	
5	140-074-15	Hex.Bolt	3	M10x20	SUS304	
6	141-006-19	Hex.Nut	3	M10	SUS304	
7	001-140-19	Cabtyre Cable (per meter) 60Hz(USA)	15	2PNCTFMulti-core7Cx38mm2	(Vm)	
8	010-129-10	Cable Clip Rubber	1	115x100x2t	NBR	
9	140-058-42	Hex.Bolt	4	M8x40	SUS304	
10	141-005-18	Hex.Nut	4	M8	SUS304	
11	003-106-19	Gland	1	No.5	FC	
12	004-113-12	Cable Bush	1	No.12	SBR	
13	140-076-17	Hex.Bolt	4	M10x30	SUS304	
14	142-164-19	Spring Washer	4	M10	SUS304	
15	006-000-08	Stuffing Box	1	GSZ3-22-6	FC	
16	122-132-16	O-Ring	1	G-105(104.4xd3.1)	NBR	*
17	009-168-17	Terminal	1	R-22-S6	CU	
18	140-029-28	Hex.Bolt	1	M6x10	SWRM	
19	009-114-18	Connector	2	PC-4020M		
20	009-114-18	Connector	1	PC-4020M		
21	009-115-19	Connector	1	PC-4020F		
22	009-115-19	Connector	2	PC-4020F		
23	141-004-59	Hex.Nut	4	M6	SWRM	
24	009-108-19	Terminal	3	R-38-6	CU	
25	009-106-17	Terminal	6	R-8-6	CU	
26	140-030-35	Hex.Bolt	3	M6x12	SWRM	
27	002-128-14	Heat Shrink Tube (Sold per meter)	m	EVA(d10x1t)	(Vm)	
27A	002-164-12	Heat Shrink Tube (Sold per meter)	m	A4(d13x0.3t)	(Vm)	
	200-000-16	Electrical tape	1	N tape(0.5x19x10M)		
	200-000-17	Electrical tape	1	S tape(0.2x19x10M)		
28	002-140-12	Heat Shrink Tube (Sold per meter)	m	ST-110DG(d19)	(Vm)	
29	143-041-12	Pan Screw	1	M6x8	SWRM	
30	009-106-17	Terminal	2	R-8-6	CU	
31	140-076-17	Hex.Bolt	4	M10x30	SUS304	
32	142-164-19	Spring Washer	4	M10	SUS304	
33	214-008-10	Blind Cover	1		FC	
34	122-132-16	O-Ring	1	G-105(104.4xd3.1)	NBR	*
35	140-427-17	Hex.Bolt (w/Plain Washer)	2	M5x15	SUS304	

PARTS LIST		CONTRACTOR PUMPS				8/5/2019
ITEM	PART No.	DESCRIPTION	QTY	SIZE	MATERIAL	NOTES
36	003-175-19	Blind Cover	1	LB	SUS304	
37	121-000-01	Packing (Blind Cover)	1	LB	NBR	
38	011-101-19	Shackle	1	6mm	SS	
39	095-100-18	Chain	1	d5(9-Link)	SS	
40	072-108-44	Eye Bolt	2	M30	SS	
41	140-052-17	Hex.Bolt	2	M8x16	SUS304	
42	142-163-18	Spring Washer	2	M8	SUS304	
43	046-000-05	Air Release Valve	1	GSZ/NKZ/B	SPCC	
44	121-151-18	Packing	1	P.C.80xd50	CR	*
45	203-058-11	Ball	1	d28	SS	
47	142-165-10	Spring Washer	6	M12	SUS304	
48	142-000-47	Washer	6	M12(d12.5xd25.5x5t)	SUS304	
49	121-513-12	Seal Packing	6	d11.5xd21x4t	CR	*
50	217-000-21	Fixing Plate	1	GSZ-37/45KW,U-30/37KW	FC	
51	122-359-11	O-Ring	1	445xd5.7	NBR	*
52	122-353-15	O-Ring	1	310xd5.7	NBR	*
53	140-100-11	Hex.Bolt	6	M12x45	SUS304	
54	142-165-10	Spring Washer	6	M12	SUS304	
55	035-113-18	Air Tightness Test Plug	1	M12x14	SUS304	
56	121-247-12	Packing	1	d12.3xd18x2t	PE	*
57	050-000-75	Motor Bracket	1		FC	
58	122-353-15	O-Ring	1	310xd5.7	NBR	*
59	142-000-73	Wave Washer	1	6310(d109xd92x7Hx1.2t)	SK5	
60	052-000-50	Bearing (w/O-ring)	1	AC-6310ZZC3		
61	016-000-04	Lead Wire Protection Bush	2	d21xd52x11t	SBR	
62	058-000-23	Lead Wire Protection Plate	1	d120xd315x3t	SPCC	
63	065-000-52	Outer Cover	1	U/GSZ-6P*37/4P*45Ö³.600L	SGP	
64	055-002-00	Rotor	1Set			
65	147-000-38	Impeller Key	1	16x10x65L	SUS420	
66	053-001-67	Motor Protector	3	YS11A135A-D20	(H)	
67	056-005-46	Stator 460V-60Hz(USA)	1Set			
	056-005-48	Stator 575V-60Hz(USA)	1Set			
68	064-001-06	Motor Frame	1		FC	
69	142-427-13	Seal Washer	2	WD-12	SPC+NBR	
70	140-000-69	Hex.Bolt	2	M12x25	SS	
71	140-128-15	Hex.Bolt	6	M16x60	SUS304	
72	142-166-11	Spring Washer	6	M16	SUS304	
73	122-308-15	O-Ring	1	320xd5.7	NBR	*

PARTS LIST		CONTRACTOR PUMPS				8/5/2019
ITEM	PART No.	DESCRIPTION	QTY	SIZE	MATERIAL	NOTES
74	140-000-68	Hex.Bolt	4	M8x20	SS	
75	062-000-15	Bearing Fixing Plate	1	6315(PC185)	SS	
76	061-000-05	Slinger	1	6315/7315	SS	
77	052-000-06	Bearing	1Set	6315ZZD2C3		
78	142-248-18	Bearing Washer	1	AW15	SPCC	
79	141-080-17	Bearing Nut	1	AN15	SS	
80	122-359-11	O-Ring	1	445xd5.7	NBR	*
81	140-130-10	Hex.Bolt	6	M16x70	SUS304	
82	142-166-11	Spring Washer	6	M16	SUS304	
83	060-001-05	Bearing Housing	1		FC	
84	122-259-10	O-Ring	2	12xd3	NBR	*
85	035-102-30	Oil Plug	2	M12x16(B=21)	SUS304	
86	122-266-10	O-Ring	1	460xd6	NBR	*
87	025-001-18	Mechanical Seal	1	H-60 (RoHS)	SiC	replaces OLD part# 025-000-51
88	143-028-13	Pan Screw	3	M5x10	SWRM	
89	030-134-10	Oil Lifter	1	H-60	SPCC	
90	122-265-19	O-Ring	1	335xd5.7	NBR	*
91	029-146-11	Oil Casing	1	GSZ-45-4	FC	
92	122-314-14	O-Ring	1	341xd5.7	NBR	*
93	142-165-10	Spring Washer	6	M12	SUS304	
94	140-098-15	Hex.Bolt	6	M12x35	SUS304	
95	026-118-15	Oil Seal	1	TC-709513	NBR	
96	140-096-13	Hex.Bolt	6	M12x25	SUS304	
97	028-000-16	Seal Housing	1	GSZ2-45-4	FC	
98	122-261-15	O-Ring	1	255xd3.8	NBR	*
99	026-118-15	Oil Seal	1	TC-709513	NBR	
100	071-000-32	Spacer	1	d72xd95x9t	SUS403	
101	026-118-15	Oil Seal	2	TC-709513	NBR	
102	071-000-13	Shaft Sleeve	1	GSZ3-37-4(H)	SUS403	
103	020-344-14	Pump Casing	1	GSZ-45-4	FC	
104	021-002-37	Impeller (60Hz)	1	GSZ4-45-4	HiCrFC	
105	142-136-12	Plain Washer	1	M42	SUS304	
106	142-173-11	Spring Washer	1	M42	SUS304	
107	157-007-19	Impeller Nut	1	M42,P4.5,H=60	SS	
108	122-315-15	O-Ring	1	405xd5	NBR	*
109	022-178-24	Suction Cover	1	GSZ-37-4	FC	
110	142-166-11	Spring Washer	8	M16	SUS304	
111	140-124-11	Hex.Bolt	8	M16x40	SUS304	

PARTS LIST		CONTRACTOR PUMPS				8/5/2019
ITEM	PART No.	DESCRIPTION	QTY	SIZE	MATERIAL	NOTES
112	023-185-14	Strainer Stand	1	GSZ-37-4	SS	
113	142-166-11	Spring Washer	8	M16	SUS304	
114	140-124-11	Hex.Bolt	8	M16x40	SUS304	
115	037-147-17	Flanged Discharge Pipe	1Set	200mm(GS-37-6)	SGP	
116	140-148-11	Hex.Bolt	8	M20x50	SUS304	
117	142-168-13	Spring Washer	8	M20	SUS304	
118	121-166-29	Packing	1	JIS5Kx200mm	NR	
		<b>NPT Flange Version</b>				
	048-000-52	Screwed Flange	1	NPT-8(JIS10K)	FC	
	140-155-11	Hex.Bolt	8	M20x85	SUS304	
	141-009-12	Hex.Nut	8	M20	SUS304	
	142-168-13	Spring Washer	8	M20	SUS304	
	121-109-24	Packing	1	JIS10Kx200mm	NR	
	173-003-56	<b>Packing O-Ring Set</b>	1Set	(Marked by *)		
11	122-132-16	O-Ring (S.Box)	2	G-105(104.4xd3.1)	NBR	*
38	121-151-18	Packing (Air Release Valve)	1	P.C.80xd50	CR	*
43	121-513-12	Seal Packing (Fixing Plate Bolt)	6	d11.5xd21x4t	CR	*
45	122-359-11	O-Ring (Fixing Plate/Out.Cover)	1	445xd5.7	NBR	*
46	122-353-15	O-Ring (Fixing Plate/M.Bracket)	1	310xd5.7	NBR	*
50	121-247-12	Packing (Air Tightness Test Plug)	1	d12.3xd18x2t	PE	*
52	122-353-15	O-Ring (M.Frame/M.Bracket)	1	310xd5.7	NBR	*
67	122-308-15	O-Ring (M.Frame/Brg.Housing)	1	320xd5.7	NBR	*
74	122-359-11	O-Ring (Out.Cover/Brg.Housing)	1	445xd5.7	NBR	*
78	122-259-10	O-Ring (Oil Plug)	2	12xd3	NBR	*
80	122-266-10	O-Ring (Brg.Housing/P.Casing)	1	460xd6	NBR	*
84	122-265-19	O-Ring (Brg.Housing/O.Casing)	1	335xd5.7	NBR	*
86	122-314-14	O-Ring (O.Casing/P.Casing)	1	341xd5.7	NBR	*
92	122-261-15	O-Ring (Seal Housing/P.Casing)	1	255xd3.8	NBR	*
102	122-315-15	O-Ring (P.Casing/S.Cover)	1	405xd5	NBR	*
112	121-166-29	Packing (Flanged Discharge Pipe)	1	JIS5Kx200mm	NR	*
		Lubricant		Turbine Oil VG32 8,000ml		
	183-004-17	Impeller Puller (M10)	1	B No.4	FCD	7260

PARTS LIST		CONTRACTOR PUMPS				8/5/2019
ITEM	PART No.	DESCRIPTION	QTY	SIZE	MATERIAL	NOTES

## EXPLODED VIEW

GSZ4-45-4

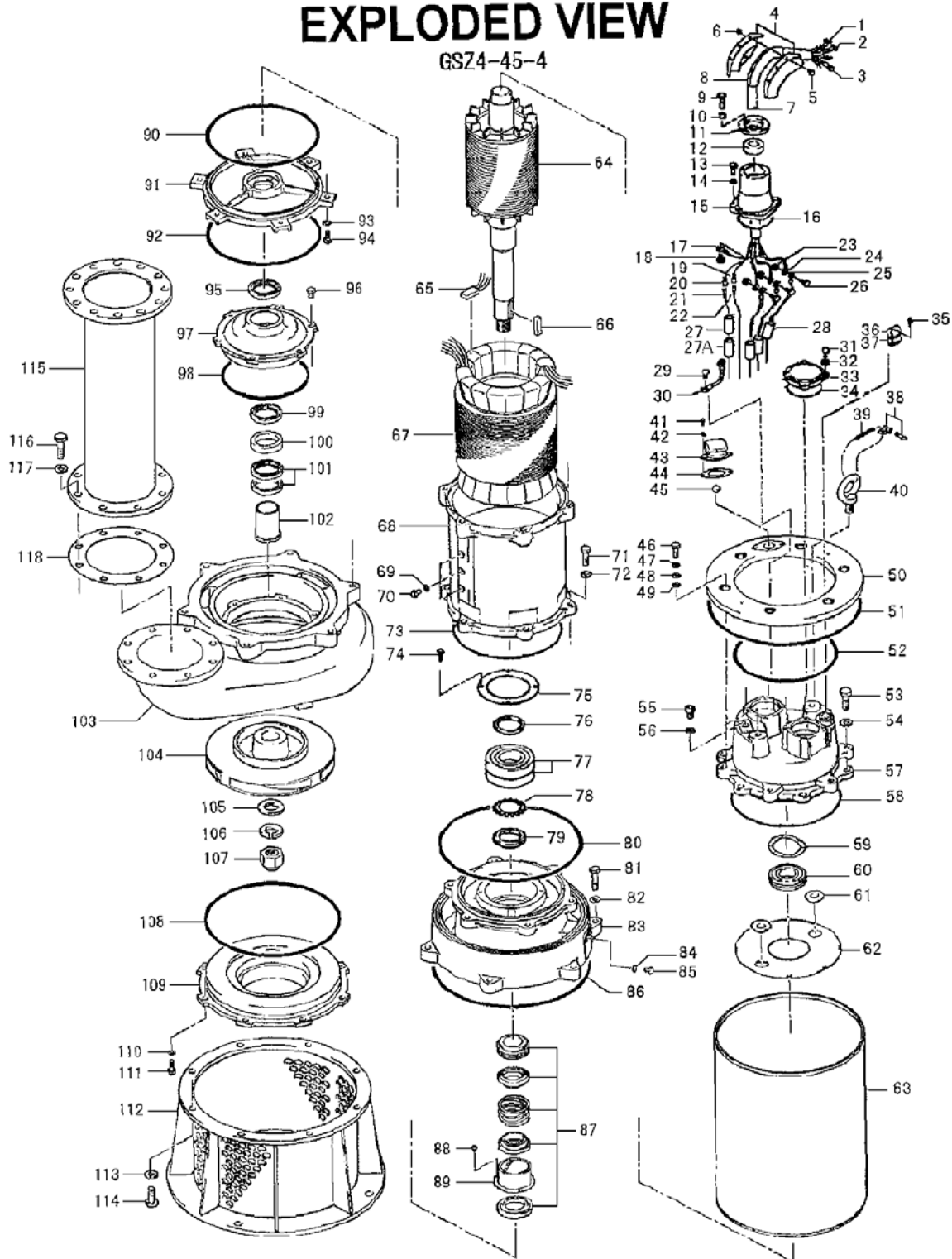

C-01464-1