

FEATURES

1. Semi-open, Mixed Flow, impeller, with replaceable adjustable wear plate, increases wear resistance when pumpage contains abrasive particles.
2. Double inside mechanical seals with silicon carbide faces, (both top and bottom) running in an oil filled chamber and further protected by a lip seal running against a replaceable, 430 stainless steel shaft sleeve, provides for the most durable seal design available.
3. Highly efficient, continuous duty air filled, copper wound motor with class E, B, F insulation minimizes the cost of operation.
4. Double shielded, permanently lubricated, high temperature C3 ball bearings, rated for a B-10 life of 60,000 hours, extend operational life.

5. Top discharge, flow-thru design enables operation at low water levels for extended periods.
6. 4 - pole motor increases product life and offers greater convenience.
7. Agitator installed on the motor shaft extension forcibly agitates the fluid for easy and efficient transmission of sludge and slime. (KRS2-80/-100/-150/KRS-200/KRS822L-SK))

APPLICATIONS

1. Commercial, industrial wastewater and construction site drainage.
2. Effluent transfer.
3. Decorative waterfalls and fountains.
4. Raw water supply from rivers or lakes.



SPECIFICATIONS

- Discharge Size
- Horsepower Range
- Performance Range Capacity Head
- Maximum water temperature
- Materials of Construction
 - Casing
 - Impeller
 - Agitator
 - Shaft
 - Motor Frame
 - Fasteners
- Mechanical Seal
 - Elastomers
- Impeller Type
- Solids Handling Capability
- Bearings
- Motor Nomenclature
 - Type, Speed, Hz.
 - Voltage, Phase
 - Insulation
- Accessories
- Operational Mode

STANDARD

- 3 ~ 14" NPT (80 ~ 350 mm)
- 3 ~ 50 HP. (2.2 ~ 37 kW)
- 66.0~4359.0 GPM. (0.25~16.50 m³/min)
- 16.4 ~ 113.0 Ft. (5.0 ~ 34.4 m)
- 104 °F. (40 °C.)
- Cast Iron
- Ductile Cast Iron , High Chrome Cast Iron (KRS2-80/-100/-150/KRS-200/KRS822L-SK)
- 420 Stainless Steel
- Cast Iron
- 304 Stainless Steel
- Silicon Carbide
- NBR (Nitrile Butadiene Rubber)
- Semi-open , Mixed Flow ,with Agitator 0.472 - 1.97" (12.0 - 50.0mm)
- Prelubricated, Double Shielded
- Air Filled, 1800 RPM, 60 Hz.
- 208/230/460/575 V., 3 Phase
- Class E, F, B
- Submersible Power Cable 50' (15.0 m)
- Manual

OPTIONS

- Length as Required
- TS-301 Float Switch



KRS - SERIES

HIGH VOLUME - DEWATERING & AGITATOR PUMPS

PERFORMANCE
CURVE

GROUP PERFORMANCE RANGE

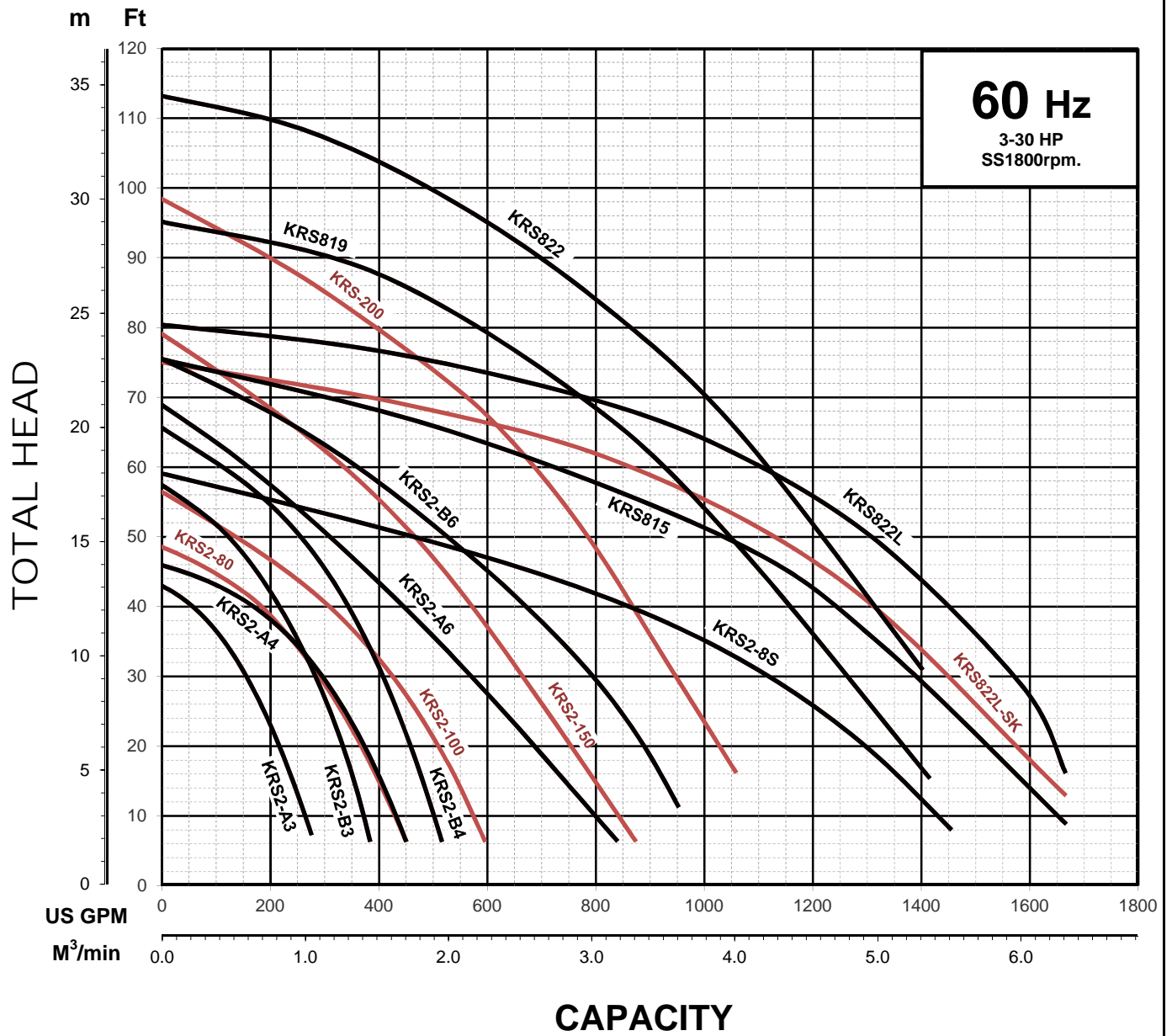

Note

[Empty box for notes]



KRS SERIES
HIGH VOLUME - AGITATOR PUMPS

DIMENSIONS

KRS-200

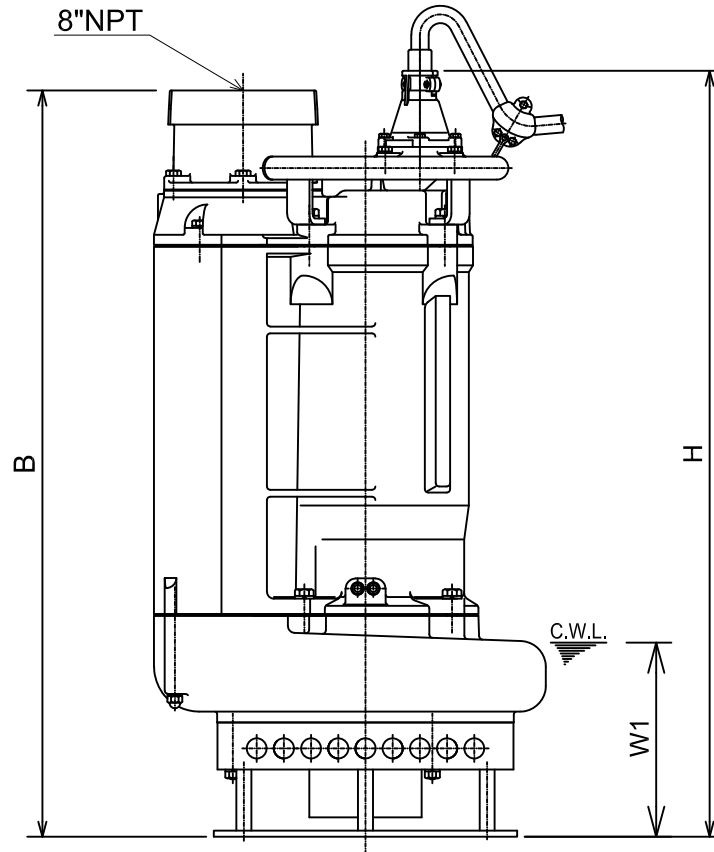
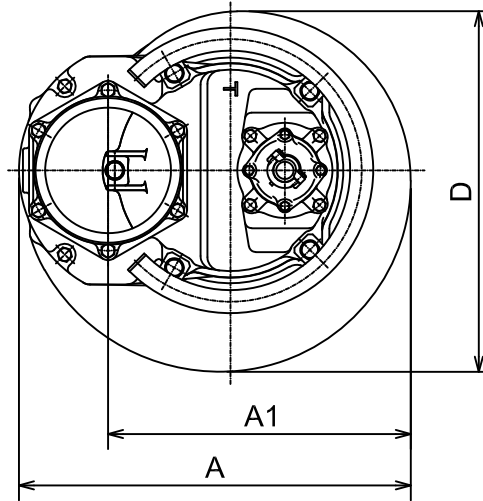

C.W.L. :Continuous running Water Level

DIMENSIONS:USCS(Inch)

Model	HP	NOM. SIZE	Pump & Motor					C.W.L.	*Wt. (lbs.)
			A	A1	B	D	H	W1	
KRS-200	30	8"	22 11/16	17 1/2	43 3/16	20 3/4	44 5/16	11 1/4	840

*Excluding Cable

DIMENSIONS:METRIC(mm)

Model	kW	NOM. SIZE	Pump & Motor					C.W.L.	*Wt. (kg)
			A	A1	B	D	H	W1	
KRS-200	22	200	576	445	1097	530	1126	285	380



KRS - SERIES

HIGH VOLUME - AGITATOR PUMPS

PERFORMANCE
CURVE

MODEL	BORE	HP	KW	RPM	SOLIDS DIA.	LIQUID	SG.	VISCOSITY	TEMP.
KRS-200	8"/200mm	24	18	1750	1.18"/30mm	Water	1.0	1.123cSt.	60°F
PUMP TYPE	PHASE	VOLTAGE	AMPERAGE	HZ	STARTING METHOD	INS. CLASS			
High Volume - Agitator Pump	3	460 / 575	30 / 24	60	Direct On Line	F			
CURVE No.	DATE	PHASE	VOLTAGE	AMPERAGE	HZ	STARTING METHOD	INS. CLASS		
-	-	-	-	-	-	-	-		

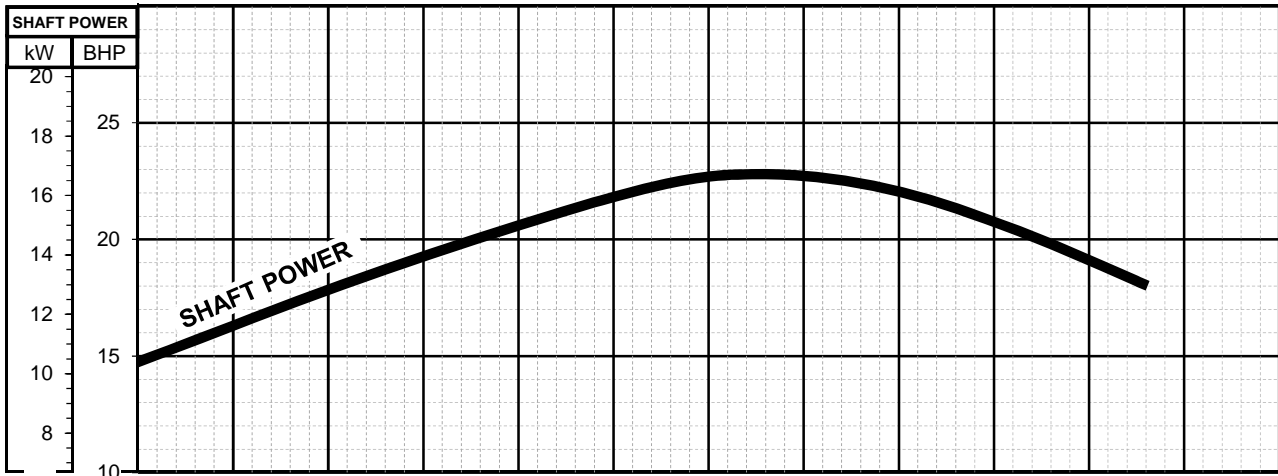
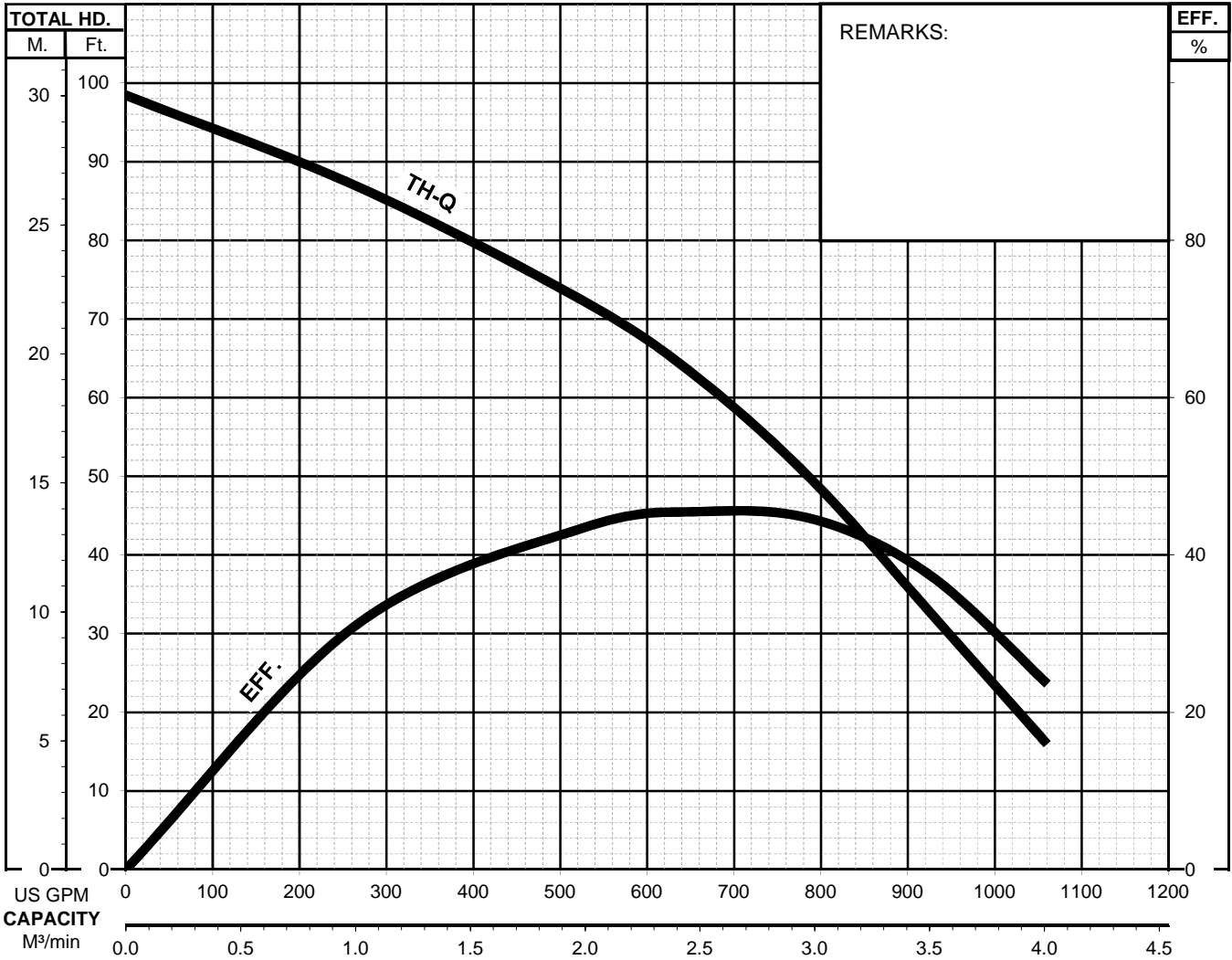



**KRS SERIES
HIGH VOLUME AGITATOR PUMPS**

SECTIONAL VIEW

KRS-200

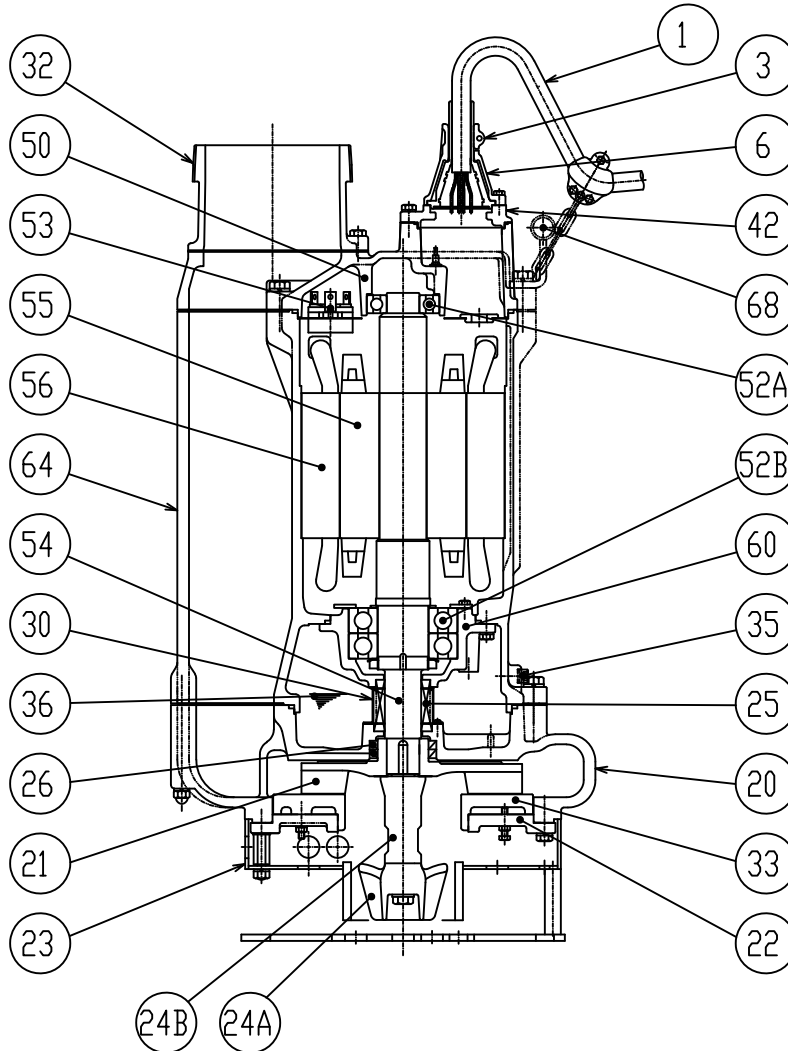

PART#	DESCRIPTION	MAIN MATERIAL / NOTE	RELATED ASTM,AISI CODE	RELATED EN CODE	QTY
1	Power Cable	Chloroprene Sheath AWG 6/4 -50ft			1
3	Gland	Cast Iron	A48M Class30B	EN 1561 GJL-200	1
6	Stuffing Box	Cast Iron	A48M Class30B	EN 1561 GJL-200	1
20	Pump Casing	Cast Iron	A48M Class30B	EN 1561 GJL-200	1
21	Impeller	High Chrome Cast Iron	A532 Class III TypeA	DIN 1695 G-X260Cr27	1
22	Suction Cover	Cast Iron	A48M Class30B	EN 1561 GJL-200	1
23	Suction Strainer	Steel (Cold Rolled) + Steel Pipe	A109/A1008 + A53 Type F	EN 10130 + DIN 1615 St33	1
24A	Agitator	High Chrome Cast Iron	A532 Class III TypeA	DIN 1695 G-X260Cr27	1
24B	Clutch	Malleable Cast Iron (Hardened)	A47M Grade 22010	EN 1562 GJMB-350-10	1
25	Mechanical Seal	Silicon Carbide / H-50X			1
26	Oil Seal	NBR / TC709212			2
30	Oil Lifter	Steel (Cold Rolled)	A109/A1008	EN 10130	1
32	Discharge Connection	Cast Iron / NPT 8"	A48M Class30B	EN 1561 GJL-200	1
33	Suction Plate	High Chrome Cast Iron	A532 Class III TypeA	DIN 1695 G-X260Cr27	1
35	Oil Plug	Stainless Steel	S 30400	1.4301	2
36	Lubricant	Turbine Oil ISO VG32 or SAE 10W-20			
42	Stuffing Box Sheet	Cast Iron	A48M Class35B	EN 1561 GJL-250	1
50	Motor Bracket	Cast Iron	A48M Class35B	EN 1561 GJL-250	1
52A	Upper Bearing	#6309ZZC3			1
52B	Lower Bearing	#6314ZZD2C3			1
53	Motor Protector				3
54	Shaft	Stainless Steel	S 42000	1.4021	1
55	Rotor				1
56	Stator				1
60	Bearing Housing	Cast Iron	A48M Class30B	EN 1561 GJL-200	1
64	Motor Housing	Cast Iron	A48M Class30B	EN 1561 GJL-200	1
68	Handle	Steel Pipe + Steel	A53 Type F + A283 Grade D	DIN 1615 St 33 + EN 10025 S275	1

TSURUMI PUMP
**KRS - SERIES
HIGH VOLUME - DEWATERING PUMPS**
**SAMPLE
SPECIFICATIONS**

1. SCOPE OF SUPPLY -

Furnish and install TSURUMI Model _____ Submersible Pump(s). Each unit shall be capable of delivering _____ GPM (_____ m³/min) at _____ Feet (_____ m) TDH. The pumps shall be designed to pump waste water, without damage during operation. The pump(s) shall be designed so that the shaft power required (BHP)/(kW) shall not exceed the motor rated output throughout the entire operating range of the pump performance curve. Pump(s) shall be of the top discharge flow through design.

2. MATERIALS OF CONSTRUCTION -

Construction of major parts of the pumping unit(s) shall be as follows: Pump casing shall be gray cast iron, ASTM A48 CLASS 30B. Motor frame shall be gray cast iron. Field adjustable/replaceable wear plate shall be gray cast iron, ASTM A48 CLASS 30B or high chrome cast iron (40 HP and above). Impellers on units up to 30 HP / 8" bore shall be of the multi-vane semi-open design, and shall be ductile cast iron (ASTMA536 100-70-03). Impeller on KRS1022 shall be of the multi-vane enclosed design, and shall be ductile cast iron (ASTMA536 100-70-03). Impellers on KRS-1230/1437 shall be of the multi-vane semi-open design, and shall be high chrome cast iron. Impellers shall be equipped with back pump out vanes, slip fit to the shaft and key driven. Internal and external surfaces coming into contact with the pumpage shall be protected by a fused polymer coating. All exposed fasteners shall be stainless steel. All units shall be furnished with _____" NPT discharge connector.

3. MECHANICAL SEAL -

All units shall be furnished with a dual inside mechanical shaft seal located completely out of the pumpage, running in a separate oil filled chamber and further protected by an exclusionary oil seal located between the bottom seal faces and the fluid being pumped. The oil chamber shall be fitted with a device that shall provide positive lubrication of the top mechanical seal, (down to one third of the standard oil level). The device shall not consume any additional electrical power. Mechanical seals shall rated to preclude the incursion of water up to 42.6 PSI. (98.4 Ft.) submergence. Units shall be have silicon carbide upper and lower mechanical seal faces. Mechanical seal hardware shall be stainless steel.

4. MOTOR-

The pump motor(s) shall be _____ HP., _____ kW., _____ V., 60 Hz. 3 Phase and shall be NEMA MG-1, Design Type B equivalent. Motor(s) shall be rated at _____ full load amps. Motor(s) shall have a 1.15 service factor and shall be rated for 20 starts per hour. Motor(s) shall be air filled, copper wound, class F, B or E insulated with built in thermal protection for each winding. Motor shaft shall be 420 stainless steel, fitted with a replaceable 403 stainless steel shaft sleeve and shall be supported by two permanently lubricated, high temperature ball bearings, with a B-10 life rating at best efficiency point of 60,000 hours. Bearings on units up to 20 Hp shall be single row, double shielded, C3, deep groove type ball bearing. On units 25 Hp. (19 kW) and above, the bottom bearing shall be two row, double shielded, C3, deep groove type ball bearing, and the top bearing shall be single row, double shielded, C3, deep groove type ball bearing. Motors shall be D.O.L. or star-delta start (40 and 50 Hp), and shall be suitable for across the line start or variable speed applications, utilizing a properly sized variable frequency drive.

5. POWER CABLE AND CABLE ENTRANCE -

The pump power cable shall be suitable for submersible pump applications and shall be field replaceable utilizing standard submersible pump cable. The cable entrance shall incorporate built in strain relief and a combination three way mechanical compression sealing with a fatigue reducing boot (up to 30 Hp). The cable entrance assembly shall contain a anti-wicking block to eliminate water incursion into the motor due to capillary wicking should the power cable be accidentally damaged.