

Newly designed SQ-series pumps, now lighter and easier to carry!

SQ



SQA

Automatic model



SQ/SQA SERIES

The SQ/SQA-series are submersible portable stainless steel corrosion-resistant pumps with vortex impellers. They are made of 304/316 stainless steel, Nitrile Butadiene Rubber and special resin to stand up to rust and corrosion, and sport a new structural design that makes them even lighter and easier to carry than before.

Both pumps feature a top discharge, flow-thru design with forced motor cooling that enables extended running at low water level. In addition to that, the SQ-series has a slim body that fits inside 8-inch pipe.

The SQA-series is an automatic model with two simple float switches that prevents dry-running and reduces power consumption.

Though compact in size, these pumps come packed with a number of original technologies developed and honed over years of service, including an anti-wicking cable, dual inside mechanical seals with silicon carbide face and an Oil Lifter. Moreover, liquid paraffin is used as a lubricant, so the pumps can be used in food and aquaculture applications. Designed and built for sound quality and continuous duty, Tsurumi's SQ/SQA-series pumps are highly reliable, durable and assuredly meet the needs of users who cannot afford rusting.

Features

1 Anti-wicking Cable Entry

Prevents water incursion due to capillary action should the cable sheath be damaged or the end of cable submerged. Also prevents moist air from infiltrating the motor housing and condensation from forming inside the housing due to temperature differences between the housing and outside air.

2 Motor Protector

Reacts to excessive heat caused by overcurrent or dry-running to protect pumps. It not only cuts off the motor circuit automatically but also resets by itself. When the motor cools down to a safe operating temperature, the motor restarts.

3 Dual Inside Mechanical Seals with Silicon Carbide Face

Isolated in the oil chamber where a clean, non-corrosive and abrasion-free lubricating environment is maintained. Compared with the water-cooled outside mechanical seal, it reduces the risk of failure caused by dry-heating and adhering matter. The silicon carbide provides 5 times higher corrosion, wear and heat resistance than the tungsten carbide.

4 Oil Lifter

Provides lubrication and cooling of the seal faces down to 1/3 of normal oil level, thus maintaining a stable shaft sealing effect and prolonging seal life longer. The Oil Lifter is Tsurumi original design.

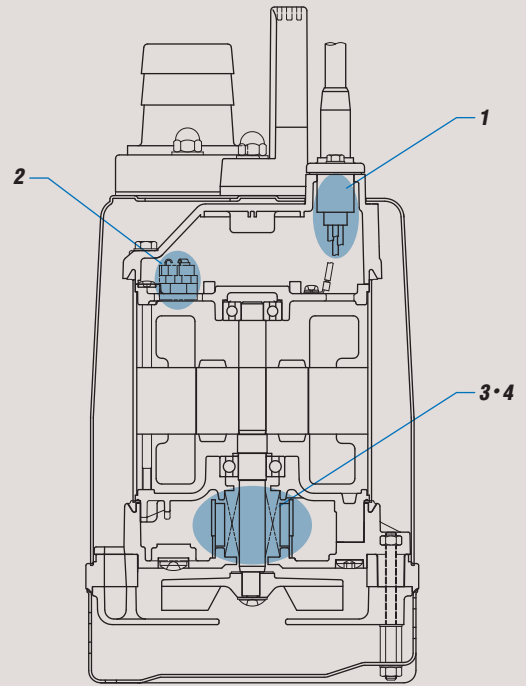

Performance Curves

Standard and Automatic models have the identical performance.

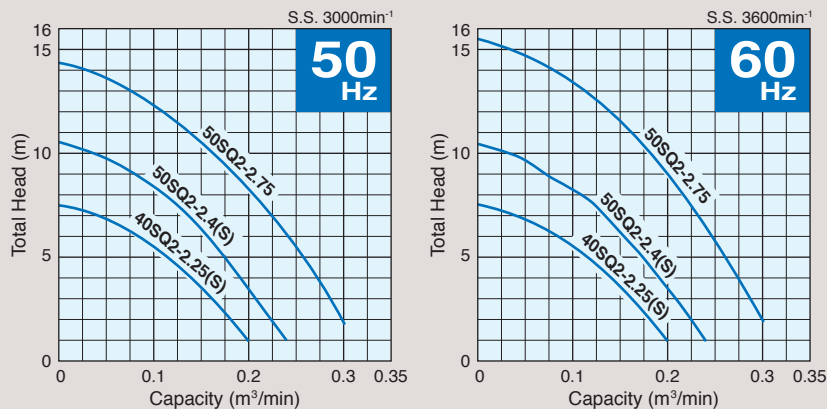

Dimensions

Unit: mm C.W.L.: Continuous Running Water Level

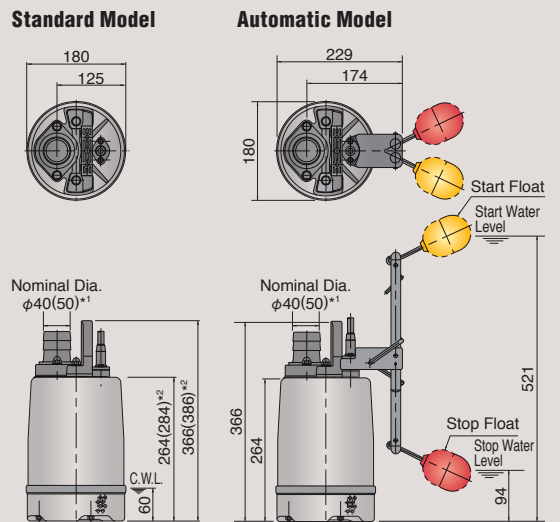

*1 The figure in parentheses is for 0.4 and 0.75kW models.
*2 The figure in parentheses is for 0.75kW model.

Model Selection

Discharge Bore mm	Model		Motor Output kW	Phase	Starting Method	Solids Passage mm	Dry Weight kg		Cable Length m
	Standard	Automatic					Standard	Automatic	
40	40SQ2-2.25S	40SQA2-2.25S	0.25	Single	Capacitor Run	6	10.5	11	5
40	40SQ2-2.25	—	0.25	Three	D.O.L.	6	10.5	—	5
50	50SQ2-2.4S	50SQA2-2.4S	0.4	Single	Capacitor Run	6	10.5	11	5
50	50SQ2-2.4	—	0.4	Three	D.O.L.	6	10.5	—	5
50	50SQ2-2.75	—	0.75	Three	D.O.L.	6	12	—	5

• Weights excluding cable

Product images and specifications may differ from actual products due to improvements. The OO series and model OO are indicated with our series/model codes in this catalog.

TSURUMI
MANUFACTURING CO., LTD.

www.tsurumi-global.com



Your Dealer

GROUP PERFORMANCE RANGE

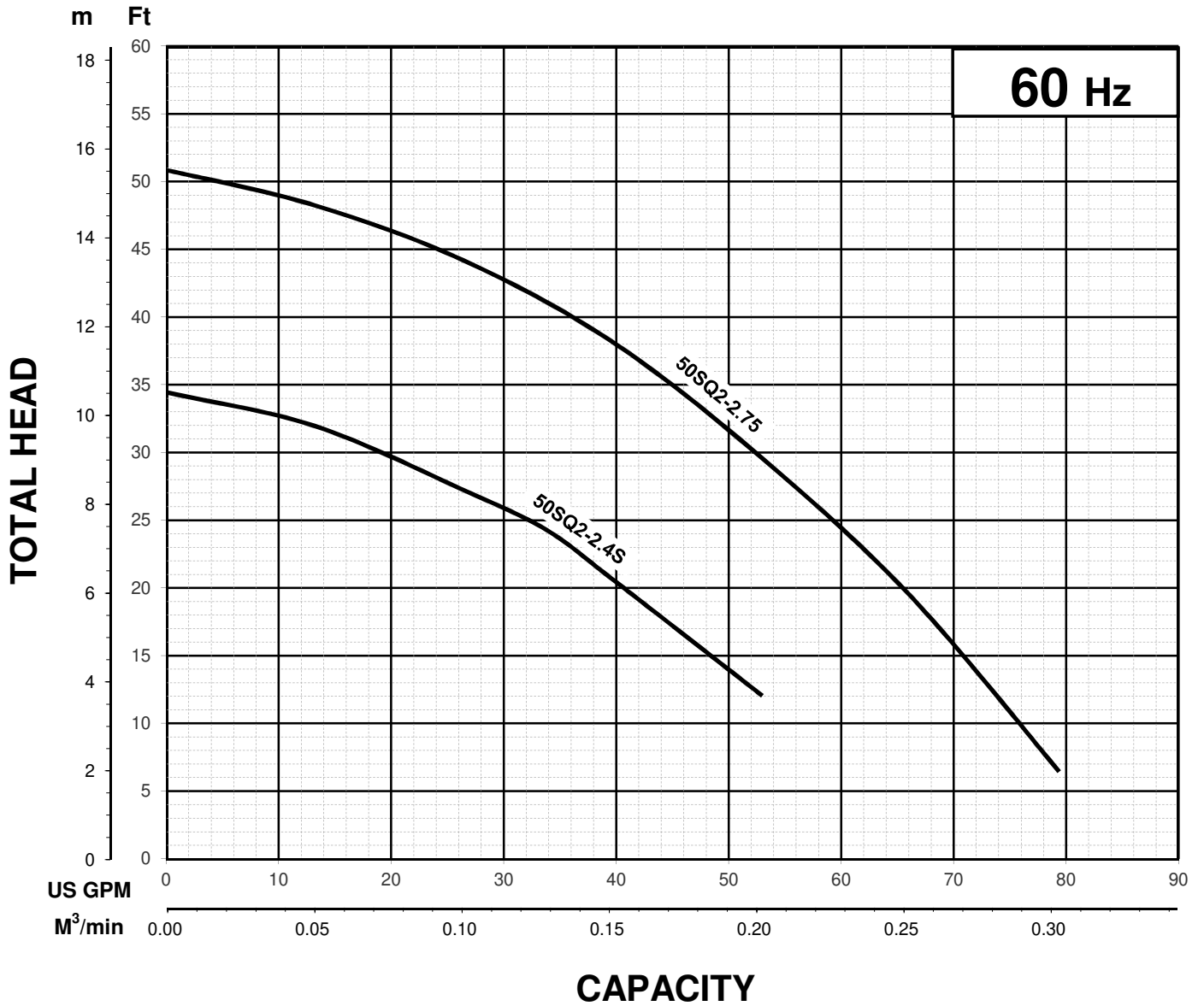

Note



SQ - SERIES

STAINLESS STEEL - DEWATERING PUMPS

PERFORMANCE CURVE

MODEL		BORE	HP	kW	RPM	SOLIDS DIA.	LIQUID	SG.	VISCOSITY	TEMP.
50SQ2-2.75-61		2"/50mm	1	0.75	3320	0.236"/6mm	Water	1.0	1.123cSt.	60°F
PUMP TYPE		PHASE	VOLTAGE		AMPERAGE		HZ	STARTING METHOD		INS. CLASS
Stainless Steel - Dewatering Pump		3	208-230/460/575		3.4-3.5 / 2.0 / 1.5		60	Direct On Line		E
CURVE No.	DATE	PHASE	VOLTAGE	AMPERAGE	HZ	STARTING METHOD		INS. CLASS		
-	-	-	-	-	-	-		-		

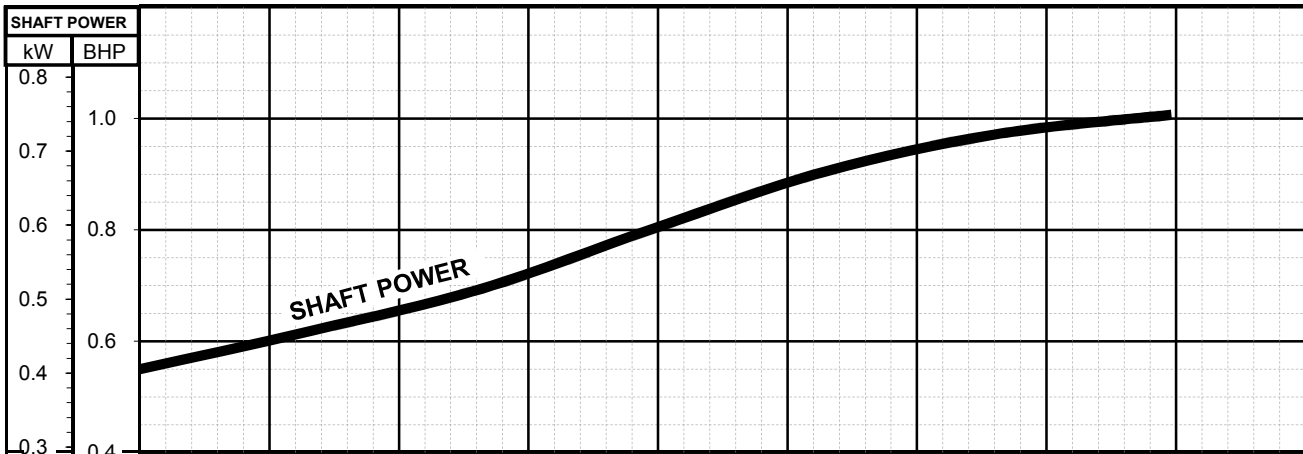
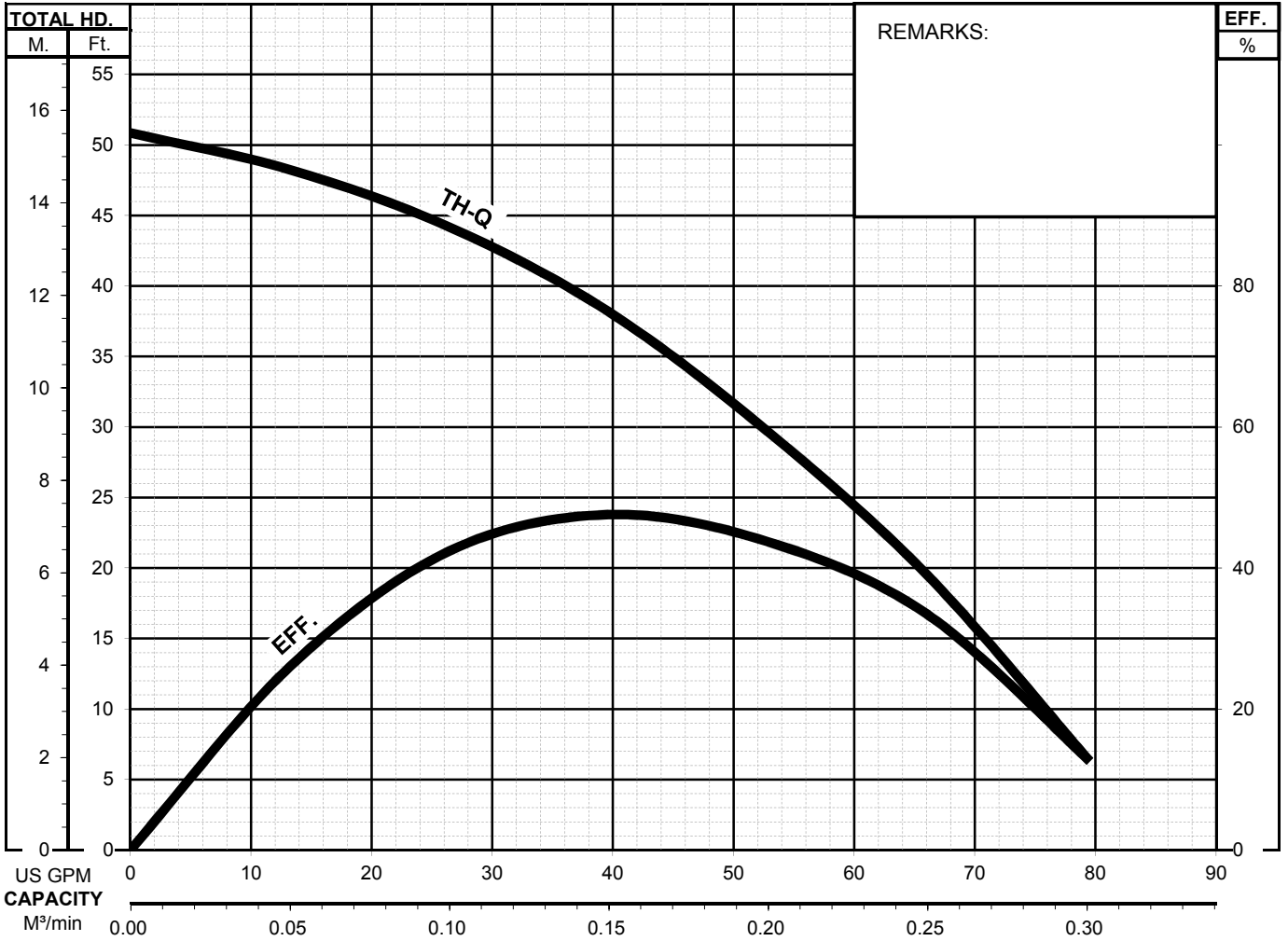

50SQ2-2.4S-61
50SQ2-2.75-61

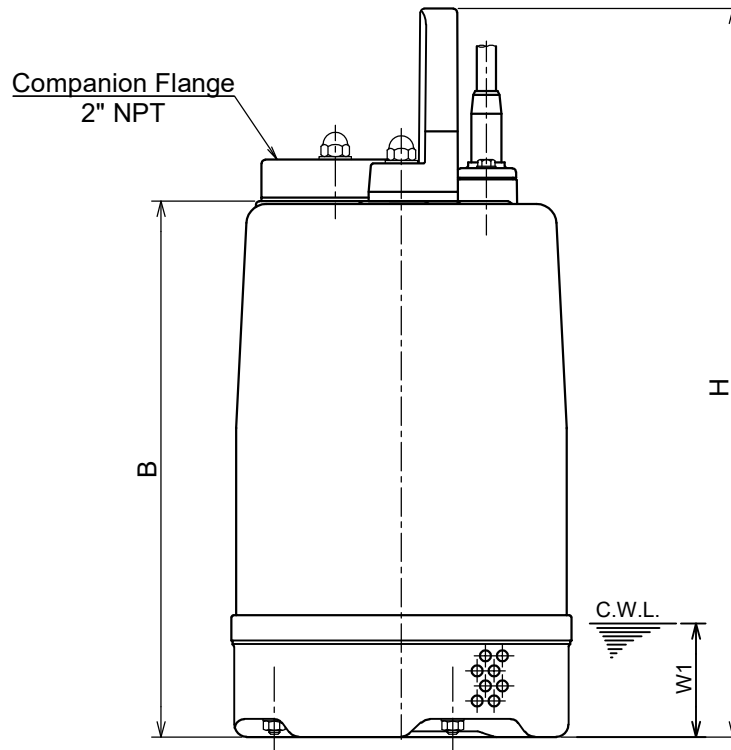
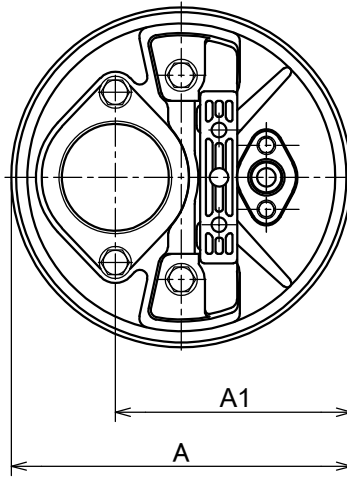

C.W.L. :Continuous running Water Level

DIMENSIONS:USCS (Inch)

Model	HP	NOM. SIZE	Pump & Motor				C.W.L. W1	*Wt. (lbs.)
			A	A1	B	H		
50SQ2-2.4S-62	1/2	2"	7 1/16	4 15/16	10 3/8	14 7/16	2 3/8	23
50SQ2-2.75-62	1	2"	7 1/16	4 15/16	11 3/16	15 3/16	2 3/8	26

DIMENSIONS:METRIC (mm)

*Excluding Cable

Model	kW	NOM. SIZE	Pump & Motor				C.W.L. W1	*Wt. (kg)
			A	A1	B	H		
50SQ2-2.4S-62	0.40	50	180	125	264	366	60	10.5
50SQ2-2.75-62	0.75	50	180	125	284	386	60	12

50SQ2-2.75-61

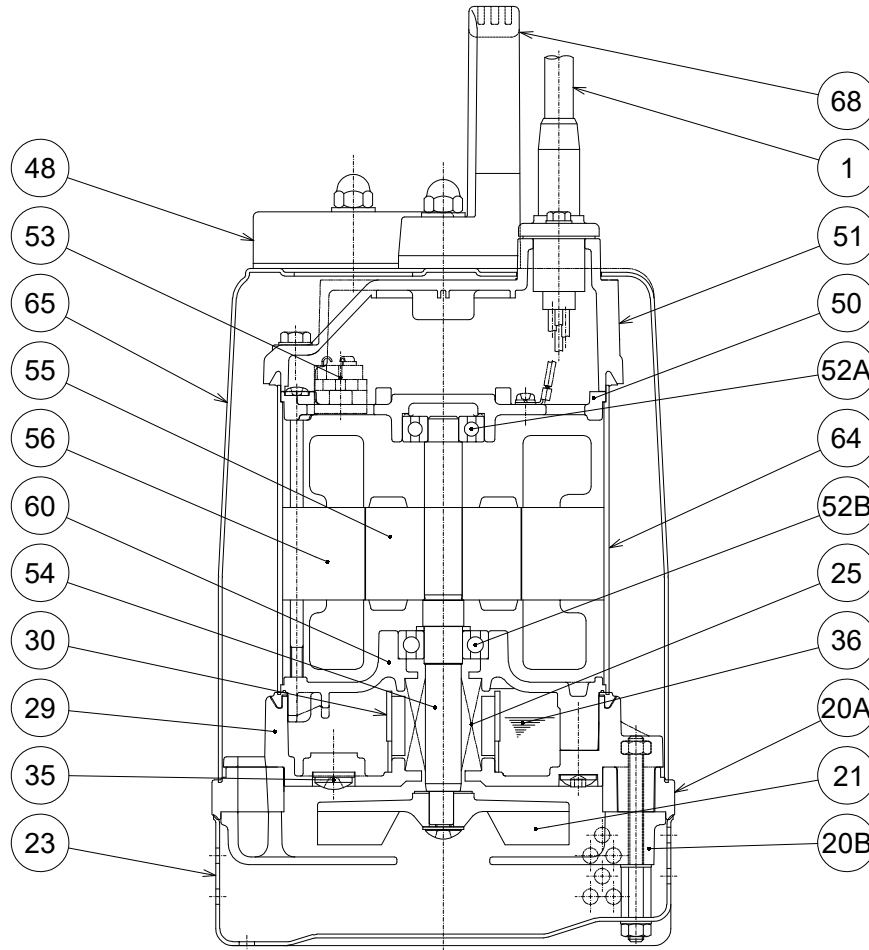

ITEM#	DESCRIPTION	MAIN MATERIAL / NOTE	ASTM, AISI CODE	RELATED EN CODE	Q'TY
1	Power Cable	PVC Sheath AWG16/4-32ft			1
20A	Upper Pump Casing	Nitrile Butadiene Rubber			1
20B	Lower Pump Casing	Stainless Steel Casting	A743 CF-8	17445 G-X6 CrNi 18-9	1
21	Impeller	PPO Plastic w/GF20			1
23	Strainer Stand	Stainless Steel	S 30400	1.4301	1
25	Mechanical Seal	Silicon Carbide / W-14HL			1
29	Oil Casing	PPS Plastic w/(GF+MD)50			1
30	Oil Lifter	PBT Plastic w/(GF+MD)40			1
35	Oil Plug	Stainless Steel	S 30400	1.4301	1
36	Lubricant	White Oil ISO VG32			
48	Companion Flange	PBT Plastic W/GF30 / NPT 2"			1
50	Motor Bracket	Aluminum Alloy Die Casting	B85 383.0	EN 1706 AC-46100	1
51	Motor Head Cover	PPS Plastic w/(GF+MD)50			1
52A	Upper Bearing	#6201ZZC3			1
52B	Lower Bearing	#6302ZZC3			1
53	Motor Protector				1
54	Shaft	Stainless Steel	S 30400	1.4301	1
55	Rotor				1
56	Stator				1
60	Bearing Housing	Aluminum Alloy Die Casting	B85 383.0	EN 1706 AC-46100	1
64	Motor Housing	Stainless Steel	S 30400	1.4301	1
65	Outer Cover	Stainless Steel	S 31600	1.4401	1
68	Handle	ABS Resin			1

TSURUMI PUMP
SQ - SERIES
ALL 304 SS - DEWATERING PUMPS
SAMPLE
SPECIFICATIONS
1. SCOPE OF SUPPLY -

Furnish and install TSURUMI Model _____ Submersible Pump(s).
 Each unit shall be capable of delivering _____ GPM (_____ m³/min) at _____ Feet (_____ m) TDH.
 The pump(s) shall be designed to pump waste water, without damage during operation. The pump(s) shall be designed so that the shaft power required (BHP)/(kW) shall not exceed the motor rated output throughout the entire operating range of the pump performance curve. Pump(s) shall be of the top discharge, flow through design.

2. MATERIALS OF CONSTRUCTION -

Construction of all parts of the pumping unit(s) shall be heavy gage fabricated 304 stainless steel. Impellers shall be of the multi-vane semi-open solids handling design, and shall be slip fit to the shaft and key driven. Internal and external surfaces coming into contact with the pumpage shall not require a protective coating. All exposed fasteners shall be stainless steel. All units shall be furnished with 2" NPT discharge connector. All surface materials and lubricant shall be non-toxic.

3. MECHANICAL SEAL -

All units shall be furnished with a dual inside mechanical shaft seal located completely out of the pumpage, running in a separate oil filled chamber. The oil chamber shall be fitted with a device that shall provide positive lubrication of the top mechanical seal, (down to one third of the standard oil level). The device shall not consume any additional electrical power. Mechanical seals shall be rated to preclude the incursion of water up to 42.6 PSI (98.4 Ft.) submergence. Units shall have silicon carbide mechanical seal faces. Mechanical seal hardware shall be stainless steel.

4. MOTOR-

The pump motor(s) shall be _____ HP., _____ kW., _____ V., 60 Hz. ___ Phase and shall be NEMA MG-1, Design Type B equivalent. Motor(s) shall be rated at _____ full load amps. Motor(s) shall have a 1.15 service factor and shall be rated for 20 starts per hour. Motor(s) shall be air filled, copper wound, class E insulated with built in thermal protection. Motor shaft shall be 304 stainless steel, shall be supported by two permanently lubricated, high temperature ball bearings, with a B-10 life rating at best efficiency point of 60,000 hours. Bearings on all units shall be single row, double shielded, C3, deep groove type ball bearing. Motors shall be suitable for across the line start or variable speed applications, utilizing a properly sized variable frequency drive.

5. POWER CABLE AND CABLE ENTRANCE -

The pump power cable shall be suitable for submersible pump applications. The cable entrance shall incorporate built in strain relief, and a one piece, three way mechanical compression seal with a fatigue reducing cable boot. The cable entrance assembly shall contain an anti-wicking block to eliminate water incursion into the motor due to capillary wicking should the power cable be accidentally damaged.