



UZ - SERIES
VORTEX - SEWAGE & WASTE WATER PUMPS

SPECIFICATIONS

■ FEATURES

1. Vortex , Cast Iron, impeller passes solids and stringy material without clogging and increases wear resistance when pumpage contains abrasive particles.
2. Double inside mechanical seals with silicon carbide faces, running in an oil filled chamber and further protected by a lip seal, provides for the most durable seal design available.
3. Highly efficient, continuous duty, air filled, copper wound motor with class F, insulation minimizes the cost of operation.
4. Built in thermal & amperage sensing, protector prevents motor failure due to overloading, single phasing (in three phase units), or accidental run -dry conditions.

5. Double shielded, permanently lubricated, high temperature C3 ball bearings rated for a B-10 life of 60,000 hours, extend operational life.

■ APPLICATIONS

1. Residential, commercial, industrial sewage, effluent, wastewater and site drainage.
2. Decorative waterfalls, fountains and fish ponds.
3. Raw water supply from rivers or lakes.

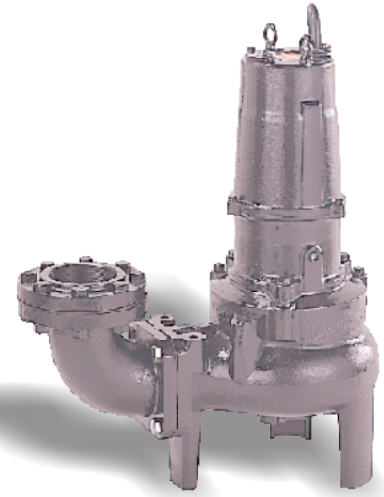

■ SPECIFICATIONS

- Discharge Size
- Horsepower Range
- Performance Range Capacity Head
- Maximum water temperature
- Materials of Construction
 - Casing
 - Impeller
 - Shaft
 - Motor Frame
 - Fasteners
- Mechanical Seal
 - Elastomers
- Impeller Type
- Solids Handling Capability
- Bearings
- Motor Nomenclature
 - Type, Speed, Hz.
 - Voltage, Phase
 - Insulation
- Accessories
- Operational Mode

■ STANDARD

- 2 ~ 4" Npt (50 ~ 100 mm)
- 2 ~15 Hp. (1.5 ~ 11 kW)
- 26.4 ~ 740.0 Gpm. (.1 ~ 2.8 m³/min)
- 8.2 ~ 70.0Ft. (2.5 ~ 21.3 m)
- 104 °F. (40 °C.)
- ASTM 48M Class 30B Cast Iron
- ASTM 48M Class 30B Cast Iron
- 420,403 Stainless Steel
- ASTM 48M Class 30B Cast Iron
- 304 Stainless Steel
- Silicon Carbide
- NBR (Nitril Buna Rubber)
- Vortex, solids handling.
- 1.97 ~ 3.94" (50 ~ 100 mm)
- Pre-lubricated, Double Shielded
- Air Filled, 1800 Rpm, 60 Hz.
- 208-230, 460 or 575 V. (3 Phase)
- Class E, F
- Submersible Power Cable 32' (10 m)
- Manual

■ OPTIONS

- Length as Required
- TOS Slide rail system

GROUP PERFORMANCE RANGE

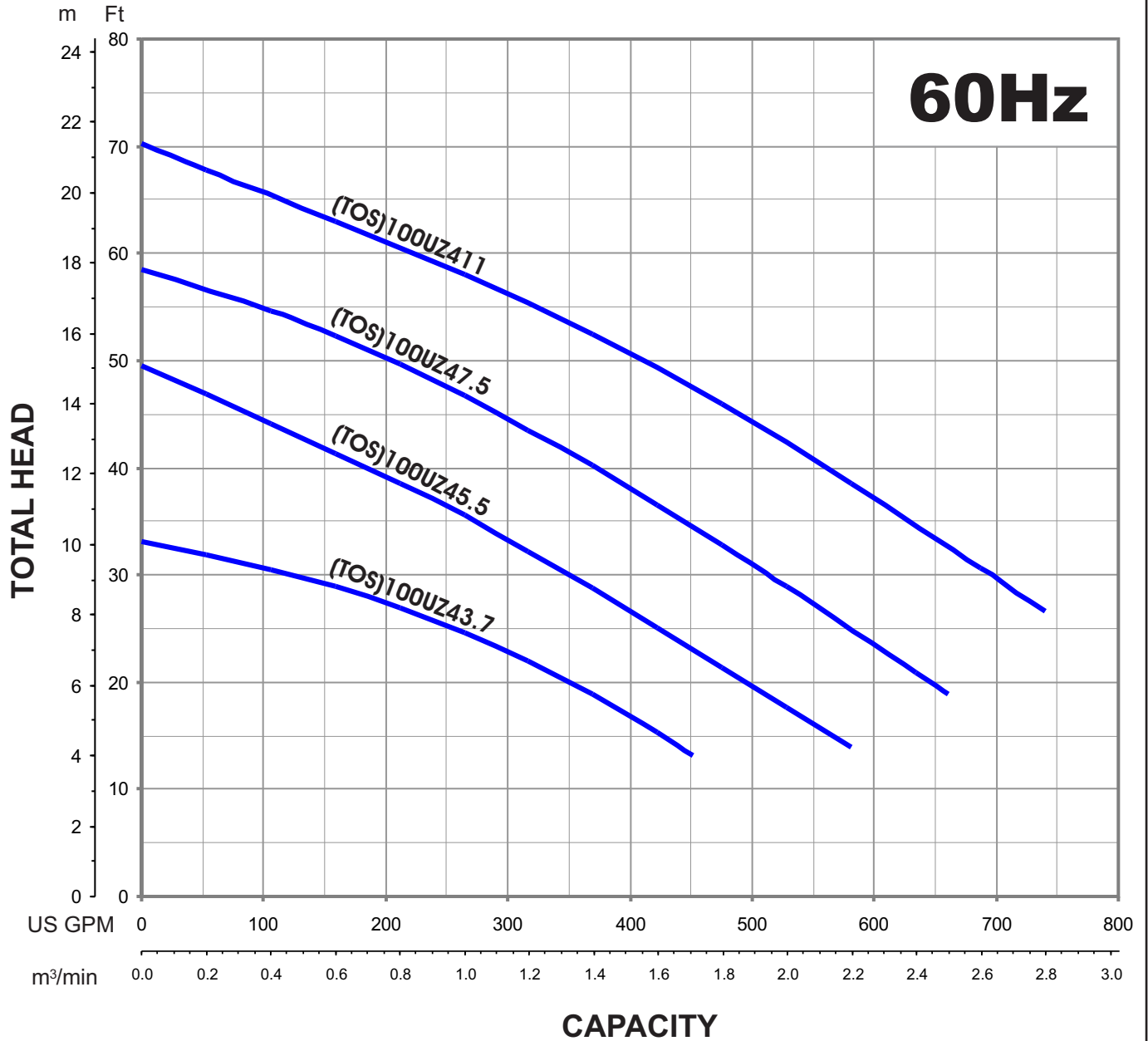



TSURUMI PUMP

**UZ-SERIES
VORTEX - SEWAGE & WASTEWATER PUMPS**

**PERFORMANCE
CURVE**

MODEL	BORE	HP	KW	RPM	SOLIDS DIA.	LIQUID	SG.	VISCOSITY	TEMP.
(TOS)100UZ45.5 -64	4"/100mm	7.5	5.5	1731	3.94"/100mm	Water	1.0	1.123cSt.	60°F
PUMP TYPE	PHASE	VOLTAGE	AMPERAGE	HZ	STARTING METHOD	INS.CLASS			
Vortex-Sewage&Wastewater	3	208-230/460/575	22.6-20.5/10.3/8.1	60	Direct On Line	F			
CURVE No.	DATE	PHASE	VOLTAGE	AMPERAGE	HZ	STARTING METHOD	INS.CLASS		
-	-	-	-	-	-	-	-		

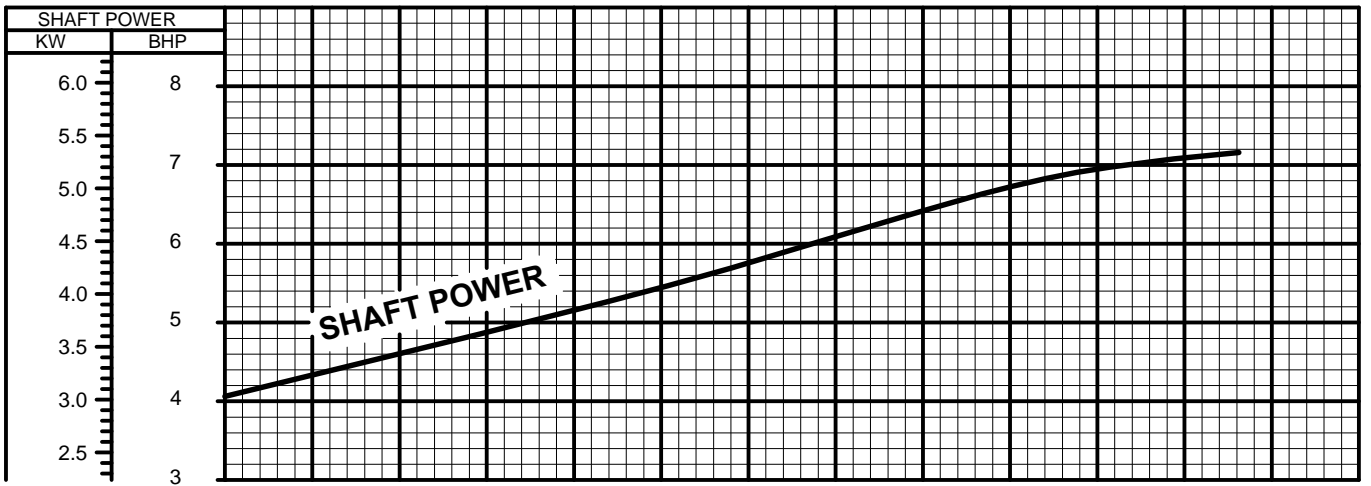
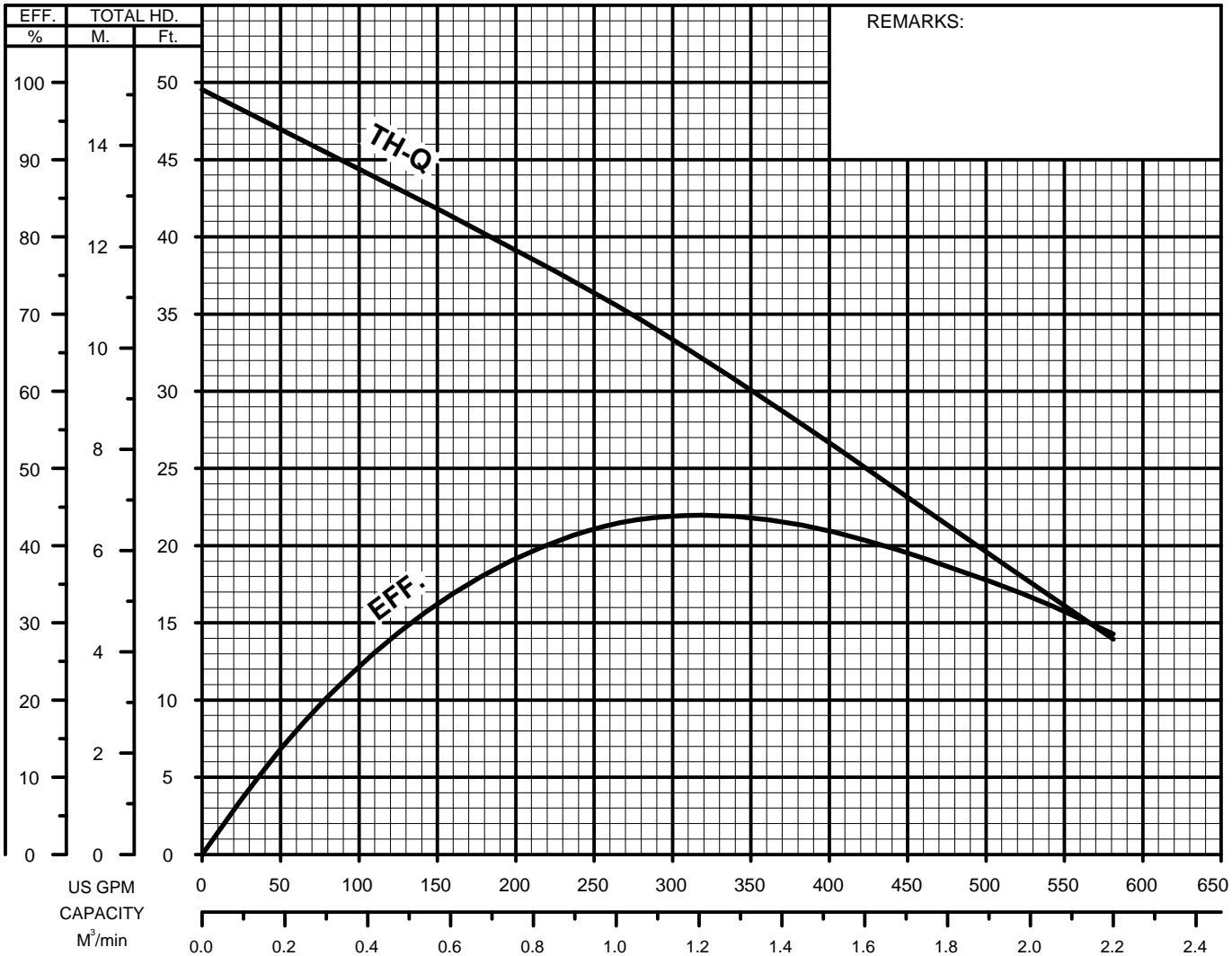

Bend model:
BEND 100-100 ANSI

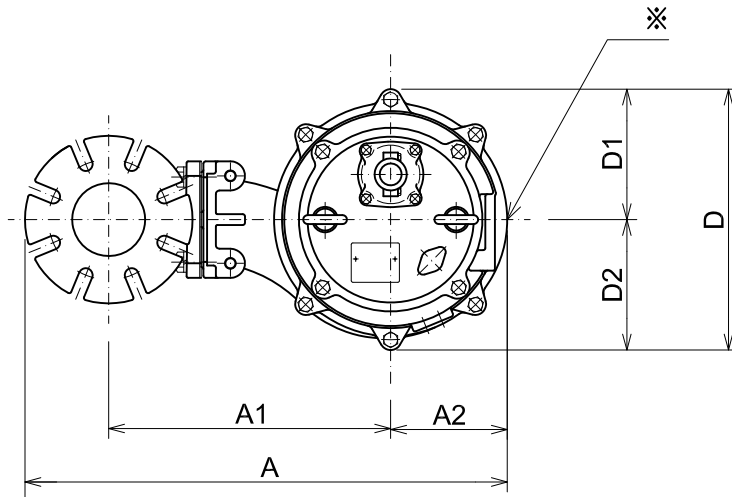

100UZ45.5 -64
100UZ47.5 -64

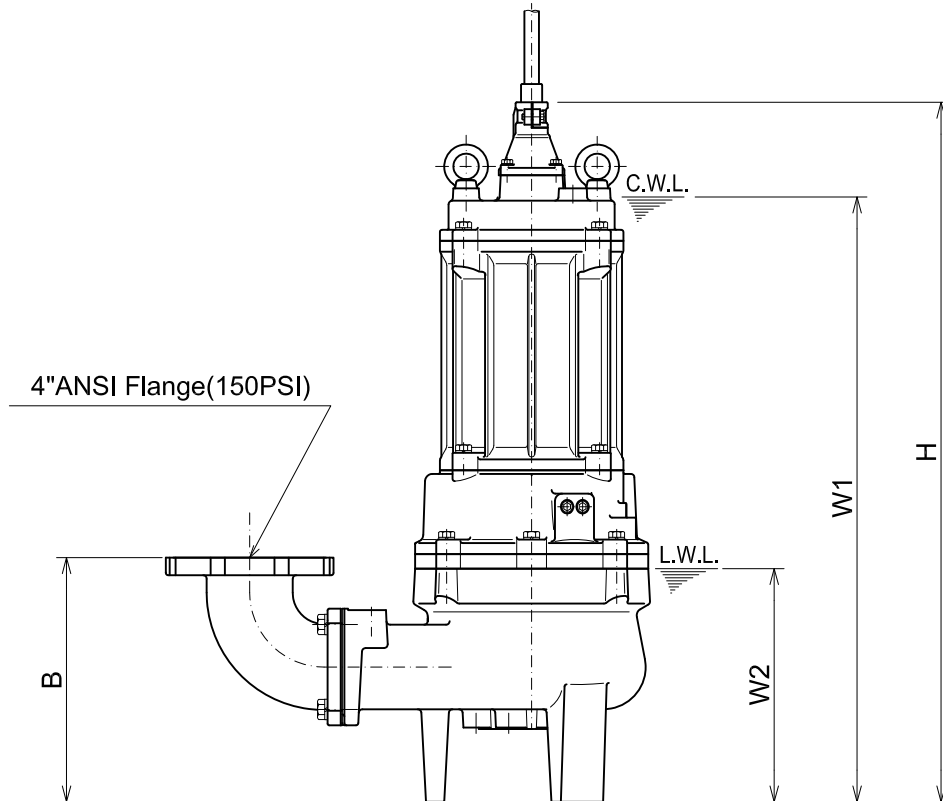

※An air release hole is provided on the top of the pump casing.

C.W.L. :Continuous running Water Level
L.W.L. :Lowest running Water Level

DIMENSIONS:USCS(Inch)

Model	HP	NOM. SIZE	Pump & Motor							C.W.L. W1	L.W.L. W2	*Wt. (lbs.)	
			A	A1	A2	B	D	D1	D2				H
100UZ45.5 -64	7.5	4"	26 7/16	15 5/16	6 5/16	13 3/16	14 1/8	7 1/16	7 1/16	36 15/16	31 7/8	12 5/8	309
100UZ47.5 -64	10	4"	26 7/16	15 5/16	6 5/16	13 3/16	14 1/8	7 1/16	7 1/16	37 13/16	32 5/8	12 5/8	340

DIMENSIONS:METRIC(mm)

Model	kW	NOM. SIZE	Pump & Motor							C.W.L. W1	L.W.L. W2	*Wt. (kg)	
			A	A1	A2	B	D	D1	D2				H
100UZ45.5 -64	5.5	100	672	397	160	335	358	179	179	939	810	320	140
100UZ47.5 -64	7.5	100	672	397	160	335	358	179	179	960	830	320	154

*Excluding Cable.



TSURUMI PUMP

UZ-SERIES
VORTEX - SEWAGE & WASTEWATER PUMPS

DIMENSIONS

TOS100UZ45.5 -64
TOS100UZ47.5 -64

Guide Rail System
 Model : TOS3-100-100 ANSI
 Wt. : 108lb. (49kg)

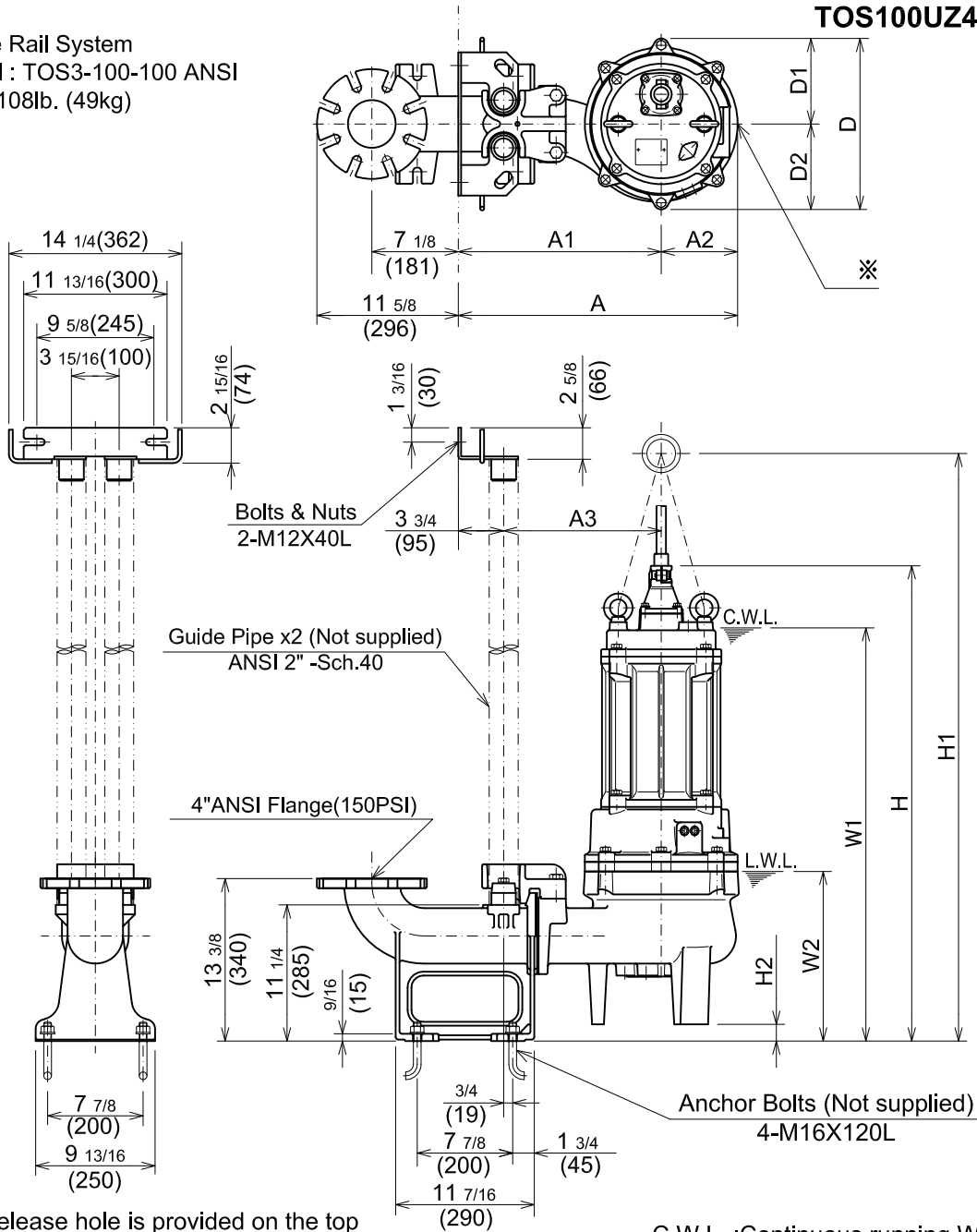

※An air release hole is provided on the top of the pump casing.

C.W.L. :Continuous running Water Level
 L.W.L. :Lowest running Water Level

DIMENSIONS:USCS(Inch)

Model	HP	NOM. SIZE	Pump & Motor									C.W.L.	L.W.L.	*Wt. (lbs.)		
			A	A1	A2	A3	D	D1	D2	H	H1				H2	W1
TOS100UZ45.5 -64	7.5	4"	23 1/16	16 3/4	6 5/16	13	14 1/8	7 1/16	7 1/16	7 1/16	38 3/8	51 3/8	1 3/8	33 1/4	14	295
TOS100UZ47.5 -64	7.5	4"	23 1/16	16 3/4	6 5/16	13	14 1/8	7 1/16	7 1/16	7 1/16	39 3/16	52 7/8	1 3/8	34	14	326

DIMENSIONS:METRIC(mm)

Model	kW	NOM. SIZE	Pump & Motor									C.W.L.	L.W.L.	*Wt. (kg)		
			A	A1	A2	A3	D	D1	D2	H	H1				H2	W1
TOS100UZ45.5 -64	5.5	100	585	425	160	330	358	179	179	179	974	1305	35	845	355	134
TOS100UZ47.5 -64	5.5	100	585	425	160	330	358	179	179	179	995	1343	35	865	355	148

*Excluding TOS & Cable.



UZ-SERIES
VORTEX - SEWAGE & WASTEWATER PUMPS

SECTIONAL VIEW

80UZ45.5 -64
80UZ47.5 -64
100UZ45.5 -64
100UZ47.5 -64

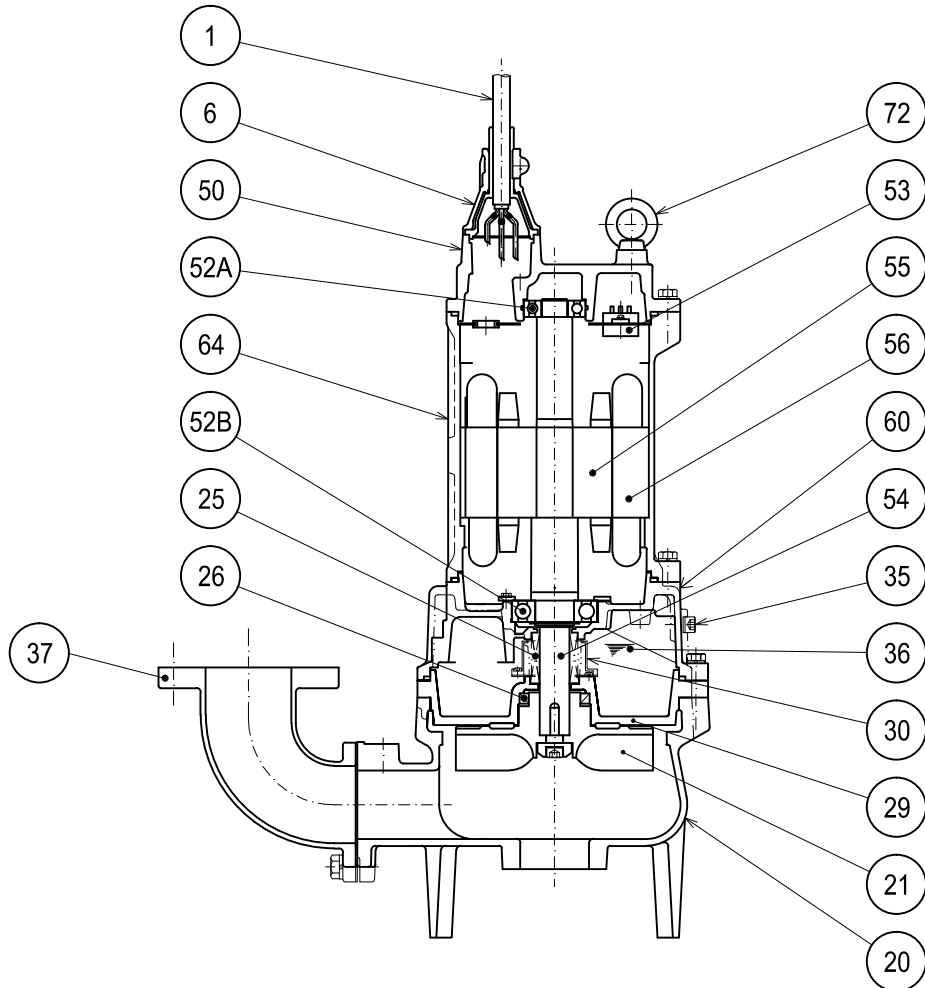

	UZ45.5	UZ47.5
* 1	AWG 12/4-32ft	AWG 10/4-32ft
* 2	AC-#6305ZZC3	AC-#6306ZZC3

PART#	DESCRIPTION	MAIN MATERIAL / NOTE	RELATED ASTM,AISI CODE	RELATED EN CODE	QTY
1	Power Cable	Chloroprene Sheath * 1			1
6	Stuffing Box	Cast Iron	A48M Class30B	EN 1561 GJL-200	1
20	Pump Casing	Cast Iron	A48M Class30B	EN 1561 GJL-200	1
21	Impeller	Cast Iron	A48M Class30B	EN 1561 GJL-200	1
25	Mechanical Seal	Silicon Carbide / H-35A			1
26	Oil Seal	NBR / TC608212			1
29	Oil Casing	Cast Iron	A48M Class30B	EN 1561 GJL-200	1
30	Oil Lifter	PBT Plastic w/(GF+MD)40			1
35	Oil Plug	Stainless Steel	S 30400	1.4301	2
36	Lubricant	Turbine Oil ISO VG32 or SAE 10W-20			
37	Discharge Bend	Cast Iron / 3" or 4" ANSI Flange(150PSI)	A48M Class30B	EN 1561 GJL-200	1
50	Motor Bracket	Cast Iron	A48M Class30B	EN 1561 GJL-200	1
52A	Upper Bearing	* 2			1
52B	Lower Bearing	#6309ZZC3			1
53	Motor Protector				1
54	Shaft	Stainless Steel	S 42000	1.4028	1
55	Rotor				1
56	Stator				1
60	Bearing Housing	Cast Iron	A48M Class30B	EN 1561 GJL-200	1
64	Motor Housing	Cast Iron	A48M Class30B	EN 1561 GJL-200	1
72	Lifting Lug Bolt	Steel	A283 Grade D	EN 10025 S275	2

TSURUMI PUMP
**UZ - SERIES
VORTEX - SEWAGE & WASTEWATER PUMPS**
**SAMPLE
SPECIFICATIONS**
1. SCOPE OF SUPPLY -

Furnish and install TSURUMI Model _____ Submersible Pump(s). Each unit shall be capable of delivering _____ GPM(_____m³/min) at _____ Feet (_____m) TDH. The pump(s) shall be designed to pump waste water, sewage or effluent containing _____ inch (_____mm) diameter solids without damage during operation. The pump(s) shall be designed so that the shaft power required (BHP)/(kW) shall not exceed the motor rated output throughout the entire operating range of the pump performance curve. The pump discharge size shall be _____inch, (_____mm).

2. MATERIALS OF CONSTRUCTION -

Construction of major parts of the pumping unit(s) including pump casing, impeller, and discharge elbow shall be manufactured from gray cast iron, ASTM A48 CLASS 35. Internal and external surfaces coming into contact with the pumpage shall be protected by a fused polymer coating. All exposed fasteners shall be stainless steel. All units shall be furnished with a discharge elbow with 150 lb. (10 kg/cm²) flat face flange and NPT companion flange. Impellers shall be of the vortex, solids handling design equipped with back pump out vanes and shall be slip fit to the shaft and key driven.

3. MECHANICAL SEAL -

All units shall be furnished with a dual inside mechanical shaft seal located completely out of the pumpage, running in a separate oil filled chamber and further protected by an exclusionary oil seal located between the bottom seal faces and the fluid being pumped. The oil chamber shall be fitted with a device that shall provide positive lubrication of top mechanical seal, (down to one third of the standard oil level). The device shall not consume any additional electrical power. Mechanical seals shall rated to preclude the incursion of water up to 42.6 PSI. (98.4 Ft.). Units shall have silicon carbide mechanical seal faces. Mechanical seal hardware shall be stainless steel.

4. MOTOR -

The pump motor(s) shall be _____Hp., _____ kW., _____V., 60 Hz., 3 Phase and shall be NEMA MG-1, Design Type B equivalent. Motor(s) shall be rated at _____ full load amps. Motor(s) shall have a 1.15 service factor and shall be rated for 20 starts per hour. Motor(s) shall be air filled, copper wound, class E or F insulated with built in thermal and over amperage protection for each winding. Motor shaft shall be 403 stainless steel and shall be supported by two permanently lubricated, high temperature ball bearings, with a B-10 life rating at best efficiency point of 60,000 hours. The bearings shall be single row, double shielded, C3, deep groove type ball bearings. Motor housing and bearing housing shall be gray cast iron, ASTM A48 CLASS 30. Motors shall be suitable variable speed applications, utilizing a properly sized variable frequency drive.

5. POWER CABLE AND CABLE ENTRANCE -

The pump power cable shall be suitable for submersible pump applications. The cable entrance shall incorporate built in strain relief, a one piece, three way mechanical compression seal with a fatigue reducing cable boot. The cable entrance assembly shall contain an anti-wicking block to eliminate water incursion into the motor due to Capillary wicking should the power cable be accidentally damaged.